

GEND

General Public Utilities • Electric Power Research Institute • U.S. Nuclear Regulatory Commission • U.S. Department of Energy

**Color Photographs
Of The Three Mile Island Unit 2
Reactor Containment Building:
Volume 1—Entries 1, 2, 4, 5, 6**

Gregory R. Eidam
J. Thomas Horan

PROPERTY OF
ANL-W Technical Library

October 1981

Prepared for the
U.S. Department of Energy
Three Mile Island Operations Office
Under DOE Contract No. DE-AC07-78ID01570

Printed in the United States of America

Available from
National Technical Information Service
U.S. Department of Commerce
5285 Port Royal Road
Springfield, VA 22161
NTIS Price Codes: Printed Copy A11
Microfiche A01

DISCLAIMER

This book was prepared as an account of work sponsored by an agency of the United States Government. Neither the United States Government nor any agency thereof, nor any of their employees, makes any warranty, express or implied, or assumes any legal liability or responsibility for the accuracy, completeness, or usefulness of any information, apparatus, product or process disclosed, or represents that its use would not infringe privately owned rights. References herein to any specific commercial product, process, or service by trade name, trademark, manufacturer, or otherwise, does not necessarily constitute or imply its endorsement, recommendation, or favoring by the United States Government or any agency thereof. The views and opinions of authors expressed herein do not necessarily state or reflect those of the United States Government or any agency thereof.

**COLOR PHOTOGRAPHS
OF THE THREE MILE ISLAND UNIT 2
REACTOR CONTAINMENT BUILDING:
VOLUME 1—ENTRIES 1, 2, 4, 5, 6**

**Gregory R. Eidam
J. Thomas Horan**

Published October 1981

**EG&G Idaho, Inc.
Idaho Falls, Idaho 83415**

**Prepared for the
U.S. Department of Energy
Three Mile Island Operations Office
Under DOE Contract No. DE-AC07-76IDO1570**

ABSTRACT

This report is a collection of the 308 color photographs taken during the first six entries into the Three Mile Island Unit 2 Reactor Containment Building (July 1980—February 1981). The

camera positions are mapped on simplified floor plans of the building and correlated by figure number with the photographs—all of which are sequenced for convenient inspection.

CONTENTS

ABSTRACT	ii
INTRODUCTION	1

FIGURES

SECTION A: CROSS SECTION, FLOOR PLANS, AND CAMERA MAPS OF THE UNIT 2 REACTOR CONTAINMENT BUILDING	3
i. Cross section of the TMI-2 Reactor Containment Building	5
ii. Floor plan of elevation 305, by quadrants	6
iii. Floor plan of elevation 347, by quadrants	7
iv. Floor plan of elevation 347, with polar crane superimposed	8
v. Elevation 305, quadrant 1	9
v-1. Map for Figures 1-8	9
v-2. Map for Figures 9-14	10
v-3. Map for Figures 15-19	11
v-4. Map for Figures 20-27	12
v-5. Map for Figures 28-43	13
vi. Elevation 305, Quadrant 2	14
vi-1. Map for Figures 44-58	14
vi-2. Map for Figures 59-65	15
vii. Elevation 305, quadrant 3	16
vii-1 Map for Figures 66-73	16
viii. Elevation 305, quadrant 4	17
viii-1 Map for Figures 74-92	17
ix. Elevation 347, quadrant 1	18
ix-1. Map for Figures 93-104	18
ix-2. Map for Figures 105-116	19
ix-3. Map for Figures 117-129	20

x.	Elevation 347, quadrant 2	21
	x-1. Map for Figures 130-142	21
	x-2. Map for Figures 143-153	22
	x-3. Map for Figures 154-162	23
	x-4. Map for Figures 153-170	24
xi.	Elevation 347, quadrant 3	25
	xi-1. Map for Figures 171-183	25
xii.	Elevation 347, quadrant 4	26
	xii-1. Map for Figures 184-200	26
xiii.	D-ring A area	27
	xiii-1. Map for Figures 201-214	27
xiv.	D-ring B area	28
	xiv-1. Map for Figures 215-220	28
xv.	Fuel pool area	29
	xv-1. Map for Figures 221-230	29
	xv-2. Map for Figures 231-245	30
	xv-3. Map for Figures 246-255	31
	xv-4. Map for Figures 256-267	32
xvi.	Crane elevations	33
	xvi-1. Map for Figures 268-276	33
	xvi-2. Map for Figures 277-289	34
	xvi-3. Map for Figures 290-308	35
SECTION B: PHOTOGRAPHS TAKEN DURING ENTRIES 1, 2, 4, 5, 6		37
Elevation 305, Quadrant 1		39
1.	Anteroom entry ramp into personnel air lock 2	41
2.	Anteroom; personnel air lock 2 at right	41
3.	Handwheel on anteroom side of air lock 2	42
4.	Technician standing within doorway of personnel air lock 2	42

5.	Technicians setting up decontamination test equipment inside of containment; air lock 2 in background, elevator door right	43
6.	Northeast view along the containment wall from the platform on the elevator shaft between elevation 305 and 347; electrical penetrations visible in background	43
7.	Gloves and coiled hose on cart just north of personnel air lock 2	44
8.	Coiled hose on north end of card; reactor building spray lines in background	44
9.	Technician removing HP-R-211 radiation monitor from northeast elevator wall	45
10.	Gai-tronic telephone and elevator door	45
11.	Surface detail of Gai-tronic phone and elevator door	46
12.	Close-up of elevator door at elevation 305	46
13.	Close-up of gap in elevator door	47
14.	Platform on the enclosed elevator-stairwell	47
15.	Door and corner of platform on the enclosed elevator-stairwell	48
16.	Inside of the elevator shaft	48
17.	Floor; covered hatch and air coolers in background	49
18.	Floor; enclosed stairway door left, air coolers background right	49
19.	Floor drain and rusted funnel	50
20.	Covered hatch; air coolers right	50
21.	Door to enclosed stairway and river water piping to air coolers	51
22.	Door to enclosed stairway, thrust open against the river water piping associated with the air coolers	51
23.	Lower portion of door to enclosed stairway	52
24.	River water piping associated with air coolers; stairwell in background left	52
25.	Bottom corner of door to enclosed stairwell, thrust against structure of river water piping	53
26.	Close view of door to enclosed stairwell and river water piping to air cooling assembly	53
27.	Surface of door to enclosed stairway	54
28.	Close-up of landing within the enclosed stairwell	54
29.	Enclosed stairs, beginning ascent from elevation 305	55
30.	Emergency lights in enclosed stairwell, view up from elevation 305	55

31.	East units of air cooling assembly	56
32.	Portion of top section of the air coolers, view from platform on enclosed stairwell	56
33.	East units of air cooling assembly; river water piping at left	57
34.	Close-up of river water piping associated with air coolers	57
35.	River water cooling pipes and valves, east end of air cooling assembly	58
36.	Upper east end of air cooling assembly	58
37.	Upper center portion of air cooling assembly	59
38.	Center units of air cooling assembly	59
39.	Floor area for decontamination test	60
40.	Floor area for decontamination test, second view	60
41.	Deposition pattern on floor; covered hatch at left	61
42.	Technician in first-entry protective clothing holding teletector; D-ring in background, corner of enclosed elevator/stairwell right edge of photograph	61
43.	Pipe on D-ring wall	62
	Elevation 305, Quadrant 2	63
44.	West units of air cooling assembly	65
45.	West upper end of air cooling assembly	65
46.	Brace and ladder at west end of air cooling assembly	66
47.	Plenum at upper west end of air cooling assembly	66
48.	Conduit runs, plenum at west end of air cooling assembly left	67
49.	From left: air coolers, personnel air lock 1 within equipment hatch, core flood tank B, D-ring wall	67
50.	Personnel air lock 1, within equipment hatch	68
51.	Door assembly of personnel air lock 1	68
52.	Handwheel on personnel air lock 1	69
53.	Power panel on I beam; open stairway in background	69
54.	Rusted welding box; Gai-tronic phone in background, open stairway at right	70
55.	Stains on floor at entrance to open stairway	70
56.	Open stairway, HP technician taking radiation surveys	71

57. Seismic instrumentation and fire service station	71
58. Broken glass on floor	72
59. Circuit box, core flood B check valve, and piping along D-ring wall	72
60. Core flood tank B piping on seismic support	73
61. Core flood tank B piping running under access platform to core flood tank valves	73
62. Check valve directly under core flood tank B	74
63. Bottom view of core flood tank B	74
64. Core flood tank inlet piping, Gai-tronic telephone, and source range instrumentation panel	75
65. Gai-tronic telephone and source range instrumentation panel	75
Elevation 305, Quadrant 3	77
66. View up open stairway	79
67. Steep-angle view down open stairway to water in basement. Note that the water level appears to be 1 to 2 inches above the lower landing	79
68. View down open stairway to water in basement. Note that the water level appears to be 1 to 2 inches above the lower landing	80
69. Northeast view through open stairway to D-ring, HP technician taking radiation survey	80
70. South view to open stairway, HP technician taking radiation survey	81
71. Northeast view taken north of open stairway; wall shielding incore instrumentation cable chase in background	81
72. Miscellaneous valves and pipes at the northwest corner of the D-ring	82
73. Closer view of valves and pipes at the northwest corner of the D-ring	82
Elevation 305, Quadrant 4	83
74. General view of flow area within quadrant 4 north of personnel airlock 2	85
75. Electrical penetrations on containment liner; R-504 top, R-505 left, R-507 center right	85
76. Electrical penetrations on containment liner	86
77. Frontside of electrical penetration R-507 on containment liner	86
78. Right frontside of electrical penetration R-507	87
79. View of electrical penetration R-507 from above	87
80. East side of D-ring wall, four vibration instrumentation panels at right	88

81. Floor penetrations 210, 211 and 211 on east side of D-ring wall	88
82. Floor penetrations 211 and 212	89
83. Gauges and instrumentation along northeast side of D-ring	89
84. Northeast side of D-ring near core flood tank A	90
85. View north from scaffolding erected at overhead piping, near core flood tank A	90
86. View up to the overhead piping, grating, and cables near core flood tank A	91
87. Mechanical penetrations R-563 and R-567 on the containment wall	91
88. Mechanical penetrations R-563 and R-567, second view	92
89. Mechanical penetrations on the containment wall; R-562, top center; R-559, R-563, and R-567	92
90. Mechanical penetrations on the containment wall; from left to right, R-555, R-559, and R-563	93
91. Mechanical penetrations R-555 and R-559 on the containment wall	93
92. Stainless steel piping and valve under core flood tank A	94
Elevation 347, Quadrant 1	95
93. Ascent up the enclosed stairway	97
94. Ascent continued up the enclosed stairway	97
95. Elevator and motor room at the top of the stairs inside the enclosed stairwell	98
96. Door to enclosed stairwell, elevation 347	98
97. General view across operating deck to enclosed stairwell; CRDM cable trays left, indexing fixture right	99
98. Close-up of hanging power cable to the auxiliary fuel handling bridge	99
99. Ventilation grill into the elevator shaft motor room	100
100. Control rod drive mechanism cable trays	100
101. General view of operating deck, enclosed stairway, ventilation fixture, and indexing fixture	101
102. General view of operating deck from atop elevator shaft	101
103. General view of operating deck from atop the elevator roof, second view	102
104. Panorama: indexing fixture left, coolant pump alignment stand and cable chase right	102
105. Operating deck from atop the elevator roof; technicians performing decontamination tests in background	103

106. South end of elevator roof, HP-R-211 dome monitor center; brackets for head lifting slings right	103
107. Enclosed stairway; head lifting slings left, air duct right	104
108. Close-up of elevator control buttons next elevator door (elevation 347)	104
109. Close-up of gap in elevator door (elevation 347)	105
110. Fifty-five gallon drum; northeast elevator wall right, containment liner background	105
111. Fifty-five gallon drum	106
112. Northeast end of enclosed stairwell, electrical breaker box mounted on elevator wall	106
113. Fifty-five gallon drum; northeast elevator wall in background	107
114. General view of floor north of the enclosed stairwell; video camera on cart, fifty-five gallon drum, and elevator door in background	107
115. Fifty-five gallon drum; corner of elevator wall left, D-ring wall background. Patches of paint lie on the floor	108
116. South end of D-ring; head lifting pendants right	108
117. West corner of enclosed stairway; head lifting pendants left, temperature instrument center ...	109
118. Operating deck from atop D-ring A, technicians performing decontamination tests	109
119. Area between south wall of enclosed stairway and air duct	110
120. Crane power cable and insulation lying over tool box south of enclosed stairwell	110
121. Tool box and drums between enclosed stairwell and air duct	111
122. Fifty-five gallon drums between enclosed stairwell and air duct	111
123. Lifting sling lying on floor south of enclosed stairwell	112
124. Fifty-five gallon drums; air duct and enclosed stairwell left, containment liner right	112
125. Radiation surveying southwest of enclosed stairway	113
126. Stainless steel specimen capsule storage stand	113
127. Wood blocks; liner left, technician right	114
128. Auxiliary fuel handling bridge area	114
129. Control rod drive mechanism cable trays	115
Elevation 347, Quadrant 2	117
130. Scaffolding around top of head lifting rig (plastic covered); internals indexing fixture left, telephone bench background	119

131. Scaffolding	119
132. Close-ups of boards on scaffolding	120
133. South liner wall: telephone bench, internals handling extension on floor, storage stand behind, internals indexing fixture right	120
134. Close-up of internals handling extension	121
135. Telephone bench, due south against liner	121
136. Bell Telephone	122
137. Closer view of Bell Telephone	122
138. Close-up of Bell Telephone	123
139. Close-up of Bell Telephone, second view	123
140. Storage stands for the mirror insulation	124
141. Decontamination test area in front of mirror insulation storage stands	124
142. Close-up of decontamination test	125
143. Close-up of the storage stand for the mirror insulation	125
144. Panorama west from the enclosed stairwell; indexing fixture left, internals handling pendants in their storage stands and reactor coolant pump with vessel head and internals center	126
145. Reactor coolant pump alignment stand and internals handling pendants	126
146. Base of reactor coolant pump alignment stand	127
147. HP technicians preparing to take an area swipe; air duct left, reactor coolant pump stand right	127
148. Close-up of the seal plate, in two pieces	128
149. Top of reactor coolant pump motor stand	128
150. Storage stand for the reactor vessel studs	129
151. Reactor vessel guide studs	129
152. Close-up of reactor vessel guide studs and melted rod rope	130
153. A top portion of the reactor vessel stud storage stand	130
154. Internals lifting pendant	131
155. Reactor coolant pump alignment stand; coolant pump motor stand right	131
156. Reactor vessel head storage stand	132

157. View inside of the head storage stand, looking west (tops of vessel guide studs appearing above rim); stainless steel spray line left	132
158. Northeast view inside of the head storage stand at stainless steel spray line used to decontaminate the reactor head	133
159. Section of the stainless steel spray line inside of the head storage stand	133
160. Close-up of the reactor vessel head storage stand; open stairway in background	134
161. Open stairway	134
162. Crosswalk leading from top of open stairway to the east D-ring	135
163. Southwest side of D-ring	135
164. Corner of west D-ring, view opening on auxiliary fuel handling bridge	136
165. Auxiliary fuel handling bridge from southwest	136
166. Panorama across the operating deck; pump stand right, enclosed stairwell background	137
167. Southeast across the operating deck toward the enclosed stairwell; technicians are working with video camera	137
168. Floor grating over core flood tank B; D-ring wall and auxiliary fuel handling bridge background	138
169. Polar crane power cable and insulation on grating over core flood tank B	138
170. Extension pendant hanging from the handling fixture atop the pump stand	139
Elevation 347, Quadrant 3	141
171. Area just north of the open stairway	143
172. Incore instrumentation electrical connections (first view); steel structure on fuel handling bridge background right	143
173. Incore instrumentation electrical connections (second view); steel structure on fuel handling bridge background right	144
174. Incore instrumentation electrical connections; main fuel handling bridge background	144
175. Penetration 626, with video camera and telemeter dosimetry antennas	145
176. Incore instrumentation electrical connections, main fuel handling bridge background, closer view	145
177. Incore instrumentation seal table	146
178. Incore instrumentation seal table, closer view and taken from behind metal box	146
179. Incore seal table, view from above	147

180. West side of the incore seal table	147
181. A northeast portion of the incore seal table	148
182. North end of the fuel pool; incore seal table background, main fuel handling bridge left	148
183. View of valve for supply water to the fuel pool	149
Elevation 347, Quadrant 4	151
184. East side of containment from atop the elevator	153
185. East side of D-ring B wall; air tank right center, HP technician recording survey left	153
186. Coil of electrical cord on work bench	154
187. East side of D-ring B, showing air tank and gauges	154
188. Air pressure regulator mounted on the D-ring wall and a guage on which the lens has melted	155
189. Plastic wrapped equipment lying on floor near liner north of enclosed stairwell	155
190. Floor penetration 266, along east side of D-ring wall	156
191. Tool cabinet and boxes; purge ducting and guages for steam generator side left, cable trays background	156
192. Purge ducting and tool boxes	157
193. Gauges for steam generator secondary side; tool box foreground	157
194. Decking over core flood tank A; cable trays background	158
195. View down the seismic gap near the hatch over core flood tank A	158
196. Charred radiation sign lying on the decking over core flood tank A	159
197. Technician preparing to perform decontamination tests	159
198. Energized electrical outlets	160
199. Energized electrical outlets and cable trays	160
200. Charred manual lying on top of electrical box	161
D-ring A area	163
201. Top of D-ring A, and missile shields over the reactor vessel	165
202. Pressurizer from top of D-ring A; reactor coolant pump right	165
203. Pressurizer, first view from northwest	166

204. Pressurizer, second view from northwest	166
205. Pressurizer, third view from northwest	167
206. Pressurizer, fourth view from northwest	167
207. Pipes leading to the pressurizer	168
208. Valves and pipes above pressurizer.	168
209. Valves and pipes associated with pressurizer	169
210. Pressure-operated release valve above the pressurizer	169
211. Inside D-ring A near the pressurizer	170
212. Top of steam generator A from northwest	170
213. Close-up of the top of steam generator A	171
214. Steam generator and reactor coolant pump, view from atop D-ring	171
D-ring B area	173
215. Top south portion of D-ring A and auxiliary fuel handling bridge from atop the elevator roof	175
216. Top of east (A) D-ring from atop the elevator roof	175
217. Closer view of top of D-ring A from atop the elevator roof	176
218. Cabinet mounted on outside railing above east side of D-ring	176
219. Reactor coolant pump inside D-ring B	177
220. View down into D-ring B showing seismic support for equipment	177
Fuel Pool Area	179
221. Auxiliary fuel handling bridge	181
222. Power track and bridge motor of auxiliary fuel handling bridge	181
223. Power track and bridge motor of auxiliary fuel handling bridge, view from southeast, with HP technicians	182
224. Rusted coupling and motor on auxiliary fuel handling bridge	182
225. Reactor vessel and auxiliary fuel handling bridge from atop west D-ring; HP technician taking survey behind neutron shield tank	183
226. Lower east end of auxiliary fuel handling bridge	183
227. South end of the fuel pool; the 2 x 3 array fuel storage rack left, the internals storage stand right	184

228. Power track and rail of auxiliary fuel handling bridge and top of ladder down into refueling pool	184
229. Power track and rail of auxiliary fuel handling bridge and top of ladder down into refueling pool, second view	185
230. Close-up of rails for auxiliary fuel handling bridge and top of ladder down into refueling pool	185
231. Operator's panel on the auxiliary fuel handling bridge	186
232. Auxiliary fuel handling bridge, view from northwest	186
233. Charred operator's manual lying at the base of the auxiliary fuel handling bridge control panel	187
234. Operator's panel on the auxiliary fuel handling bridge, second or closer view	187
235. Lower portion of the control panel on the auxiliary fuel handling bridge	188
236. Close-up of the control panel on the auxiliary fuel handling bridge, first view	188
237. Close-up of the control panel on the auxiliary fuel handling bridge, second view	189
238. Close-up of the control panel on the auxiliary fuel handling bridge, third view	189
239. Close-up of the control panel on the auxiliary fuel handling bridge, fourth view	190
240. Top of the control rod drive mechanism (CRDM) platform above the reactor vessel; auxiliary fueling handling bridge foreground, main fuel handling bridge background right, first view	190
241. Control rod drive mechanism (CRDM) platform and power cables; main fuel handling bridge background, second view	191
242. CRDM platform and incoming power cables, third view	191
243. CRDM platform and incoming power cables, fourth view	192
244. CRDM platform and incoming power cables, fifth view	192
245. Top of the CRDM and upper portion of the service platform	193
246. Top of the CRDM and service platform, view from above	193
247. CRDM cable trays along D-ring B; walkway above, access ladder left	194
248. Close-ups of the CRDM platform above the reactor vessel	194
249. Close-up of the CRDM platform from overhead	195
250. View south along CRDM cable trays; CRDM cables protruding in background	195
251. Close view of CRDM cable trays; hand rail to auxiliary fuel handling bridge right	196

252. North end of fuel pool; main fuel handling bridge left, up ender and internals storage stand left center in deep portion of the pool	196
253. The reactor head from above	197
254. Fan housings on the reactor head	197
255. Base of the reactor vessel with neutron shield tanks	198
256. View inside of neutron shield tank	198
257. View underneath a neutron shield tank	199
258. Second view underneath a neutron shield tank	199
259. Close-up view under a neutron shield tank	200
260. Reactor vessel head	200
261. Close-up of a portion of a neutron shield tank	201
262. Reactor vessel head; fuel handling girder above	201
263. Deep (north) end of the fuel pool; main fuel handling bridge left, fuel transfer tube left center	202
264. Deep (north) end of the fuel pool, second view	202
265. View down southeast into the fuel pool; reactor vessel, neutron shield tanks, and boots of HP technician background	203
266. Motor, gear box, and drive shaft on south side of main fuel handling bridge	203
267. Upper portion of the main fuel handling bridge	204
Crane Elevations	205
268. Access platform to the polar crane; containment spray lines left	207
269. Close-up of the access platform to the polar crane	207
270. East side of polar crane near access platform	208
271. Ventilation duct on the containment wall, southwest quadrant	208
272. End of the polar crane opposite the operator's cab, northwest quadrant	209
273. End of the polar crane opposite the operator's cab, northwest quadrant, second view	209
274. Trolley and one of its wheels	210
275. Polar crane cab and upper portion of ventilation duct left	210
276. Top of ventilation duct near the enclosed stairwell	211

277. Polar crane cab	211
278. Polar crane power buss bars	212
279. Closer view of the power buss bars	212
280. Close-up of power and controller buss bars for the polar crane	213
281. Control levers of the polar crane cab	213
282. Control levers of the polar crane cab, second view	214
283. Close-up of levers of the polar crane cab	214
284. Lights around dome of the containment building; polar crane cab left	215
285. Top of the ventilation duct; job crane right	215
286. Jib crane and support box, southwest quadrant	216
287. Jib crane; D-ring A lower right	216
288. Jib crane control pendant, and lifting hook	217
289. Girder A of the polar crane	217
290. Girder B of the polar crane, with hook and cables	218
291. Auxiliary hook of the polar crane	218
292. Main hook of the polar crane	219
293. Main hook of the polar crane, second view	219
294. Main hook of the polar crane, third view	220
295. Main hook of the polar crane, fourth view	220
296. Main hook of the polar crane, fifth view	221
297. Cable drum and the main block of the trolley on the polar crane	221
298. Cable drum and the main block of the trolley on the polar crane second view	222
299. Cable drum on right side of the trolley over girder B	222
300. Close-up of cables for the main hook	223
301. Gear housings and drive shafts on the trolley of the polar crane	223
302. Containment dome north of the enclosed stairwell	224
303. Trolley power and controller buss bars along side of girder B	224
304. Trolley power and controller buss bars along side of girder B, second view	225

305. Trolley power and controller buss bars along side of girder B, third view 225

306. Trolley power and controller buss bars, view from the midpoint of the polar crane access ladder 226

307. Northwest portion of girder B, showing trolley power and controller buss bars 226

308. View northwest across containment down the length of girder B of the polar crane 227

INTRODUCTION

This is a collection of all photographs taken during the first six entries into the Three Mile Island Unit 2 Reactor Containment Building (23 July 1980, 15 August 1980, 16 October 1980, 13 November 1980, 11 December 1980, 3 February 1981, and 5 February 1981) excluding only those photographs that were grossly out of focus or very badly exposed. Due to operator error and the consequent malfunction or maladjustment of both cameras, no photographs were acquired during entry 3. The collection totals 308 photographs, as indicated:

Entry	Camera A	Camera B	Camera C
1	29	—	—
2	33	34	—
3	0	0	—
4	36	35	—
5	20	37	33
6	36	—	—

The photographs are presented in six groups:

1. Elevation 305—where all photographs are taken from the floor level unless otherwise noted
2. Elevation 347—which includes photographs taken during the ascent within the enclosed stairwell; photographs taken from the floor level, and photographs taken from the roof of the elevator and top of the D-ring walls or walkways to subjects across or below
3. D-ring A—which includes all subjects within D-ring A
4. D-ring B—which includes all subjects within D-ring B
5. Fuel Pool Area—which includes all subjects within the fuel pool area, that is, between the D-rings
6. Crane Elevation—which includes all photographs taken of the crane assembly and related subjects at high elevations.

Further, the photographs on elevations 305 and 347 are divided into quadrants. Photographs are sequenced within the first quadrant (both elevations) showing first the entry area, then left of entry to quadrant edge, then right of entry, progressing around the perimeter, and coming back to the entry along the D-ring. Within the second

quadrant, photographs progress around the perimeter and back along the D-ring. Within the third and fourth quadrants, the photographs progress from south to north outside the D-ring. The photographs of subjects within the D-rings and the reactor pool area are from south to north. The pool area forms a natural photograph group that avoids the difficulty of placing the borderline subjects within one quadrant or another. The final group, or crane elevation photographs, are grouped by general subject across the dome of the building with little respect to quadrants.

Correlation of the photographs to the containment building is further, and more especially, provided by Figures i through xvi. Figure i is a simplified cross section of the reactor containment building indicating general vertical placement of major features, including floor elevations 305 and 347. Figures ii and iii are simplified floor plans of the two floor elevations, sectioned into quadrants. Figure iv is a sketch of the polar crane overlaid on elevation 347 to represent the higher or dome elevations. Figures v through xvi are these quadrant floors sections enlarged and the dome sketch, which map—in approximate fashion—the camera positions for each photograph and indicate the subject area shown in each photograph. Each map area number corresponds to a photograph figure number. These maps, thus, serve as an alternate table of contents, locating every photograph within the building by floor elevation, quadrant, and approximate camera position.

Each photograph has been given a figure number and is further identified by entry and camera as part of the figure designation. For example, the photograph of entry personnel standing in front of the entry hatch and elevator is placed in the collection as Figure 5(1A), indicating that the photograph was taken by camera A during entry 1 and is placed fifth in the photograph collection.

Through Entry 6, 308 photographs were taken. Subsequent entries will result in the acquisition of additional photographs, and as work progresses within the reactor building, cleanup activities will be graphically documented.^a This collection of photographs, however, provides a comprehensive record of conditions within containment at Three Mile Island Unit 2.

a. At the time of publication of this report, entries have been made and a total of photographs have been taken.

FIGURES

Section A: Cross Section Floor Plans, and Camera Maps of the TMI-2 Reactor Containment Building

Top of dome El 473 ft

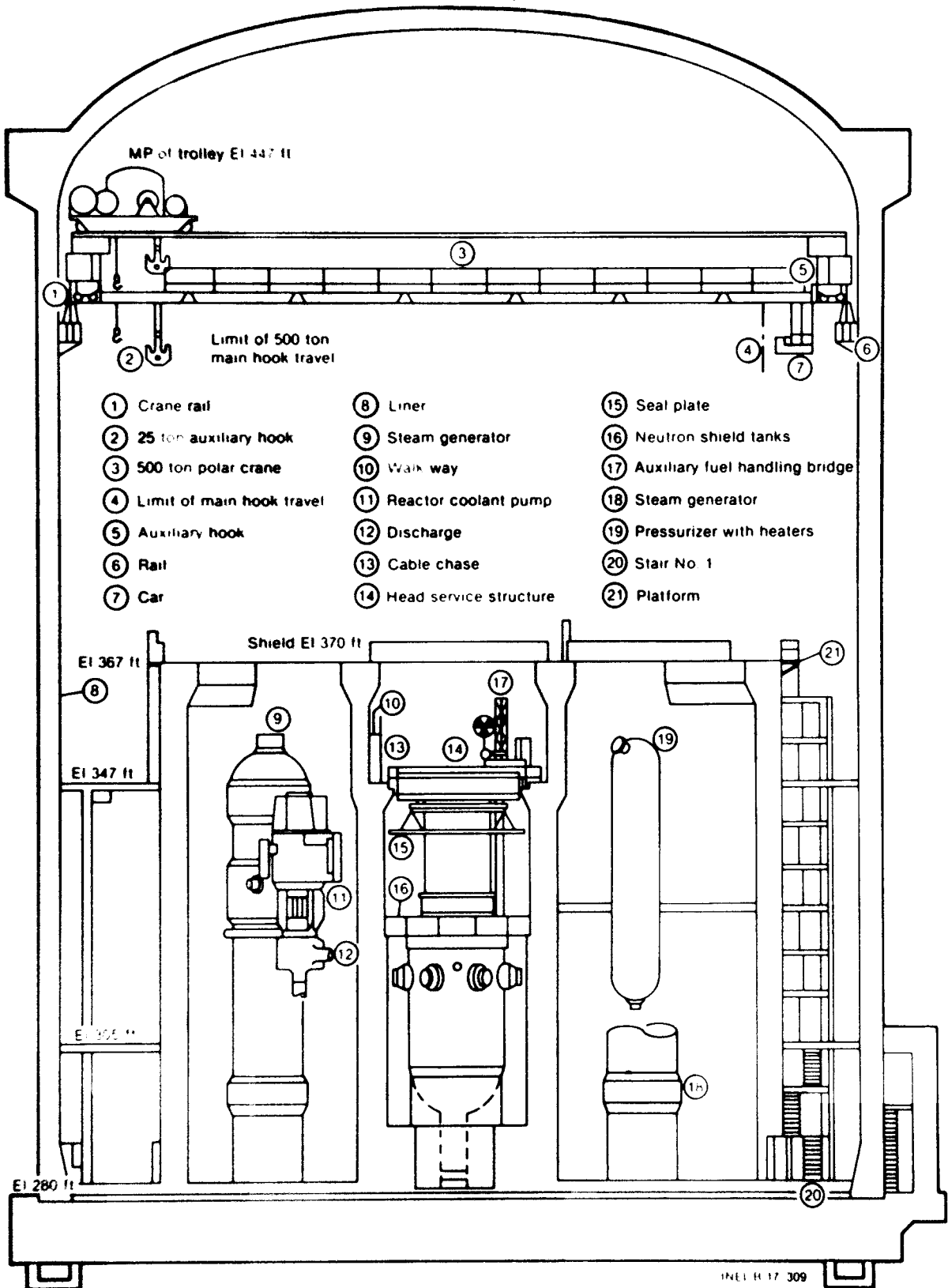

Figure 1. Cross section of the TMI-2 Reactor Containment Building.

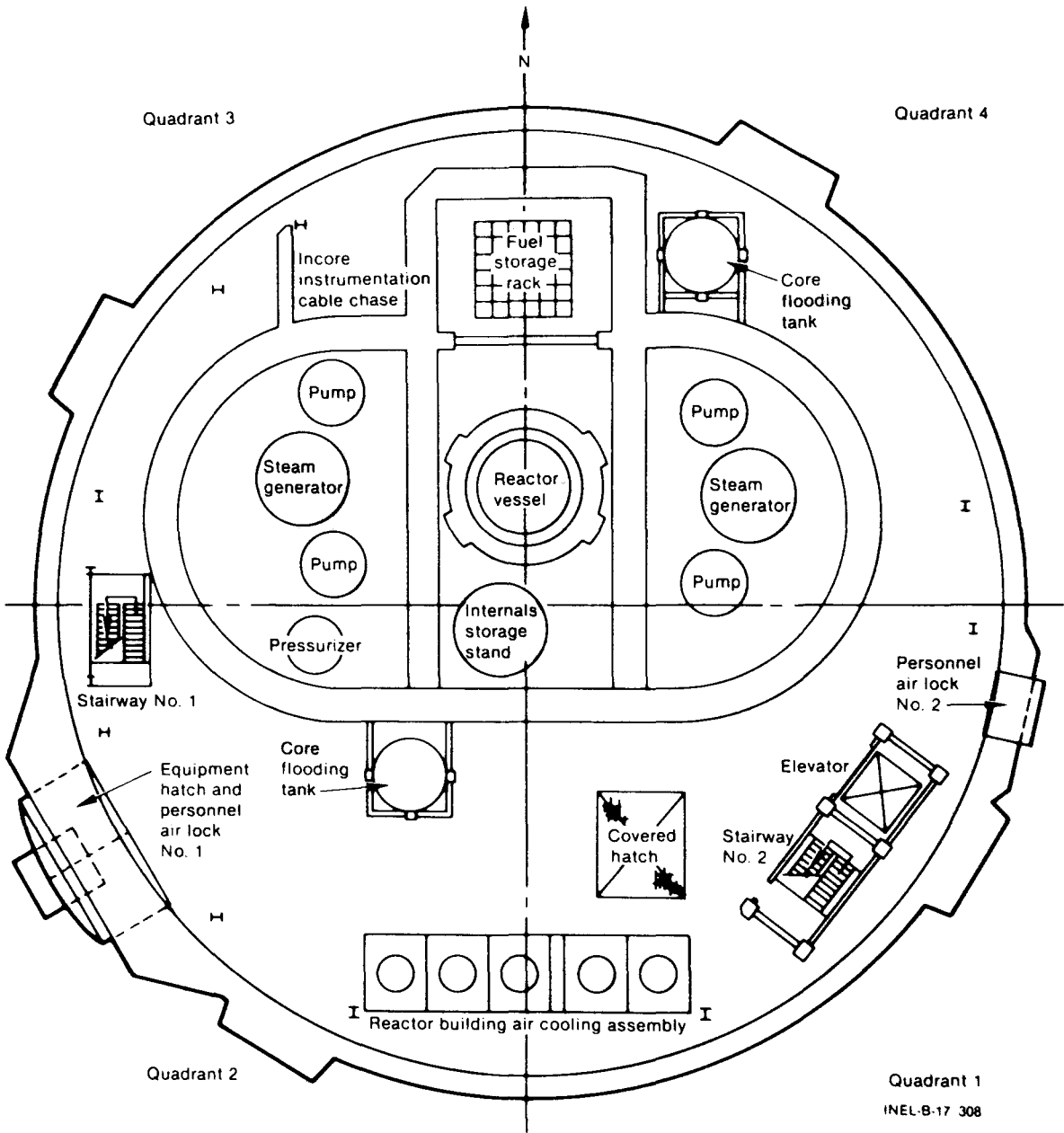

Figure ii. Floor plan of elevation 305, by quadrants.

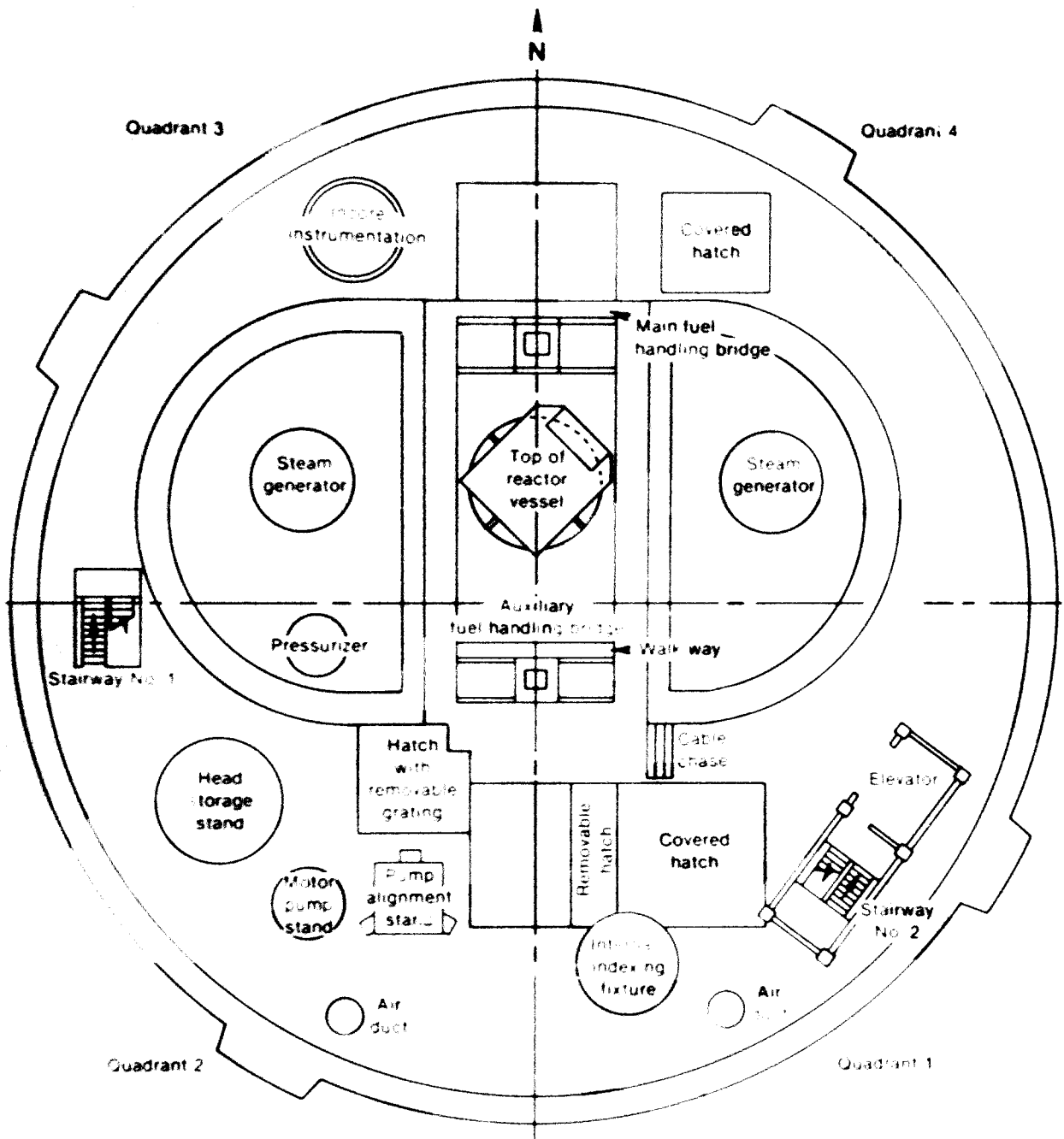

Figure iii. Floor plan of elevation 347, by quadrants.

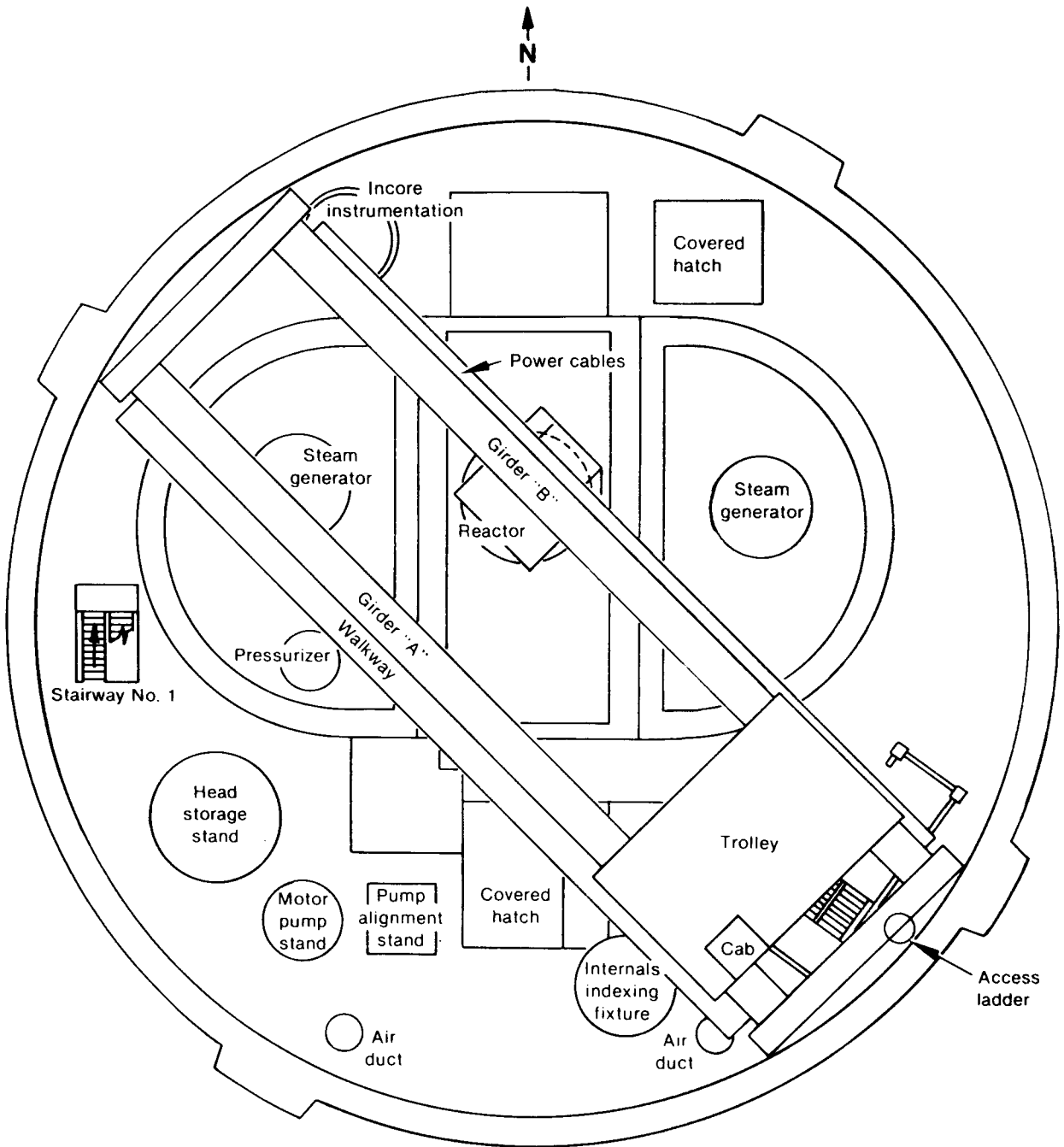
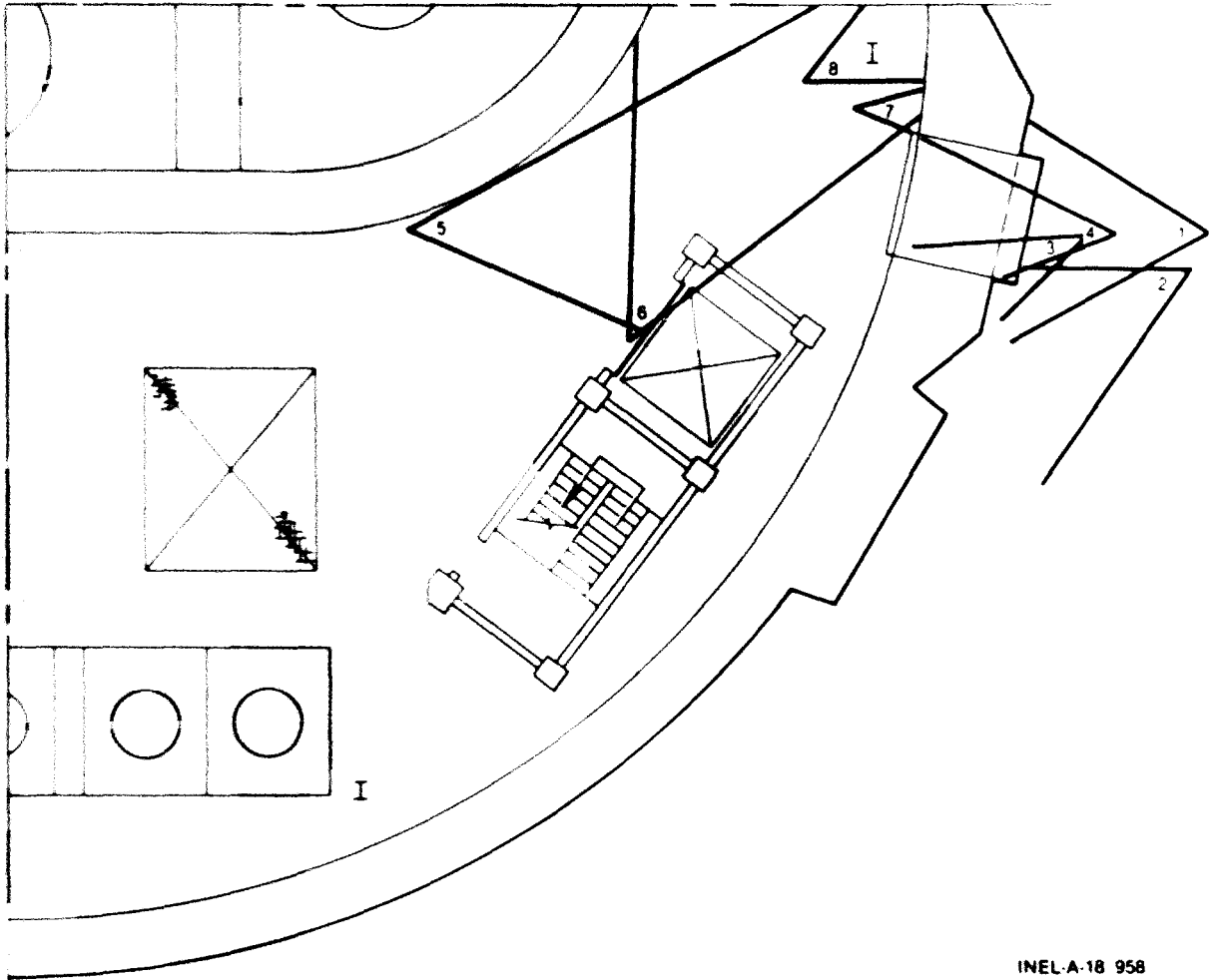

Figure iv. Floor plan of elevation 347, with polar crane superimposed.

Elevation 305, Quadrant 1



INEL-A-18 958

Figure v-1. Map for Figures 1-8.

Elevation 305, Quadrant 1

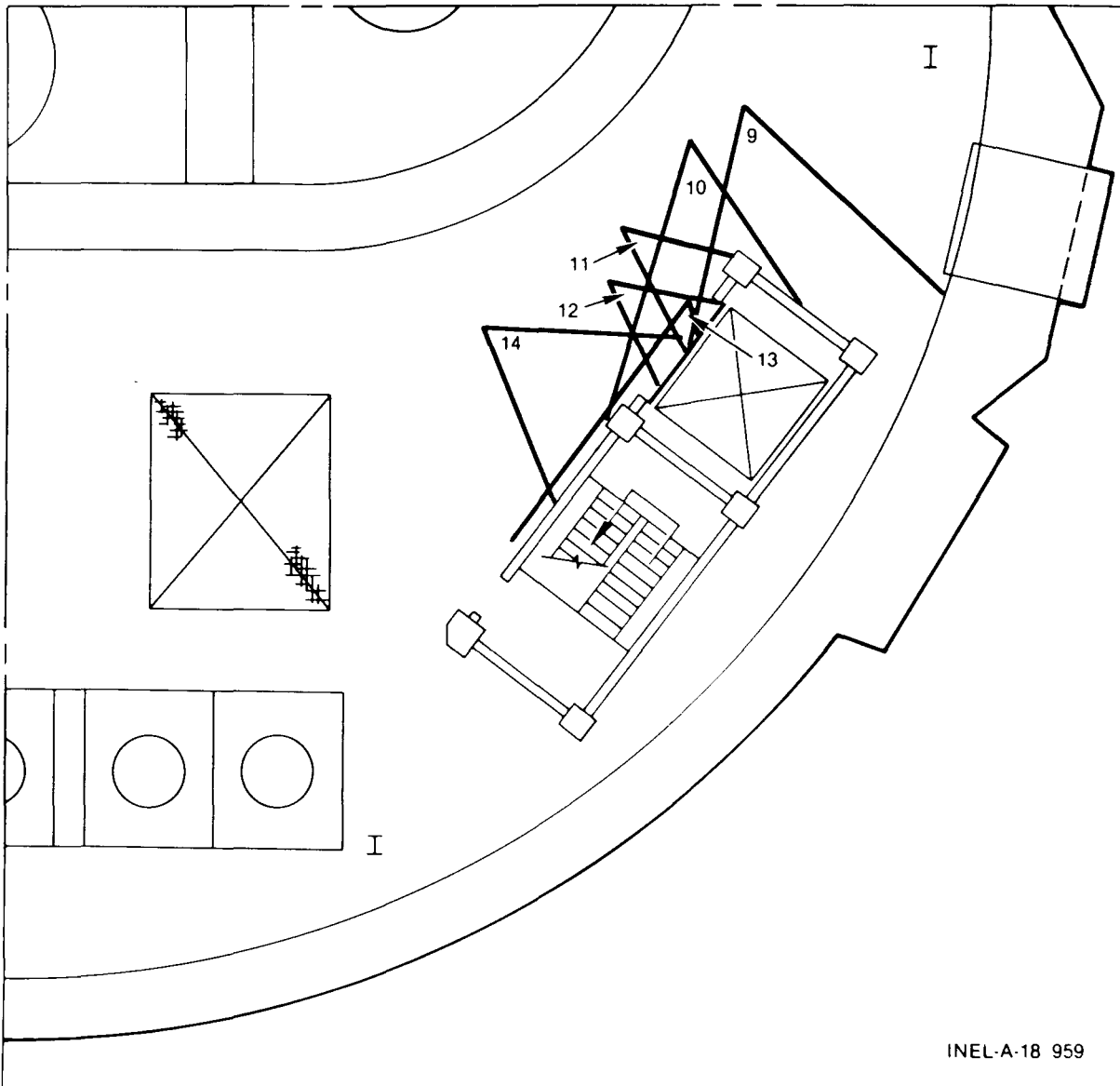

INEL-A-18 959

Figure v-2. Map for Figures 9-14.

Elevation 305, Quadrant 1

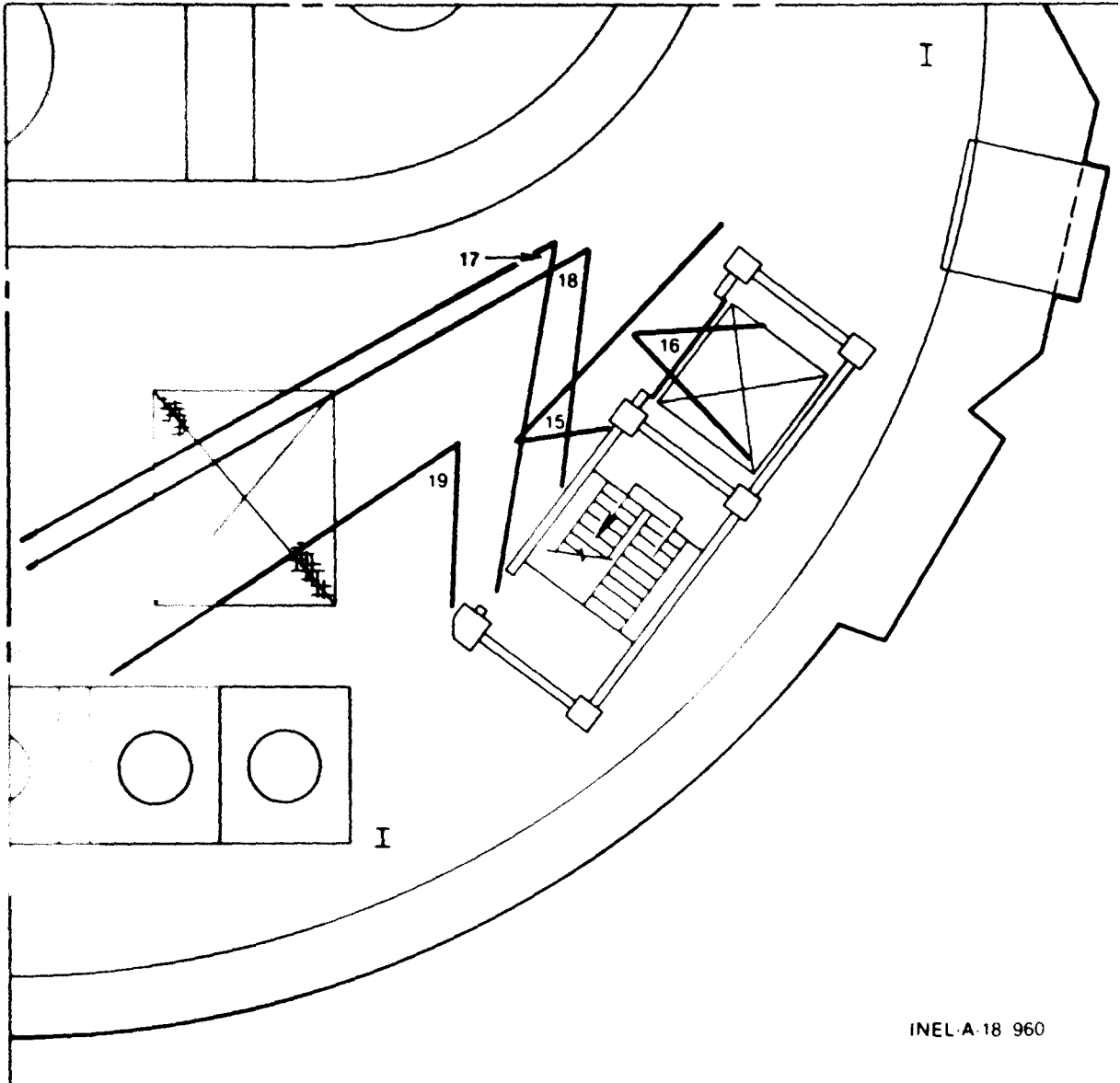

INEL-A-18 960

Figure V-3. Map for Figures 15-19.

Elevation 305, Quadrant 1

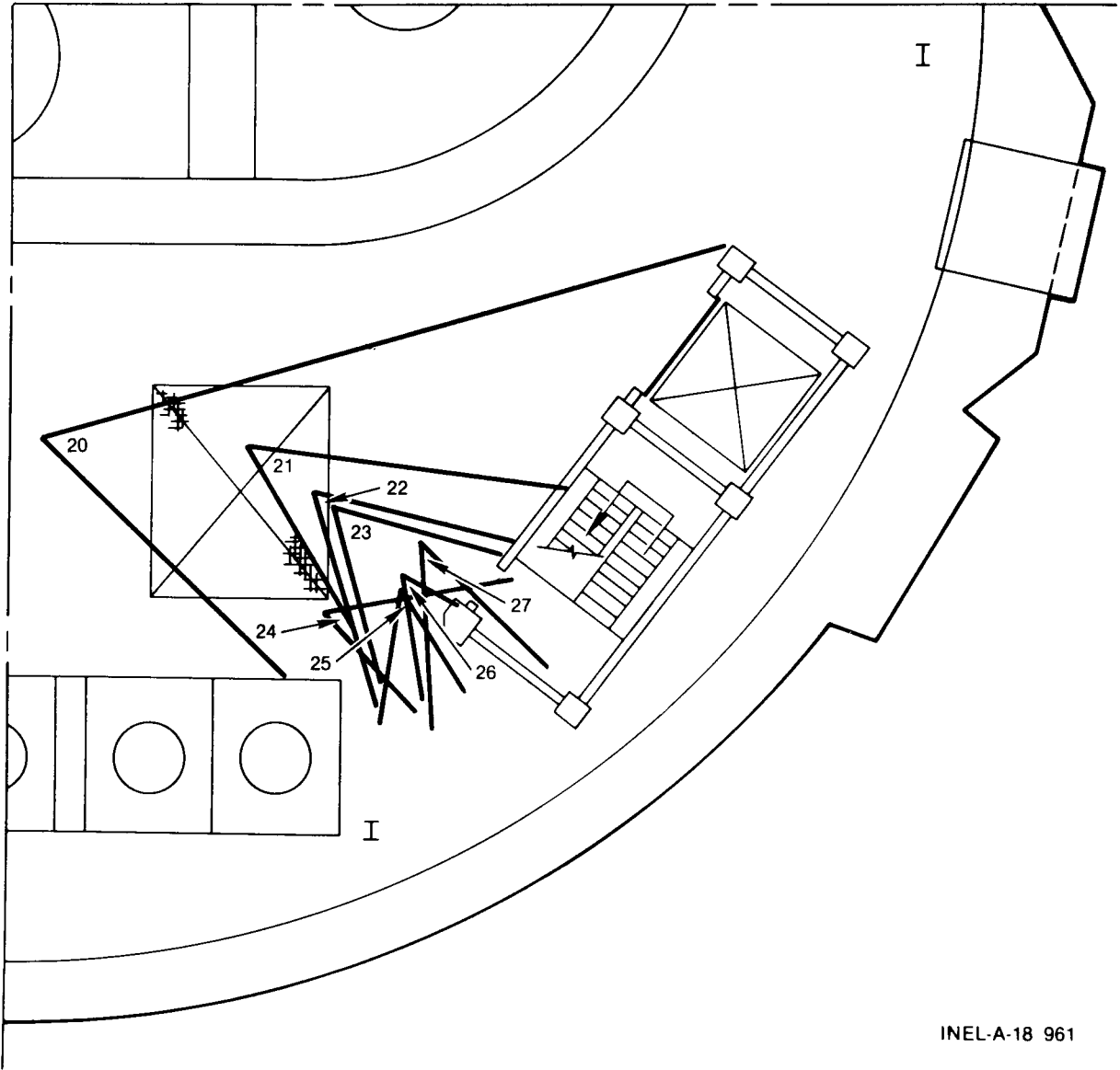

INEL-A-18 961

Figure v-4. Map for Figures 20-27.

Elevation 305, Quadrant 1

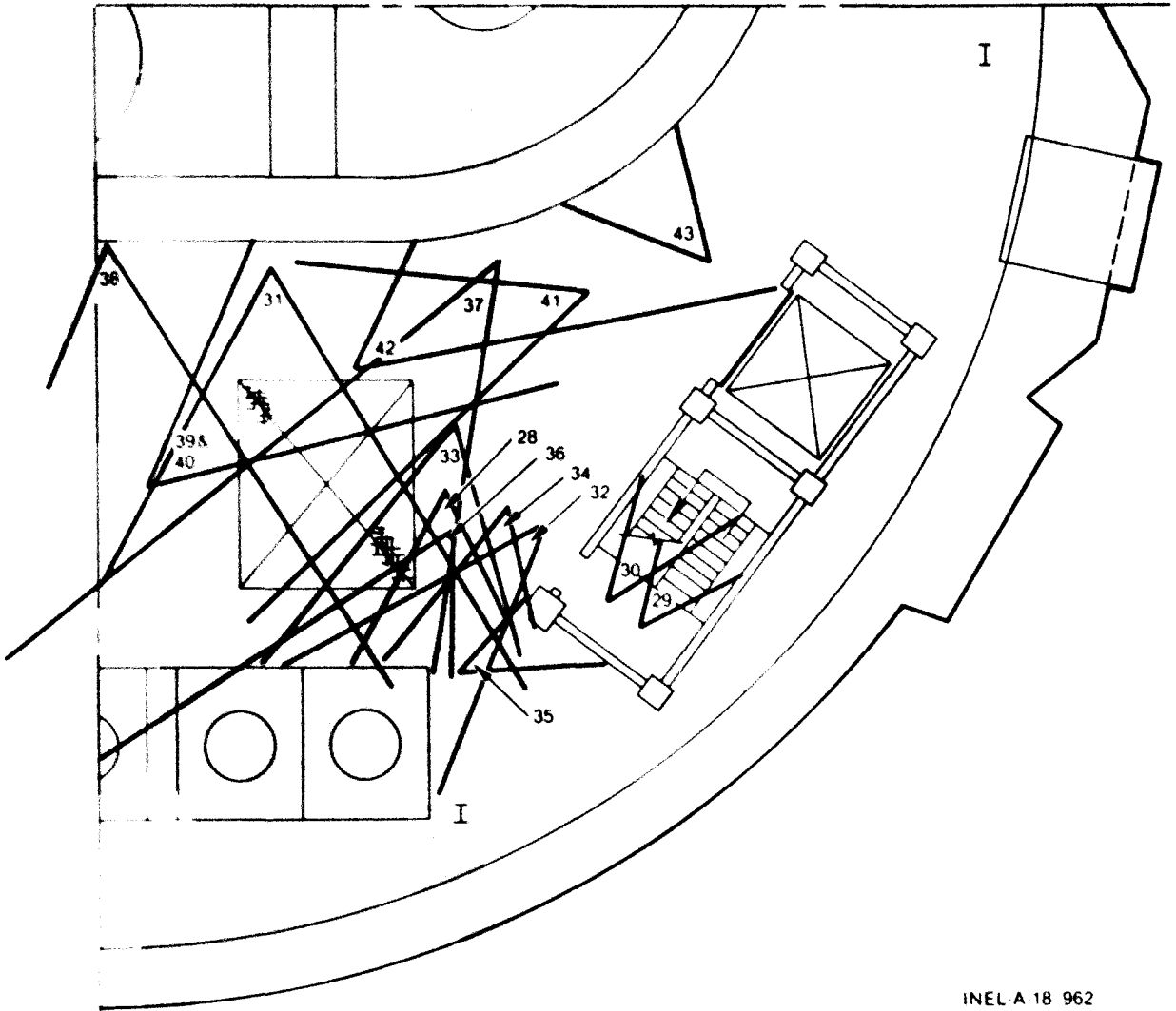

INEL A-18 962

Figure v-5. Map for Figures 28-43

Elevation 305, Quadrant 2

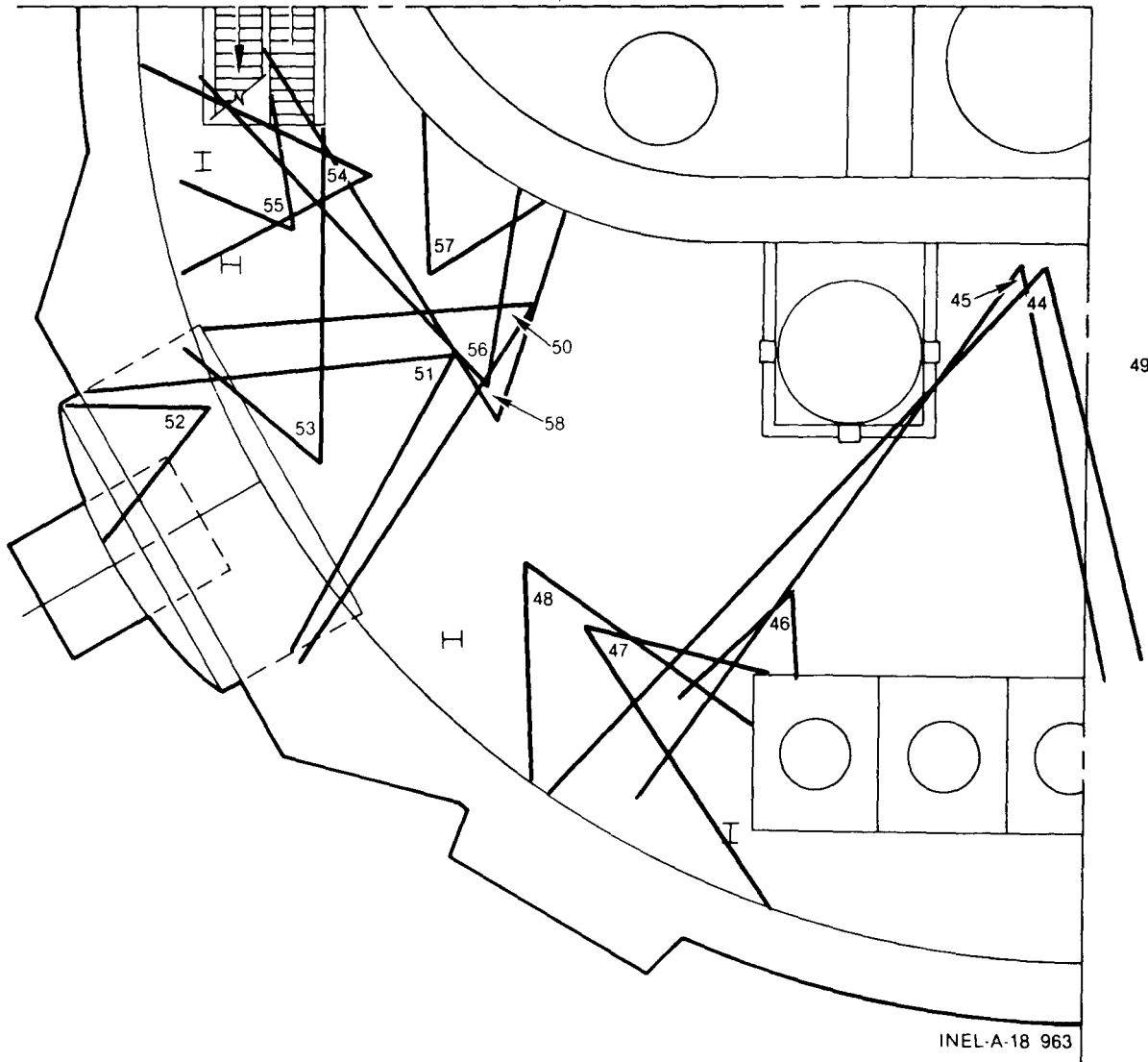
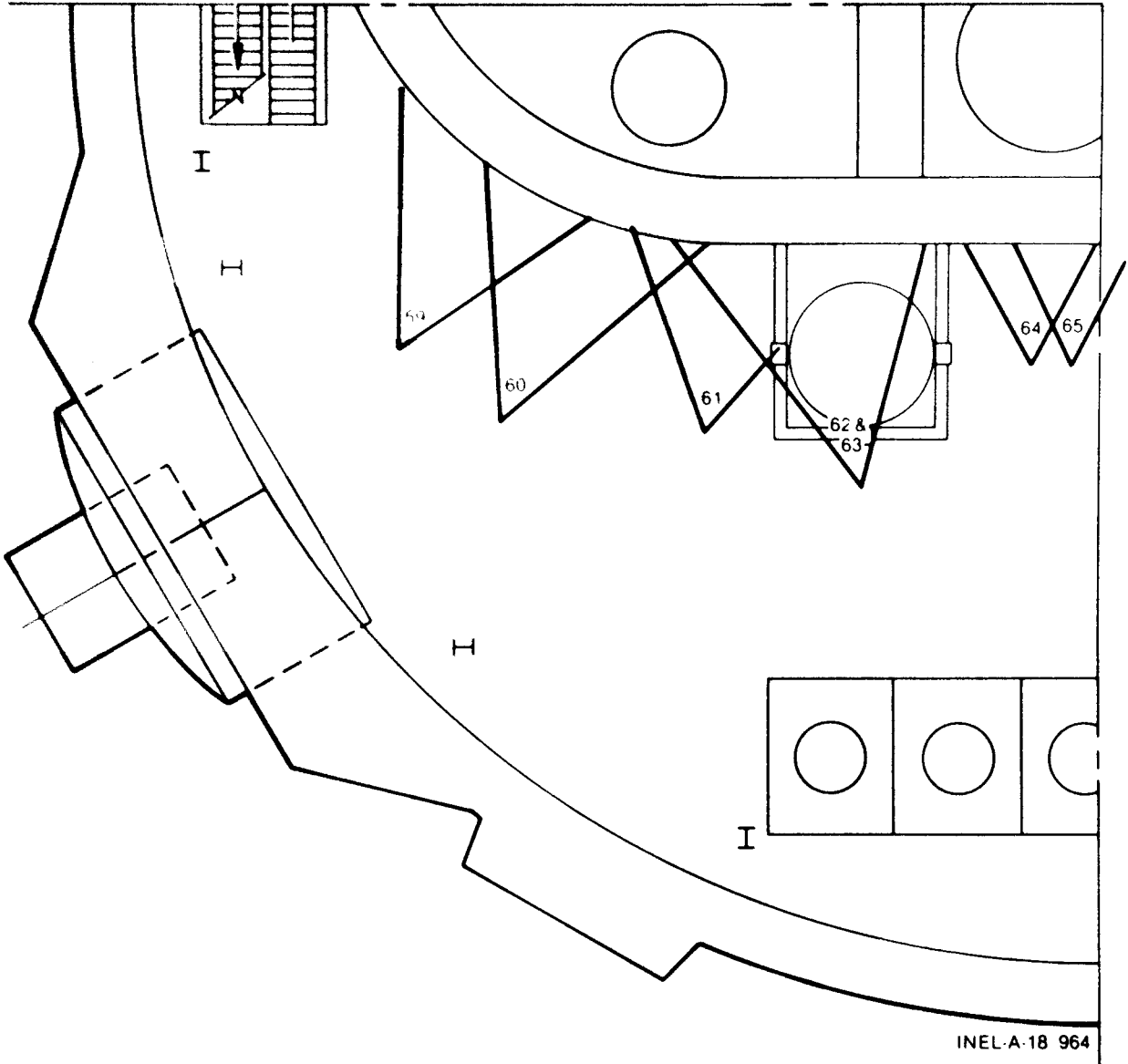

Figure vi-1. Map for Figures 44-58.

Elevation 305, Quadrant 2



INEL-A-18 964

Figure VI-2. Map for Figures 59-65.

Elevation 305, Quadrant 3

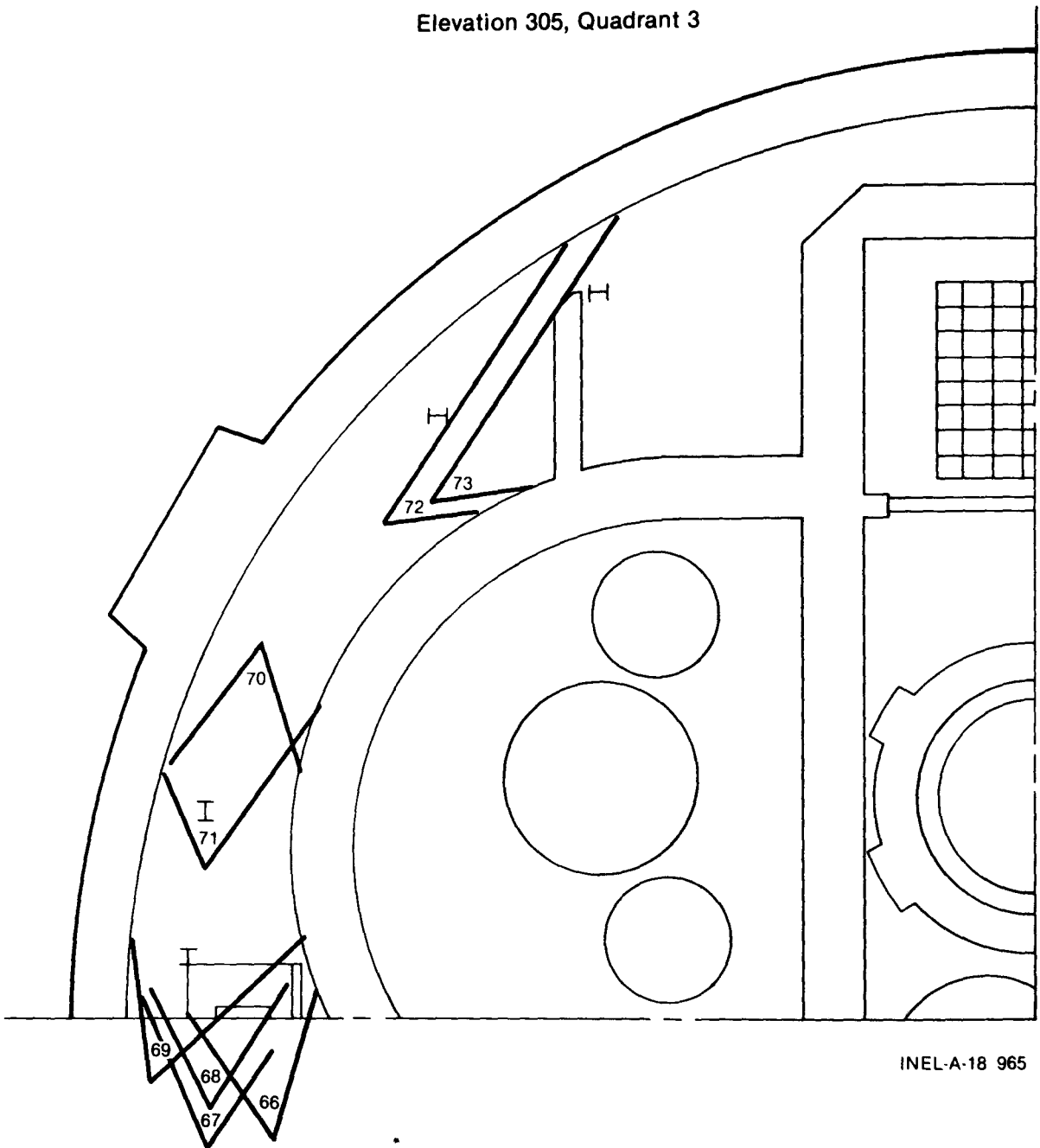

INEL-A-18 965

Figure vii-1. Map for Figures 66-73.

Elevation 305, Quadrant 4

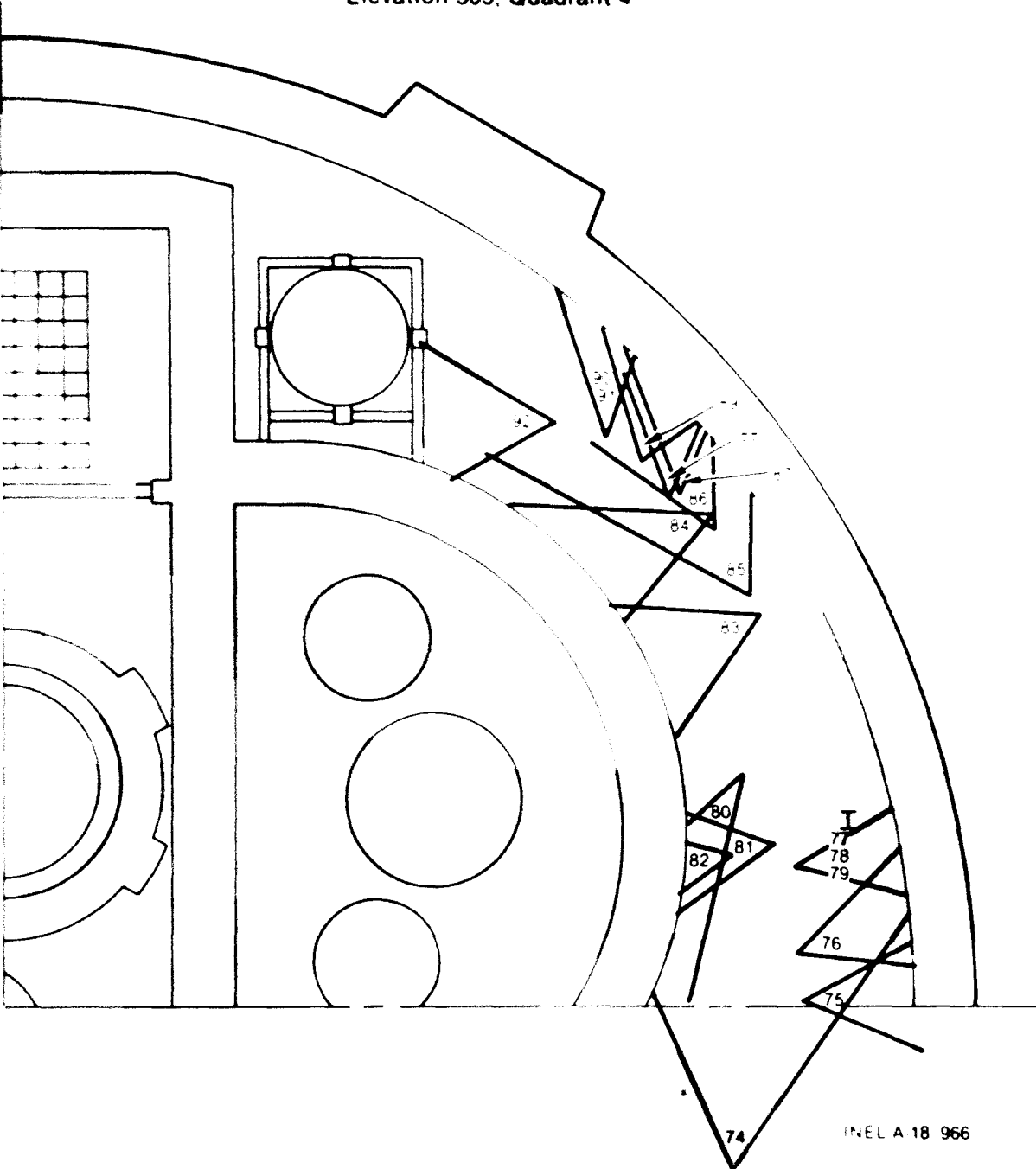

INEL A 18 966

Figure viii-1. Map for Figures 74-92.

Elevation 347, Quadrant 1

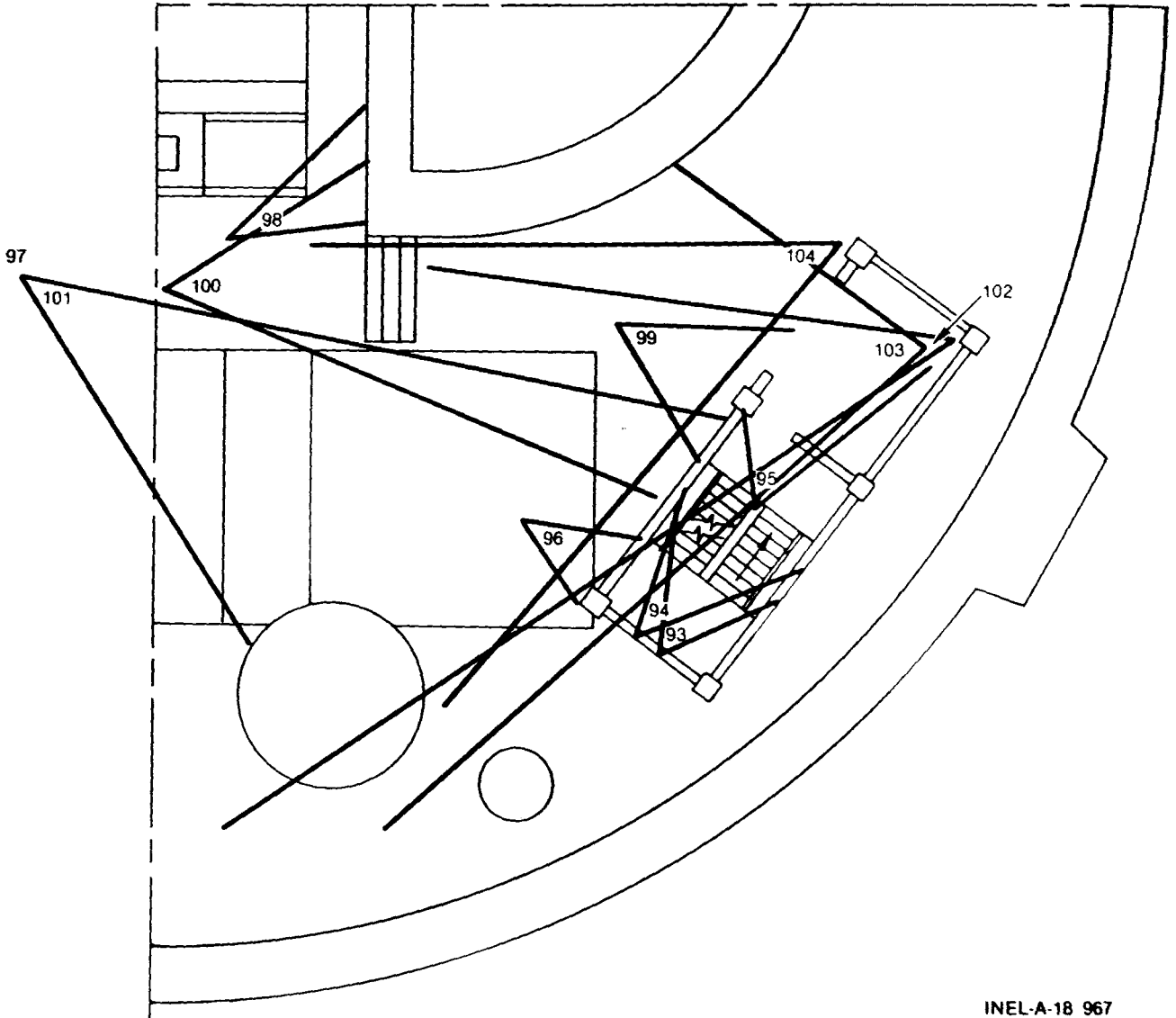

INEL-A-18 967

Figure ix-1. Map for Figures 93-104.

Elevation 347, Quadrant 1

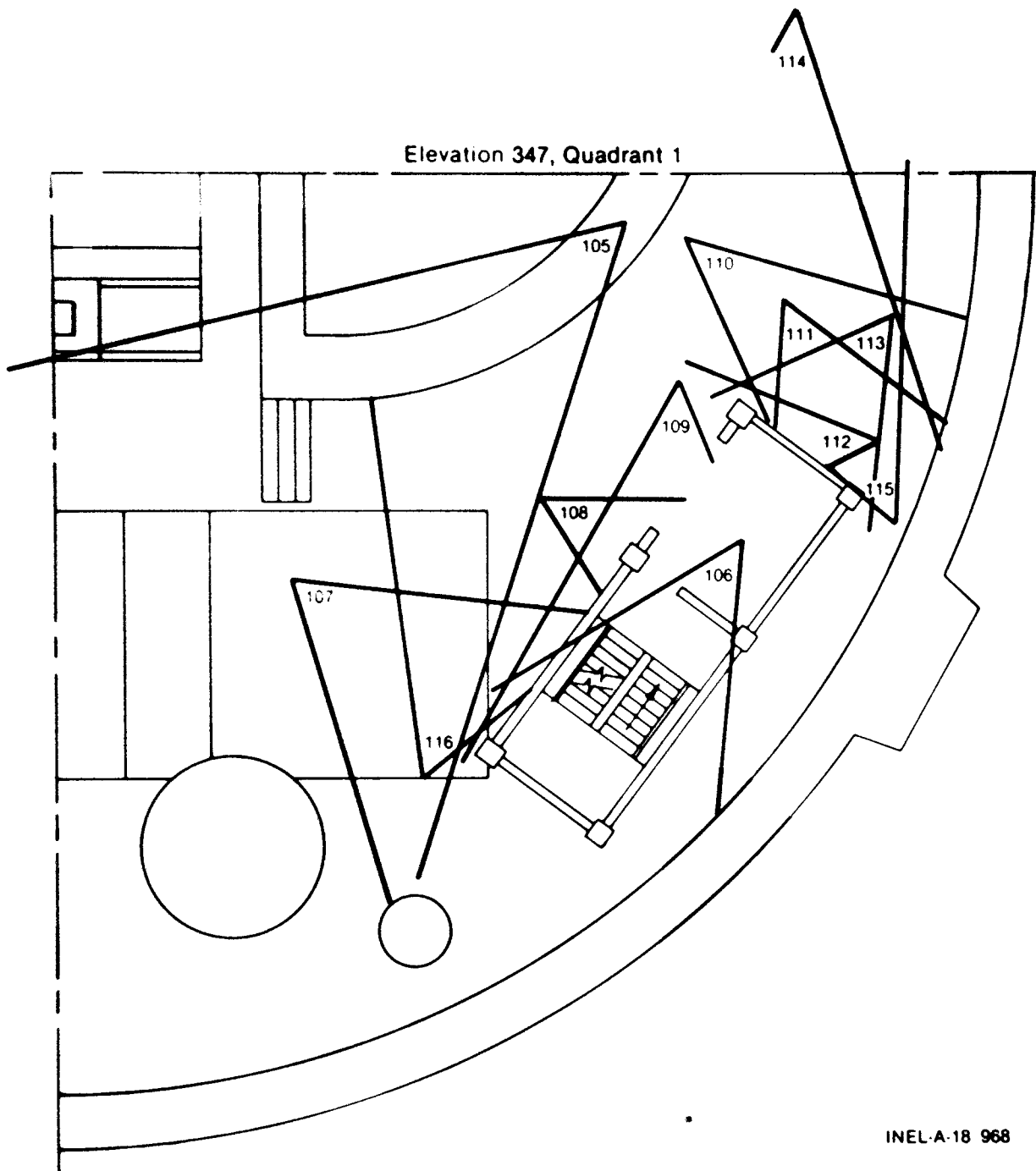

INEL-A-18 968

Figure ix-2. Map for Figures 105-116.

Elevation 347, Quadrant 1

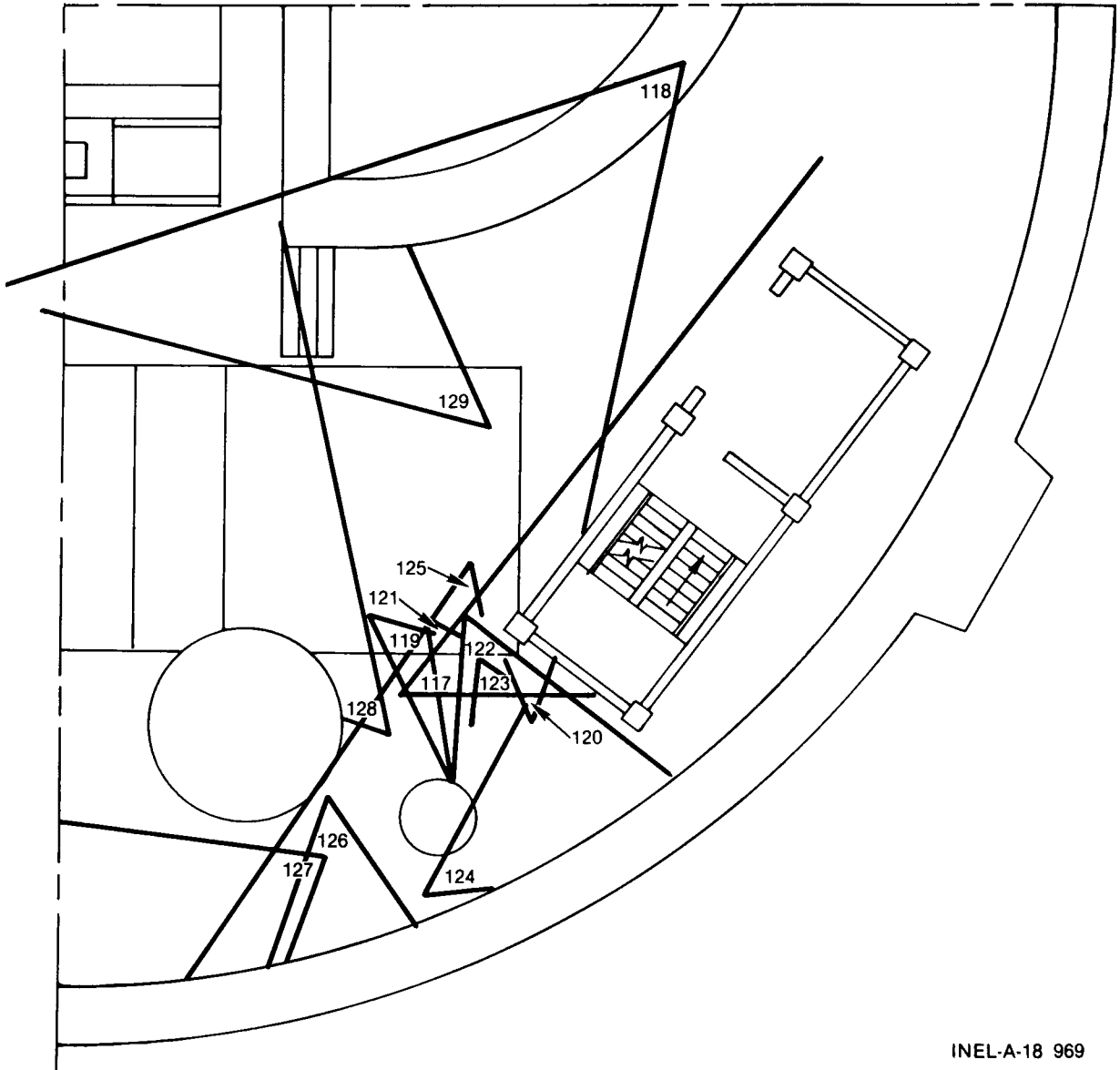

INEL-A-18 969

Figure ix-3. Map for Figures 117-129.

Elevation 347, Quadrant 2

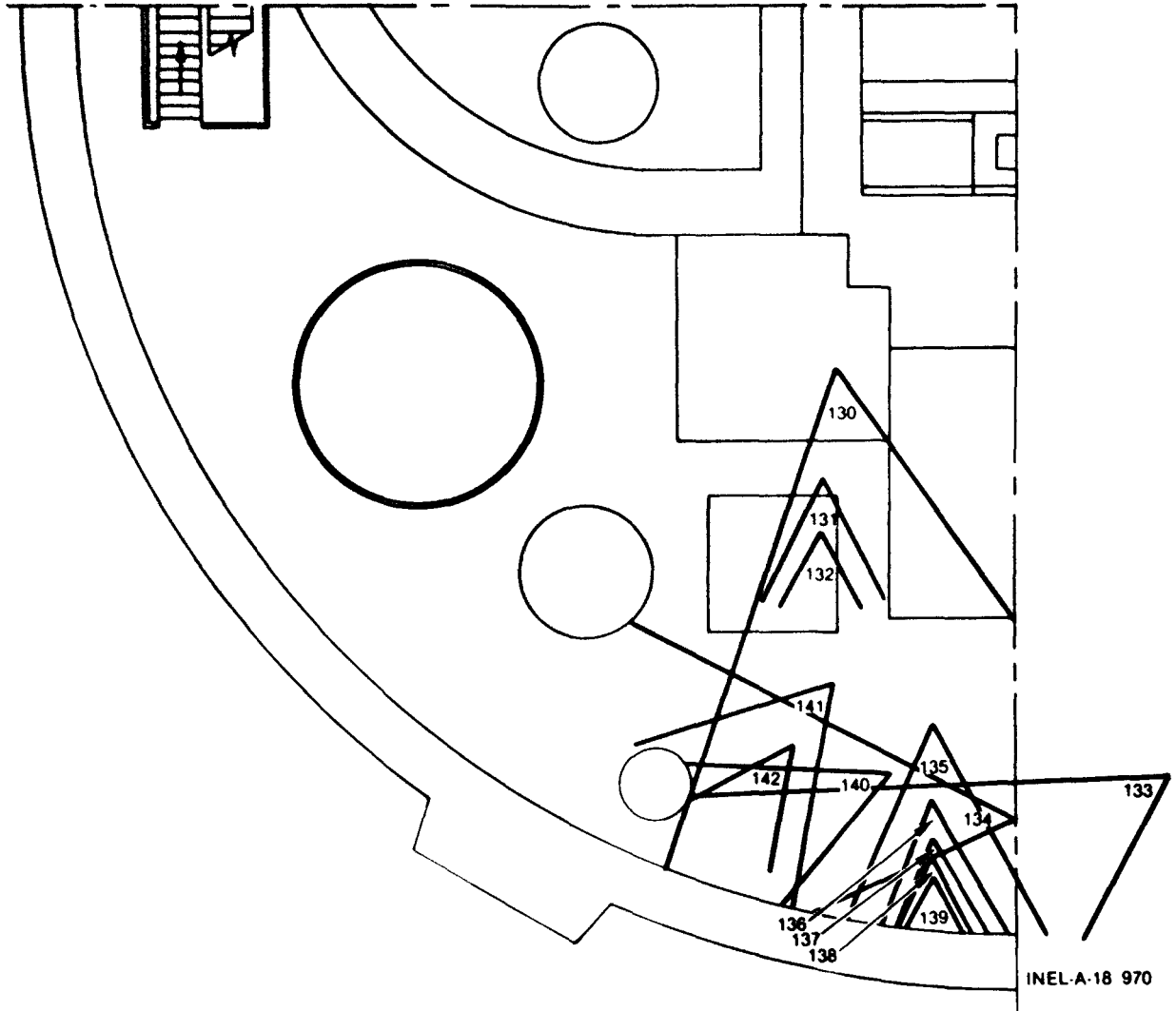

Figure x-1. Map for Figures 130-142.

Elevation 347, Quadrant 2

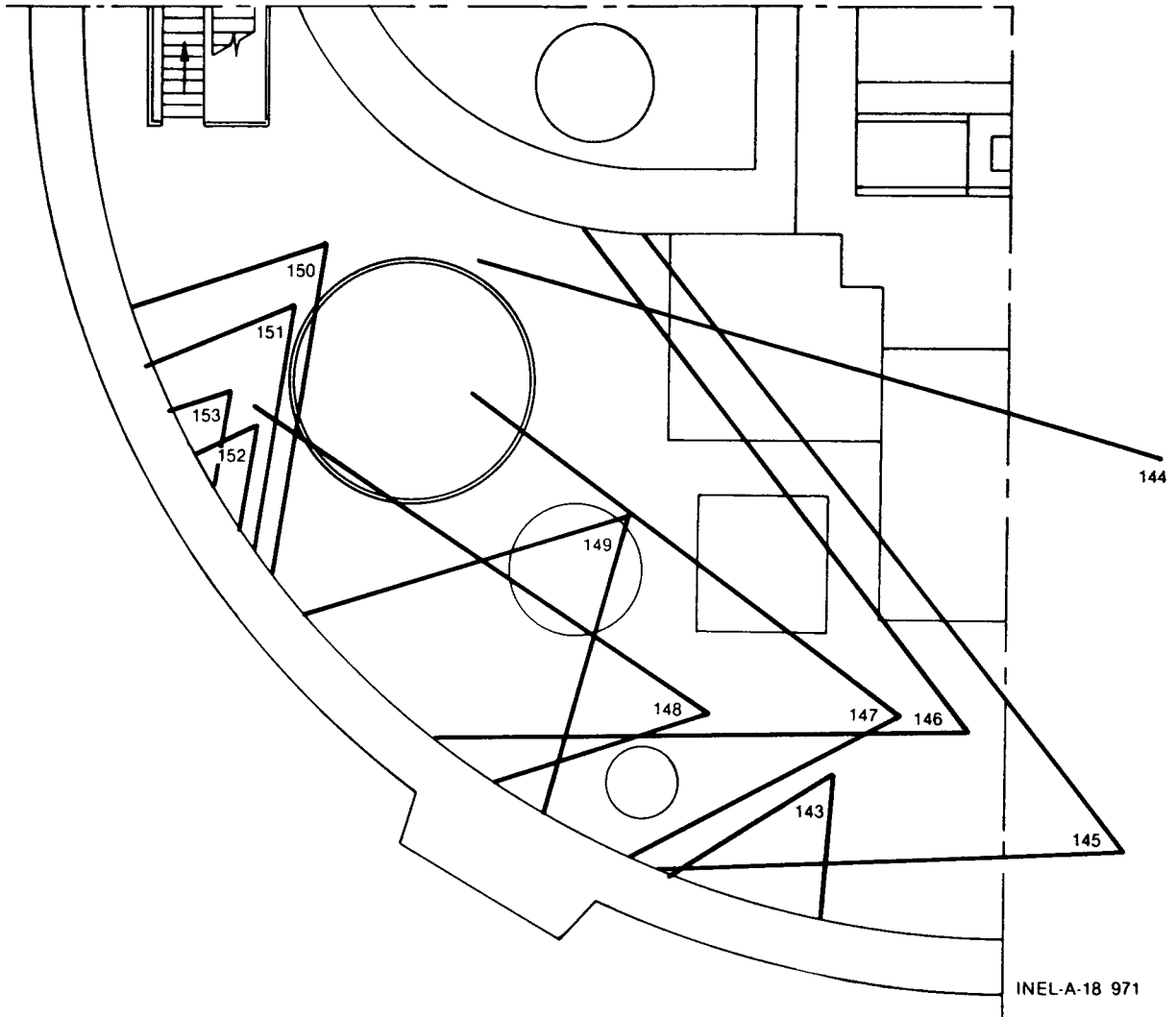
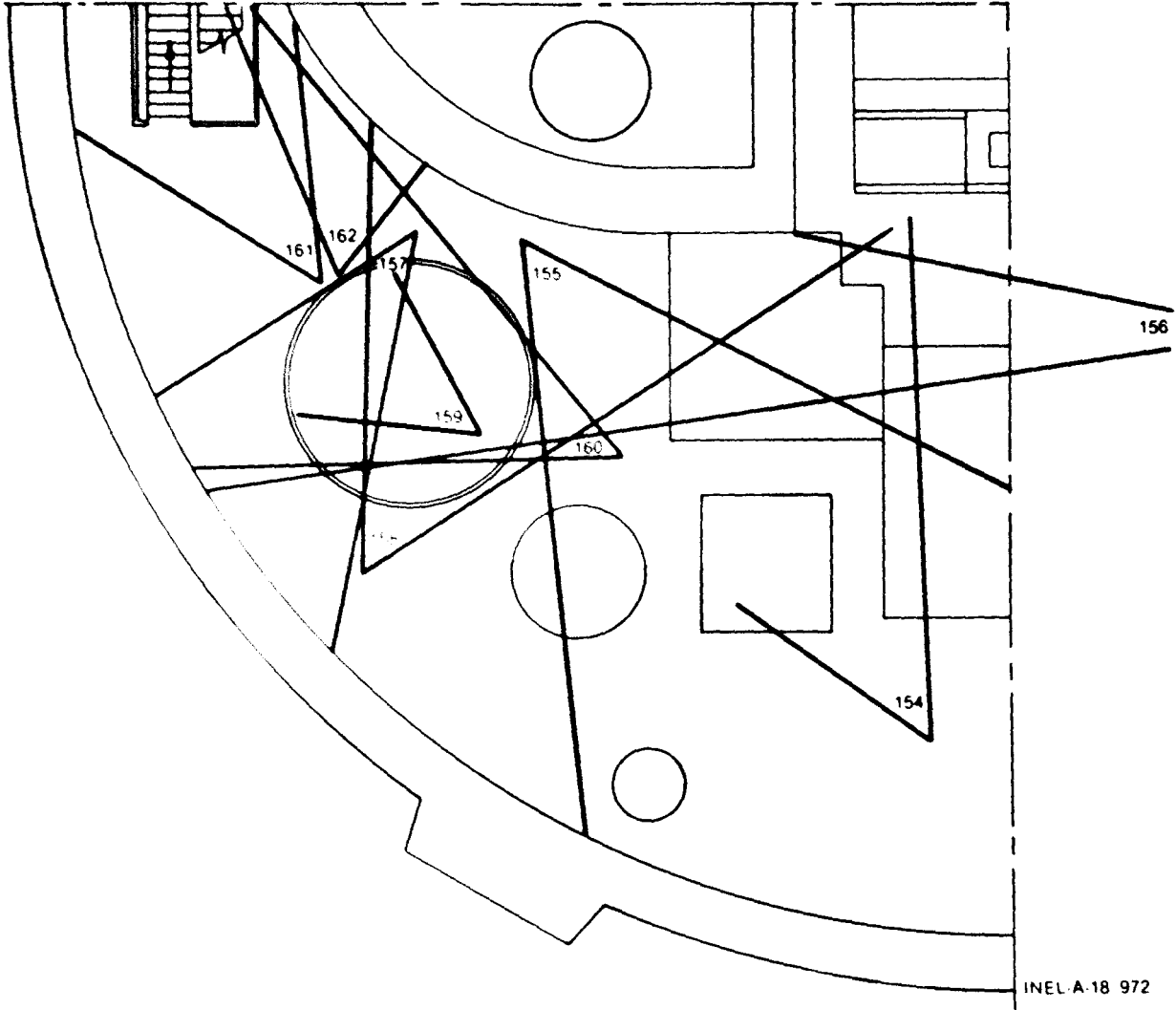

Figure x-2. Map for Figures 143-153.

Elevation 347, Quadrant 2



INEL-A-18 972

Figure x-3. Map for Figures 154-162.

Elevation 347, Quadrant 2

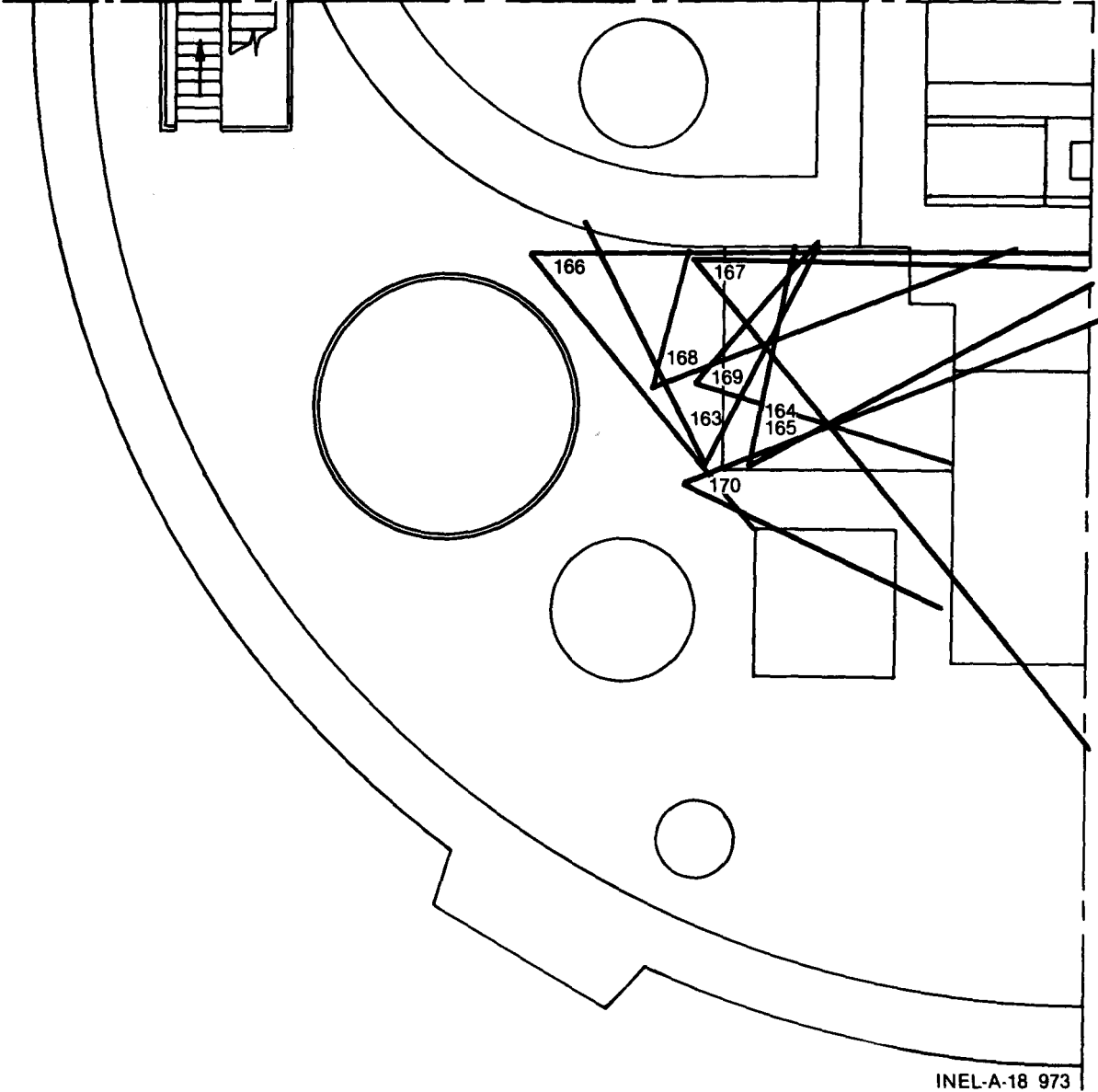
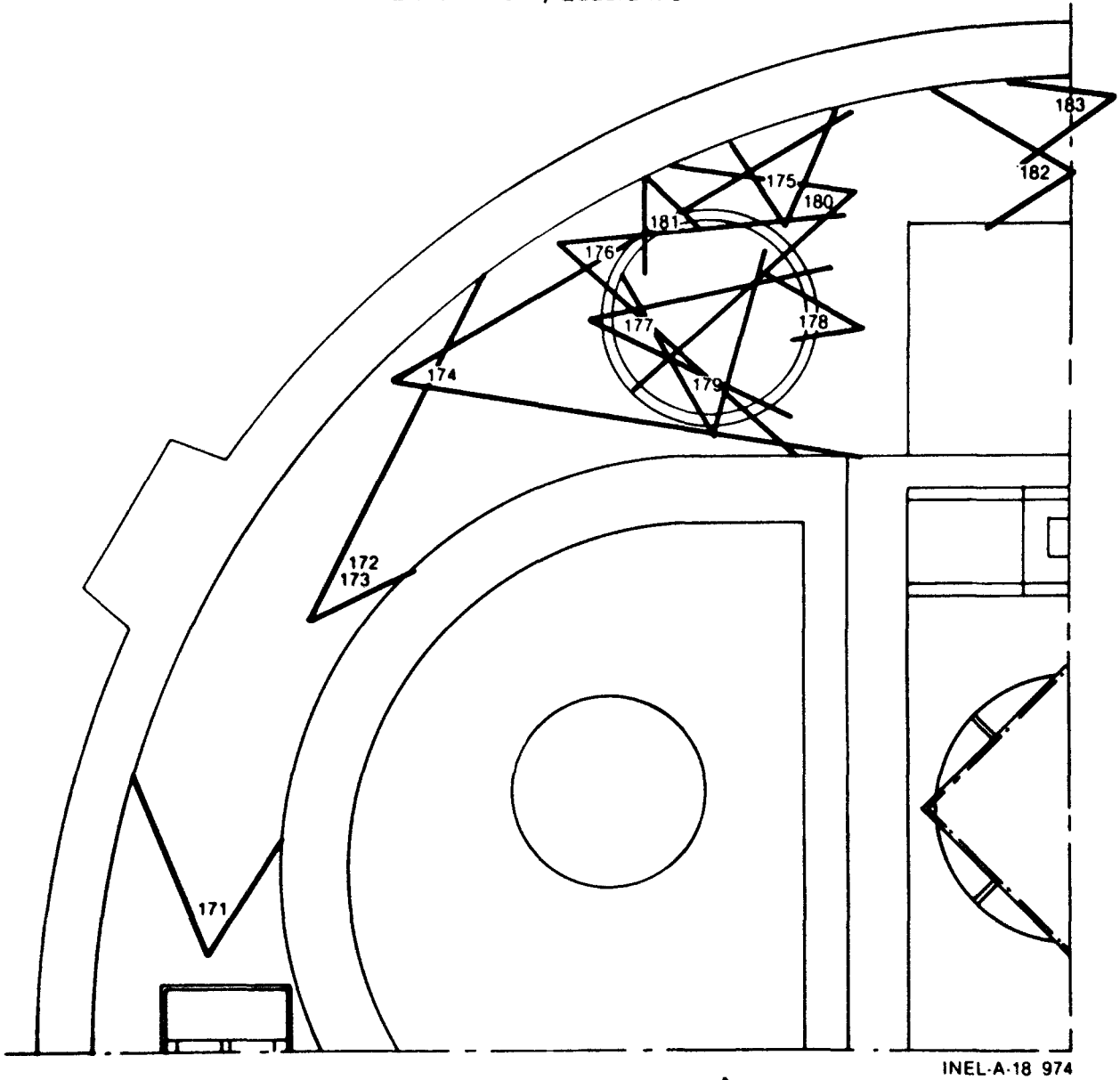

Figure x-4. Map for Figures 163-170.

Elevation 347, Quadrant 3



INEL-A-18 974

Figure xi-1. Map for Figures 171-183.

Elevation 347, Quadrant 4

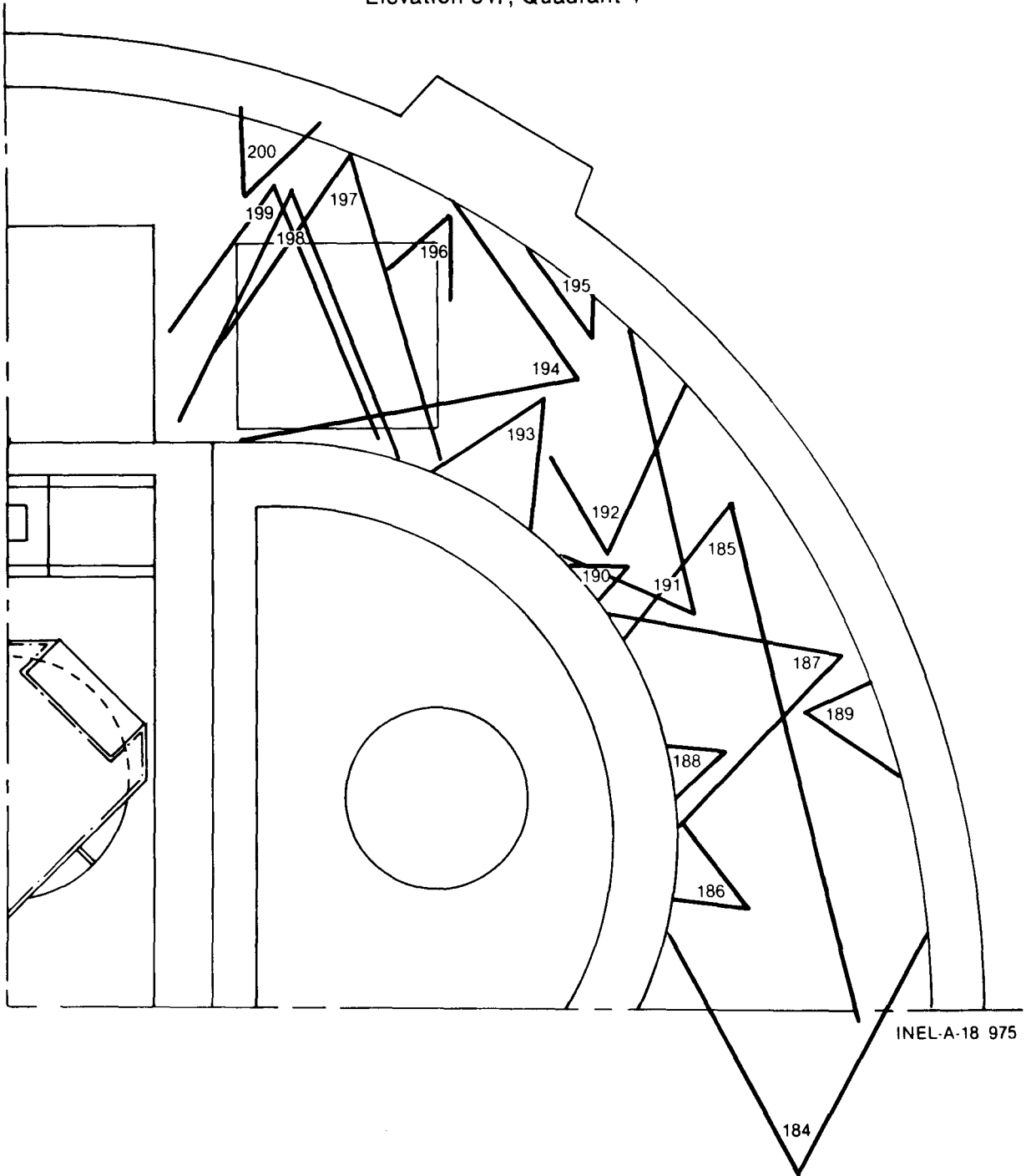

INEL-A-18 975

Figure xii-1. Map for Figures 184-200.

D Ring A

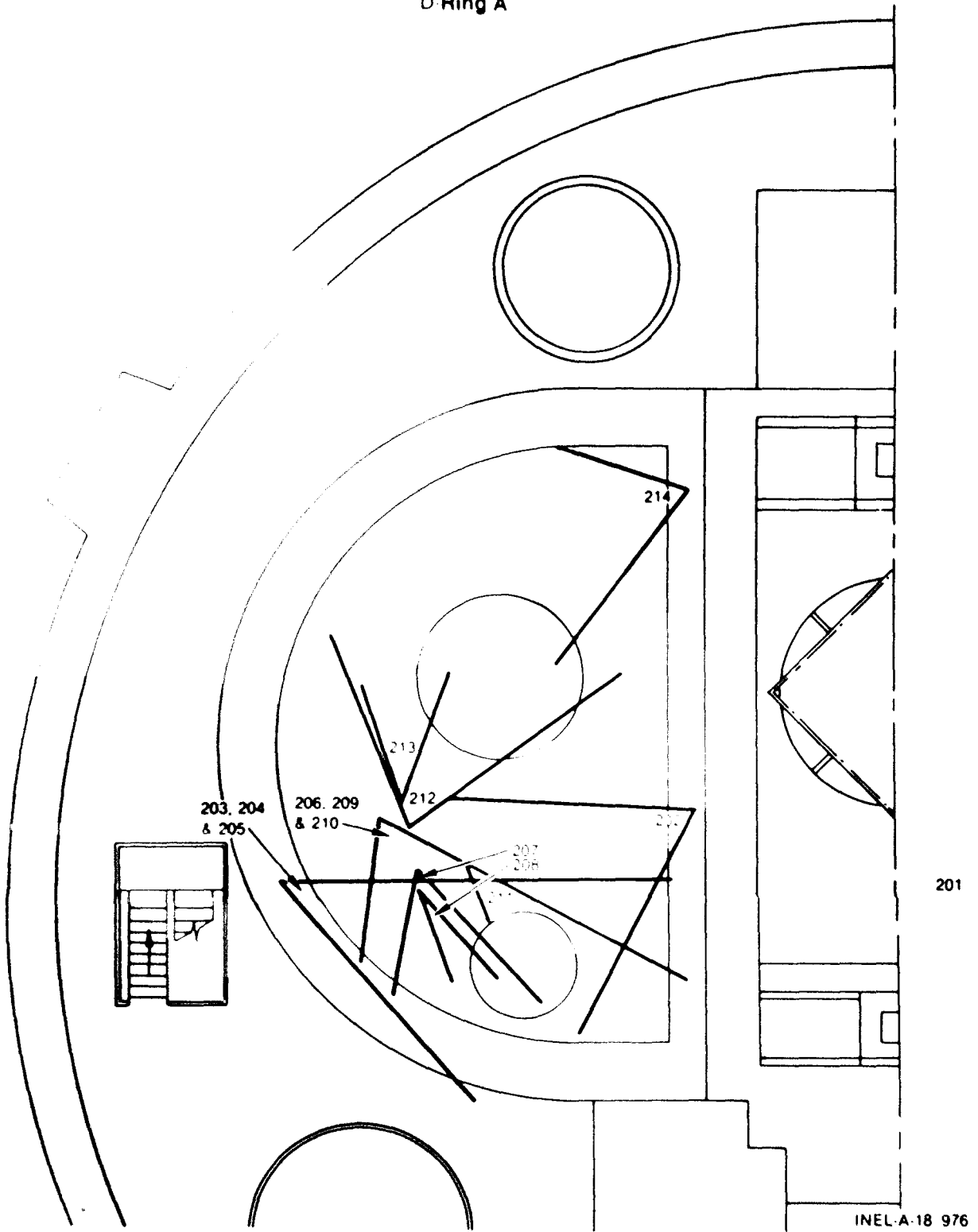

Figure XIII-1. Map for Figures 201-214.

D-Ring B

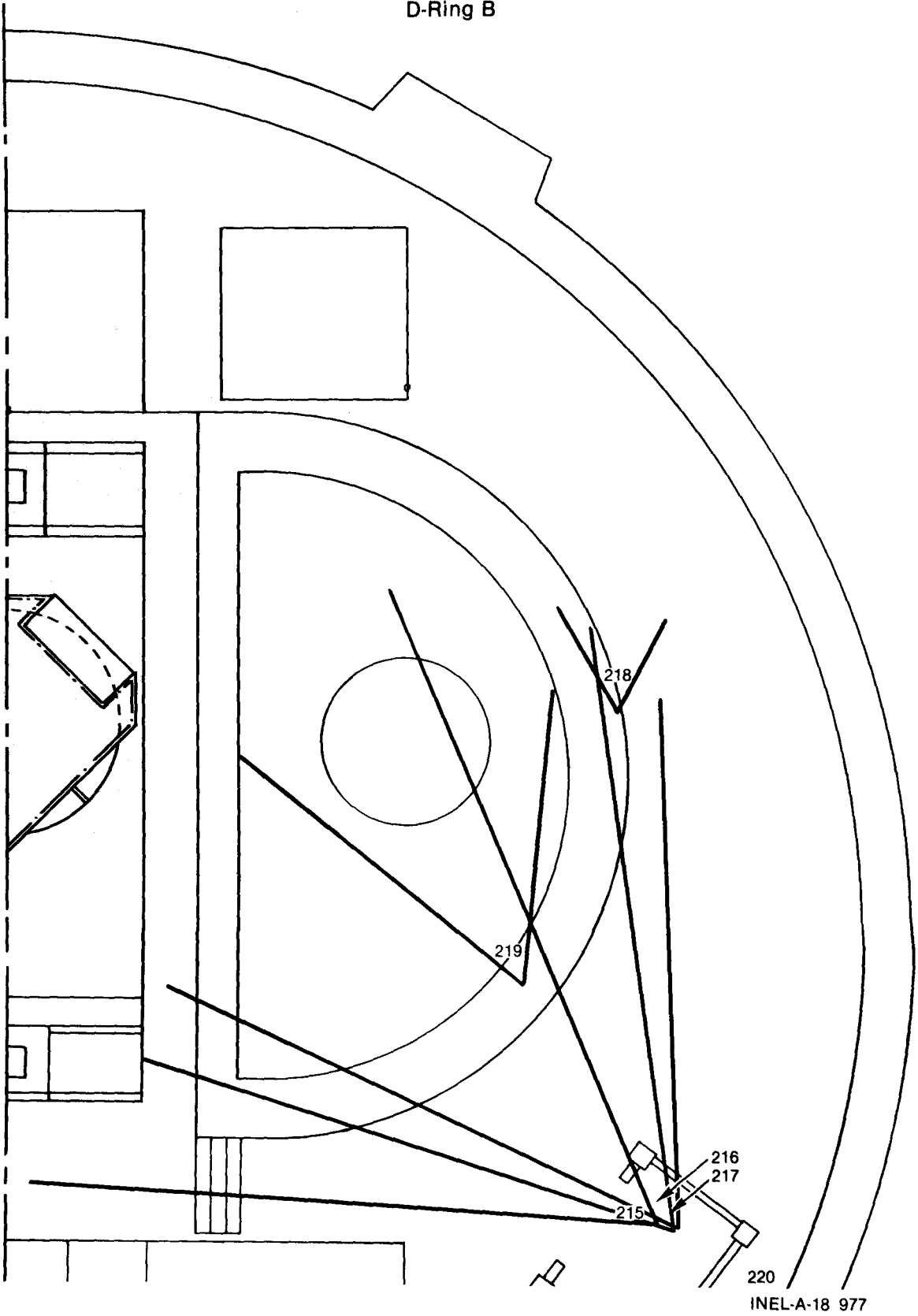

Figure xiv-1. Map for Figures 215-220.

Fuel Pool Area

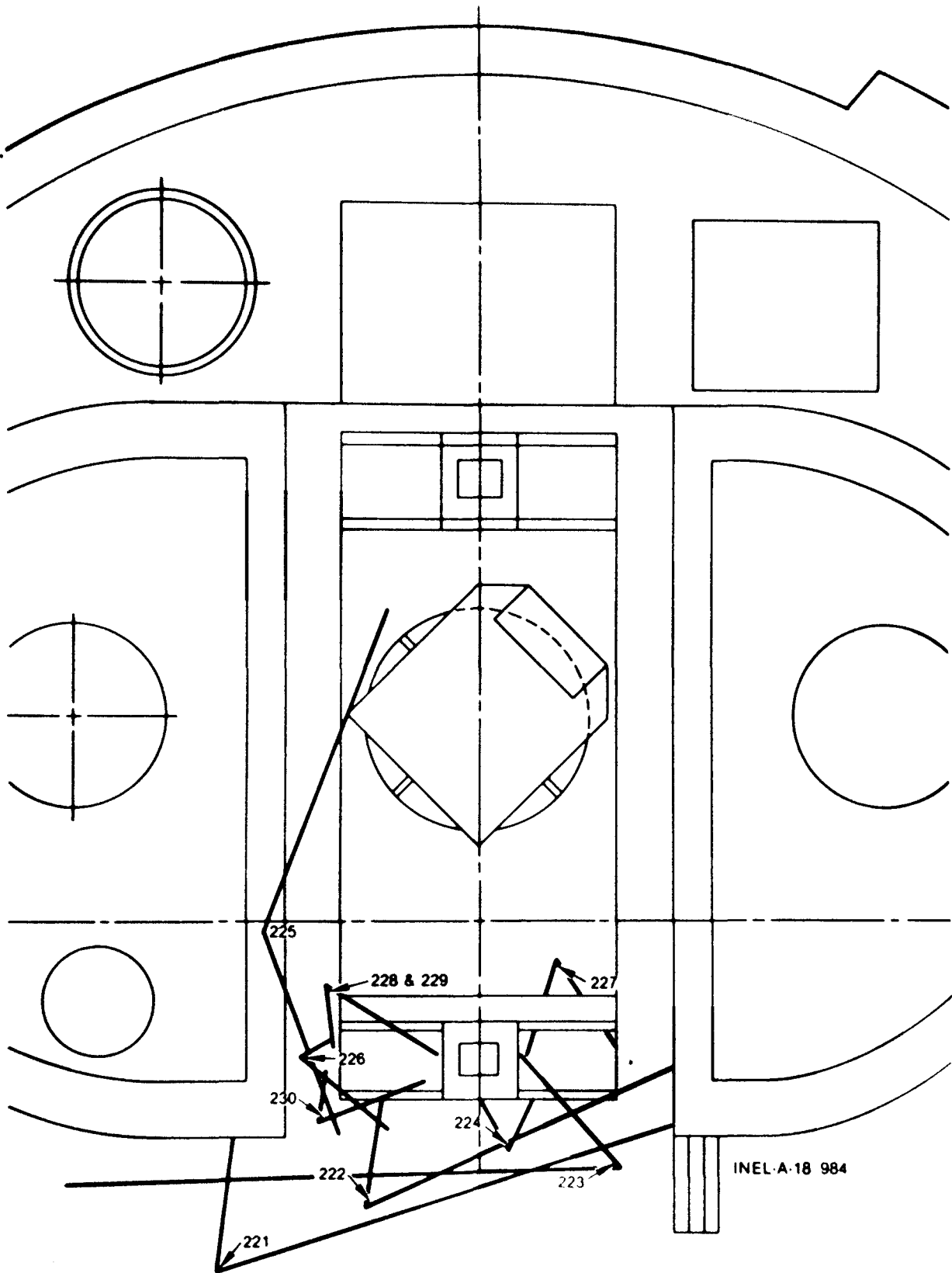

Figure xv-1. Map for Figures 221-230.

Fuel Pool Area

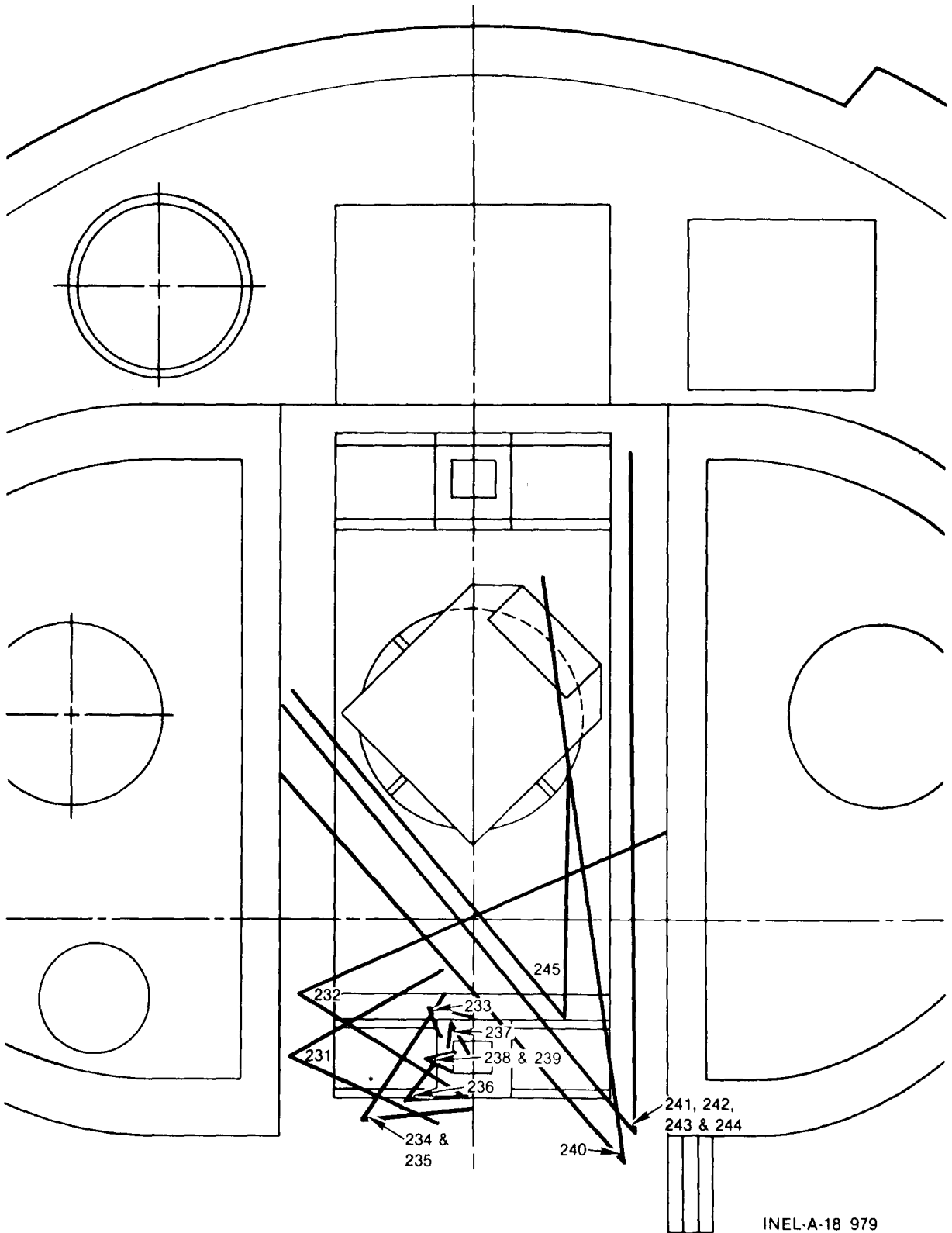

Figure xv-2. Map for Figures 231-245.

Fuel Pool Area

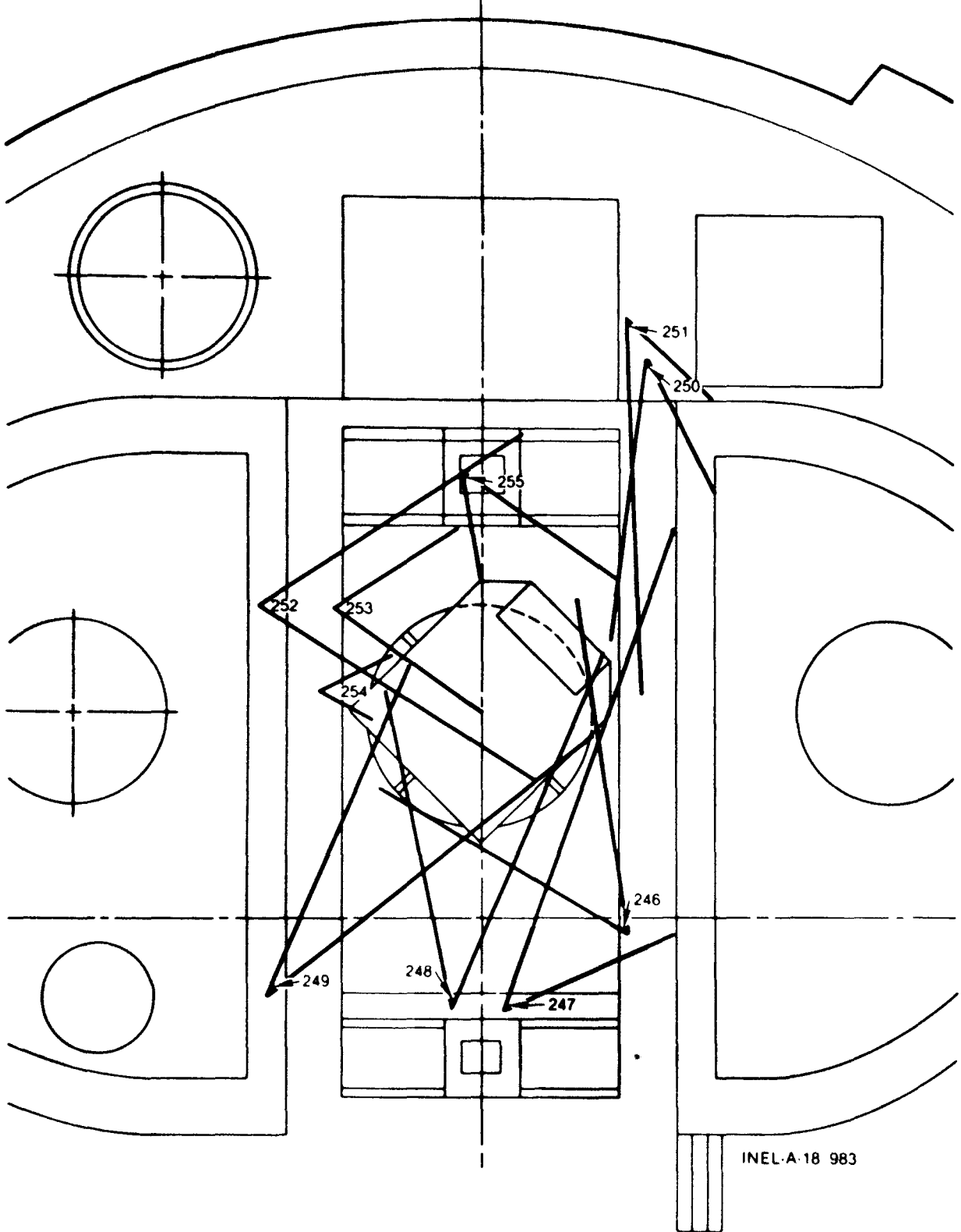
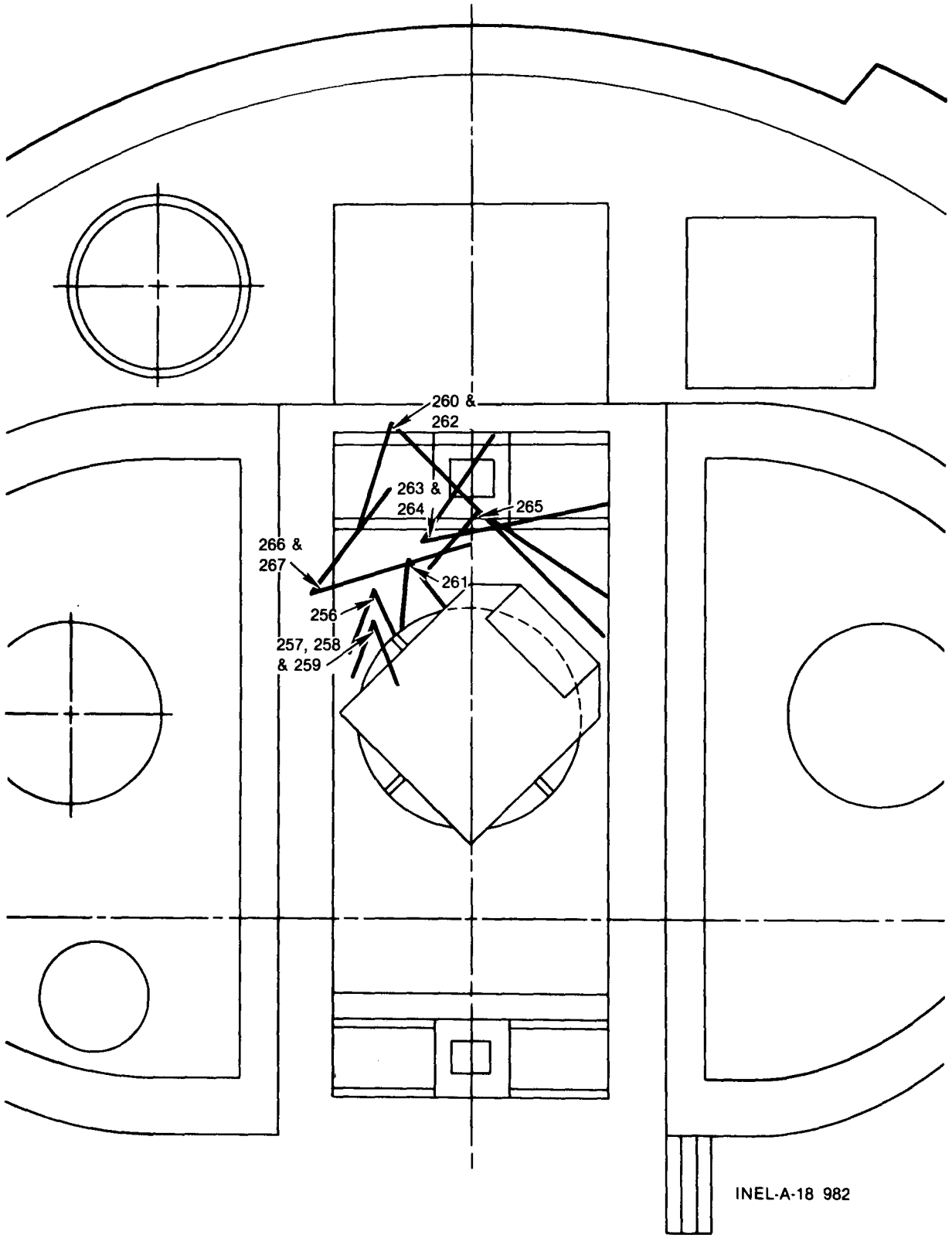

Figure xv.3. Map for Figures 246-255.

Fuel Pool Area



INEL-A-18 982

Figure xv-4. Map for Figures 256-267.

Crane Elevations

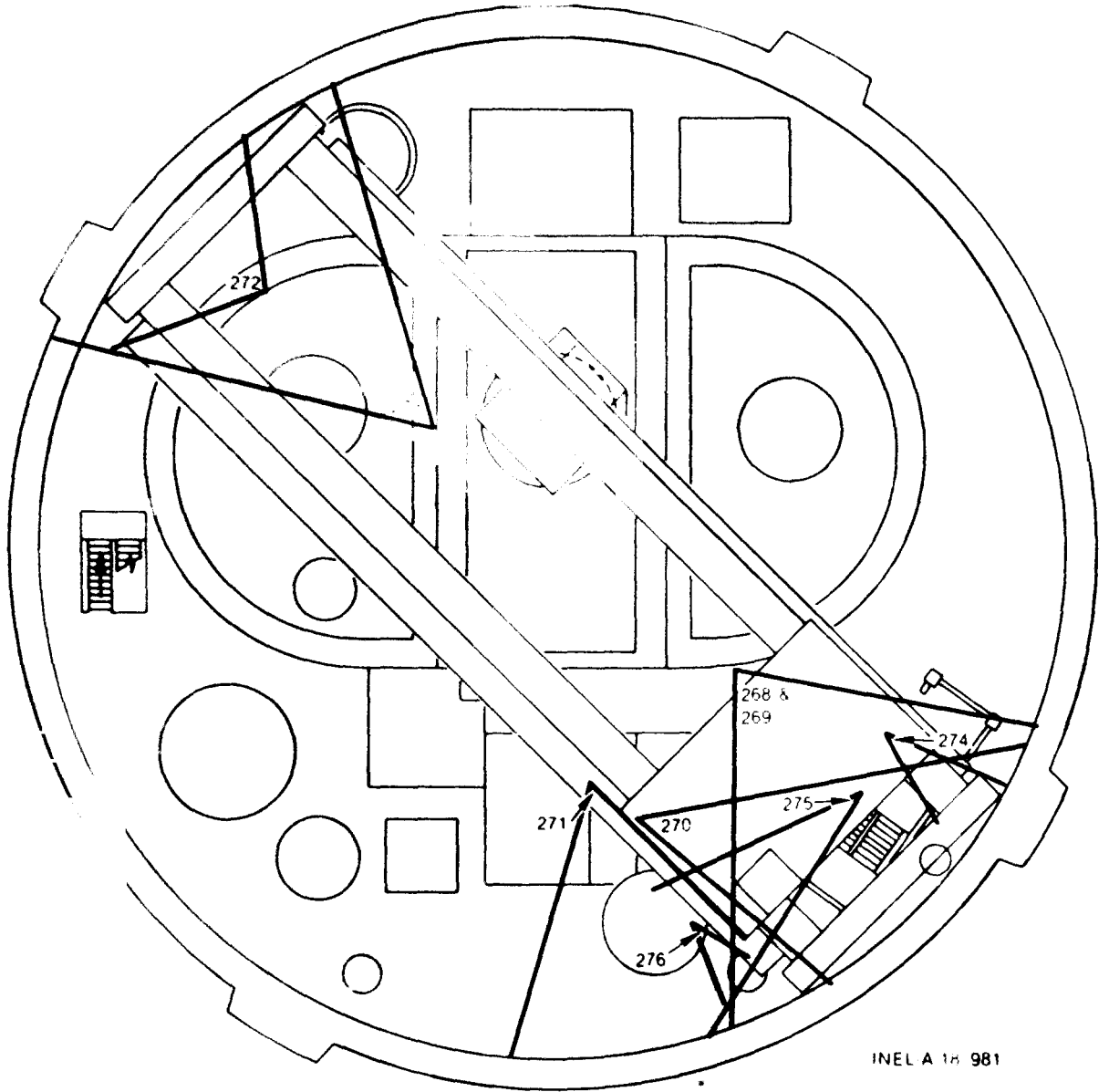

INEL A 16 981

Figure xvi-1. Map for Figures 268-276.

Crane Elevations

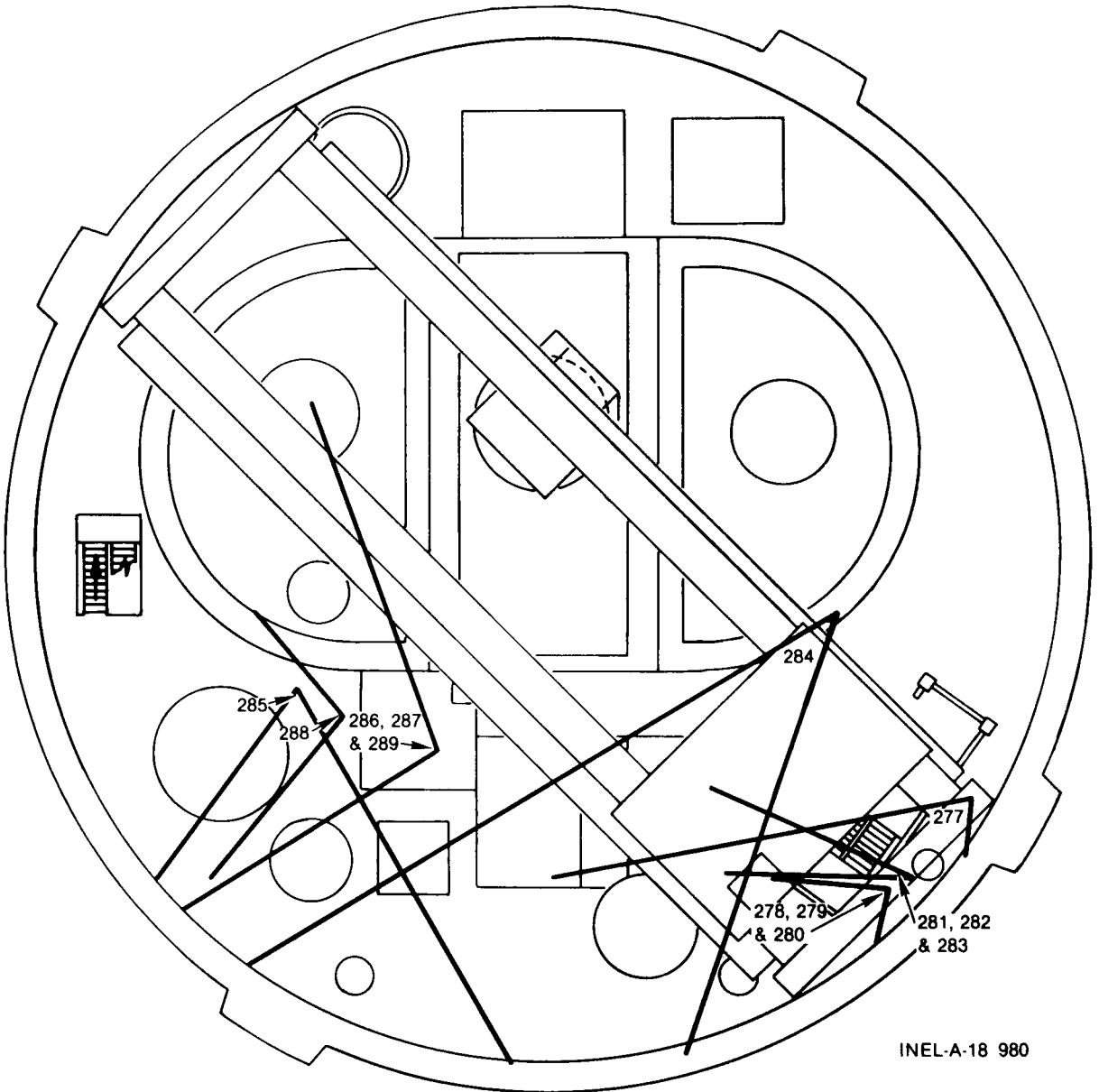

INEL-A-18 980

Figure xvi-2. Map for Figures 277-289.

Crane Elevations

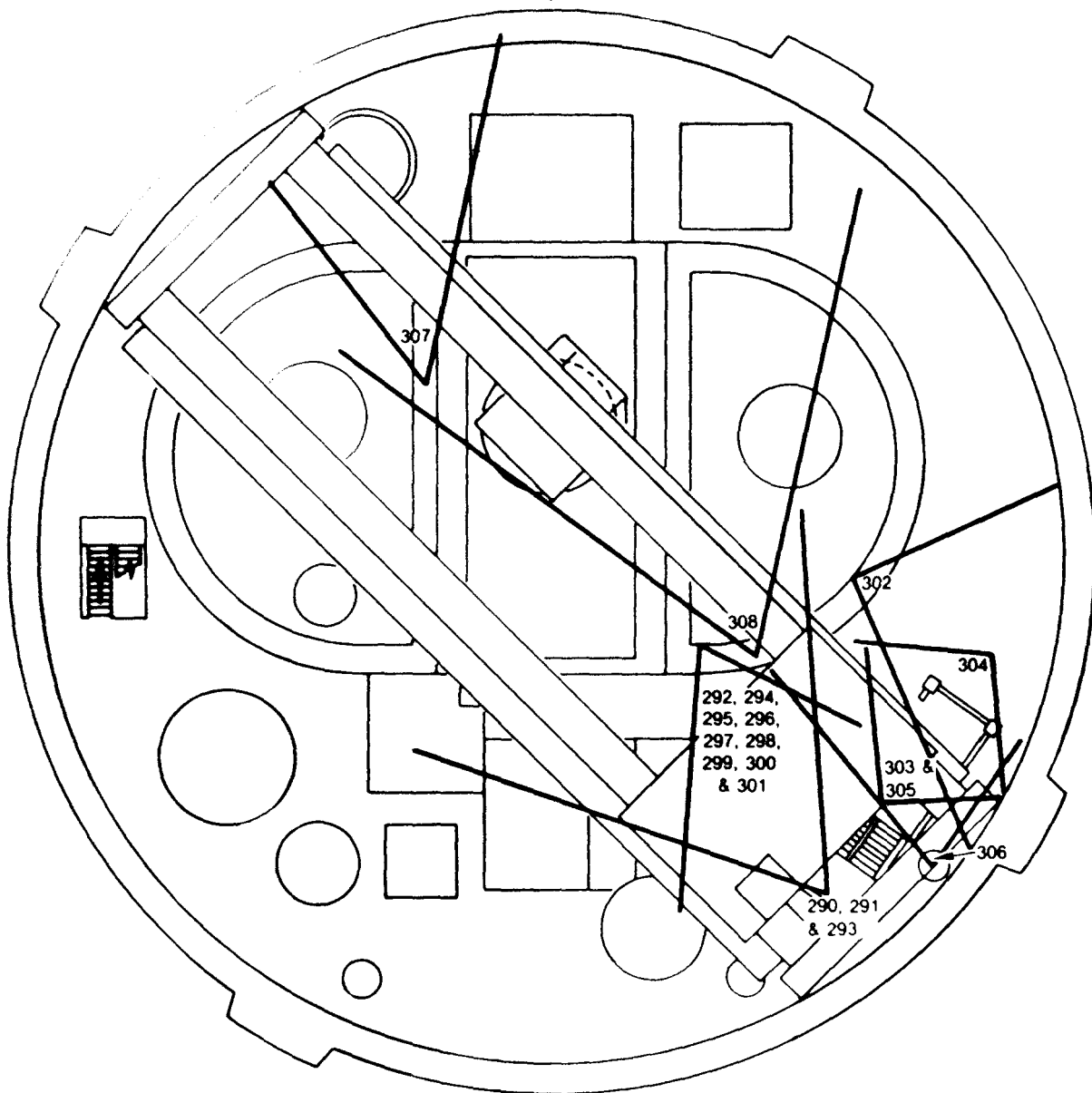

INEL-A-18 978

Figure xvi-3. Map for Figures 290-308.

FIGURES

Section B: Photographs Taken During Entries 1, 2, 4, 5, 6

ELEVATION 305

QUADRANT 1



Figure 1 (4A). Anteroom entry ramp into personnel air lock 2.



Figure 2 (4A). Anteroom; personnel air lock 2 at right.

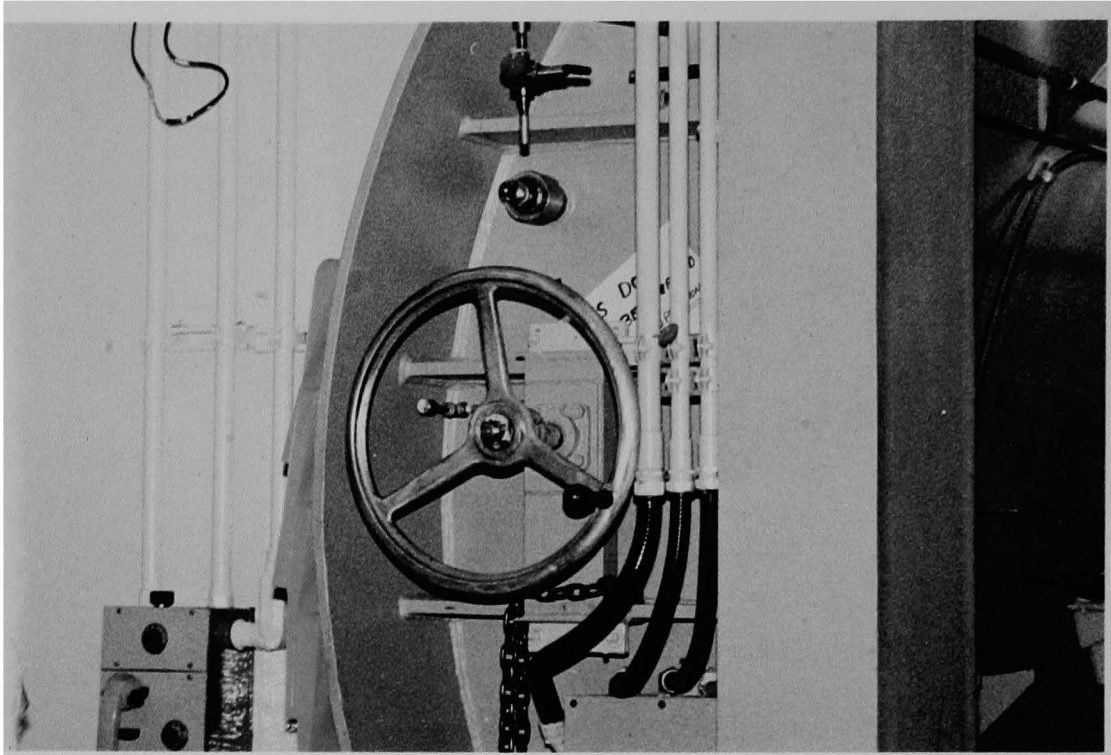

Figure 3 (5B). Handwheel on anteroom side of air lock 2.



Figure 4 (5B). Technician standing within doorway of personnel air lock 2.



Figure 5 (2A). Technicians setting up decontamination test equipment inside of containment; air lock 2 in background, elevator door right.

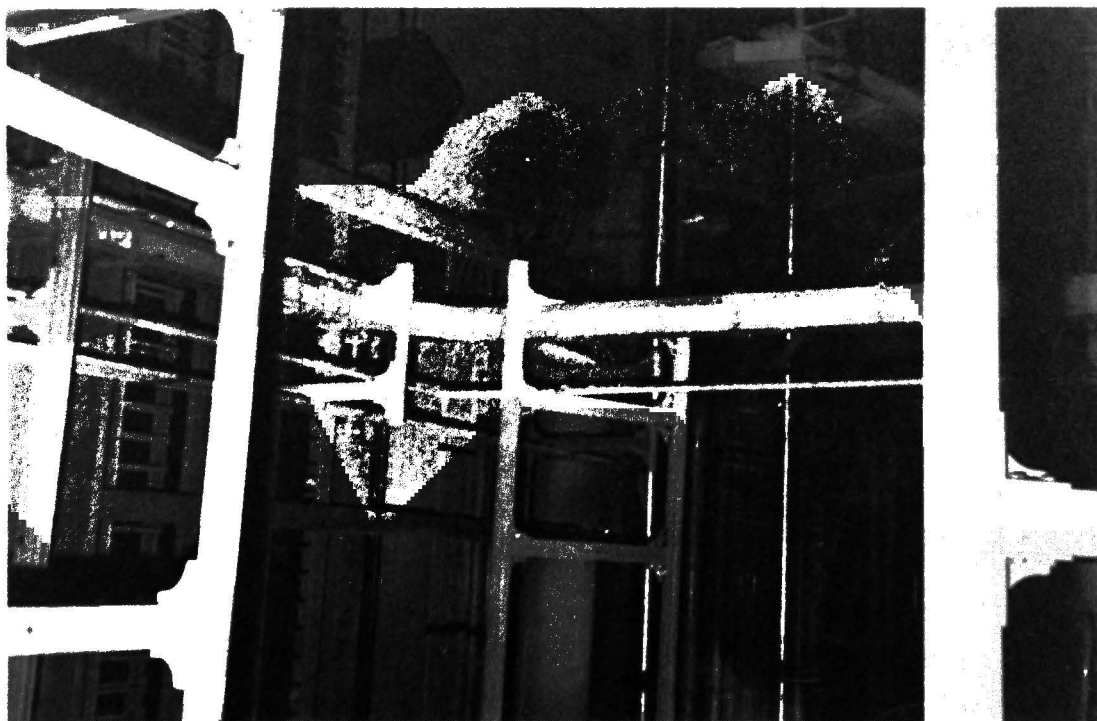

Figure 6 (6A). Northeast view along the containment wall from the platform on the elevator shaft between elevation 305 and 347 (see Figure 14); electrical penetrations visible in background.



Figure 7 (1A). Gloves and coiled hose on cart just north of personnel air lock 2.

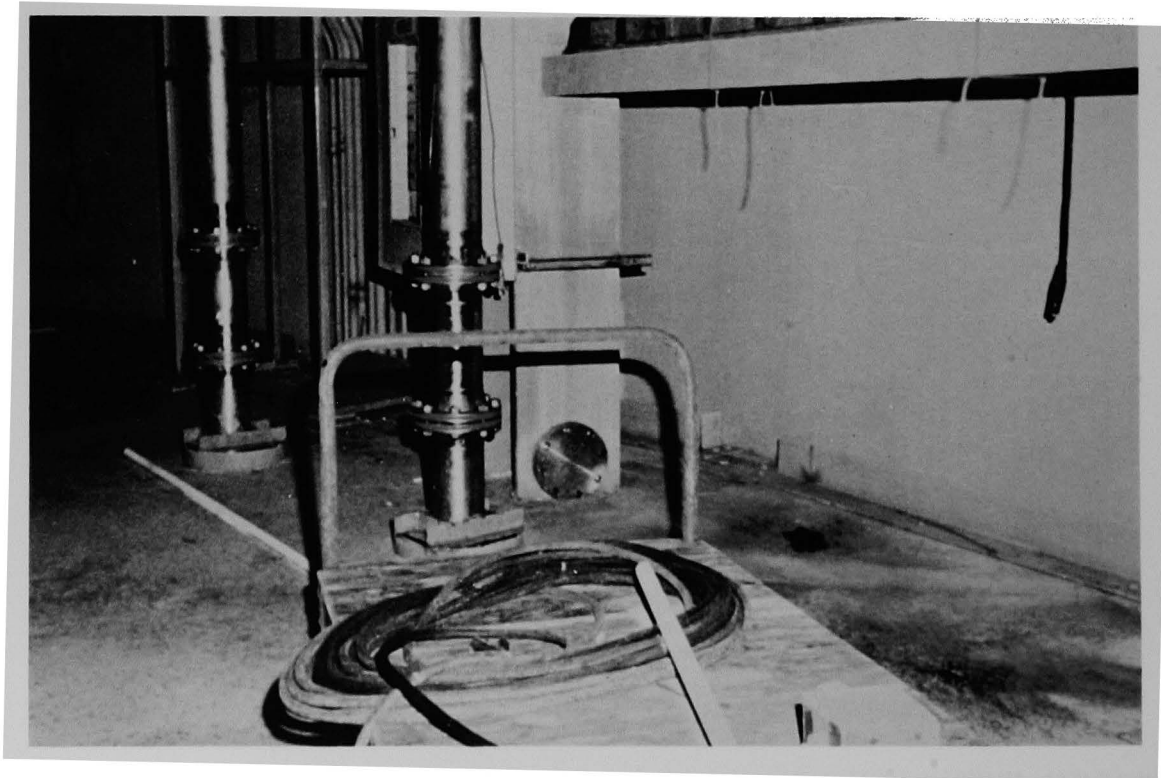

Figure 8 (1A). Coiled hose on north end of card; reactor building spray lines in background.



Figure 9 (2B). Technician removing HP-R-211 radiation monitor from northeast elevator wall.

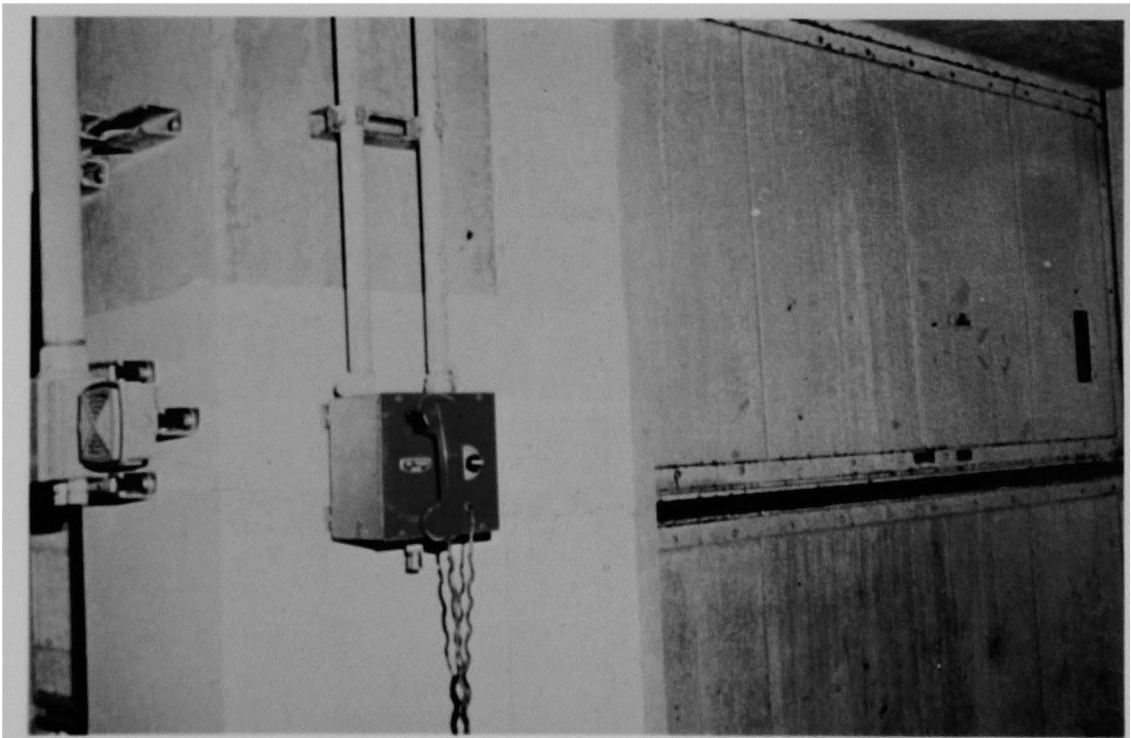

Figure 10 (1A). Gai-tronic telephone and elevator door.



Figure 11 (4A). Surface detail of Gai-tronic phone and elevator door.

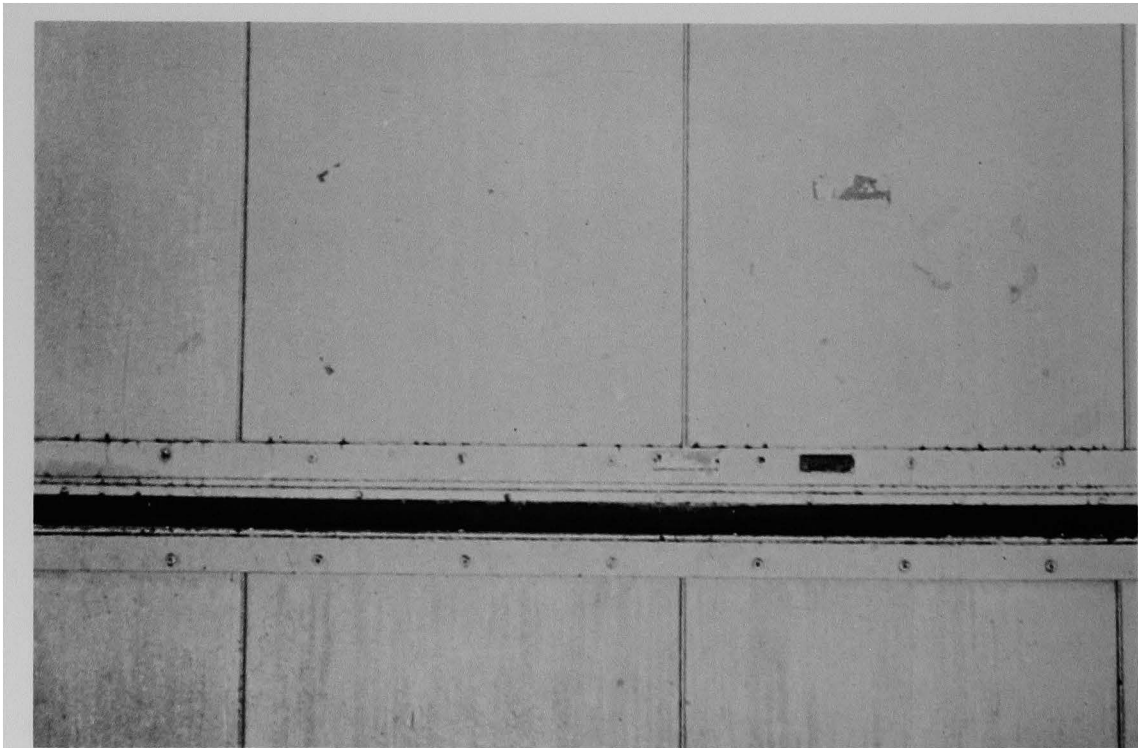

Figure 12 (1A). Close-up of elevator door at elevation 305.



Figure 13 (6A). Close-up of gap in elevator door.



Figure 14 (6A). Platform on the enclosed elevator-stairwell, view up from elevation 305.



Figure 15 (6A). Door and corner of platform on the enclosed elevator-stairwell (photograph turned sideways).



Figure 16 (6A). Inside of the elevator shaft, view through door shown in Figure 15.



Figure 17 (1A). Floor; covered hatch and air coolers in background.

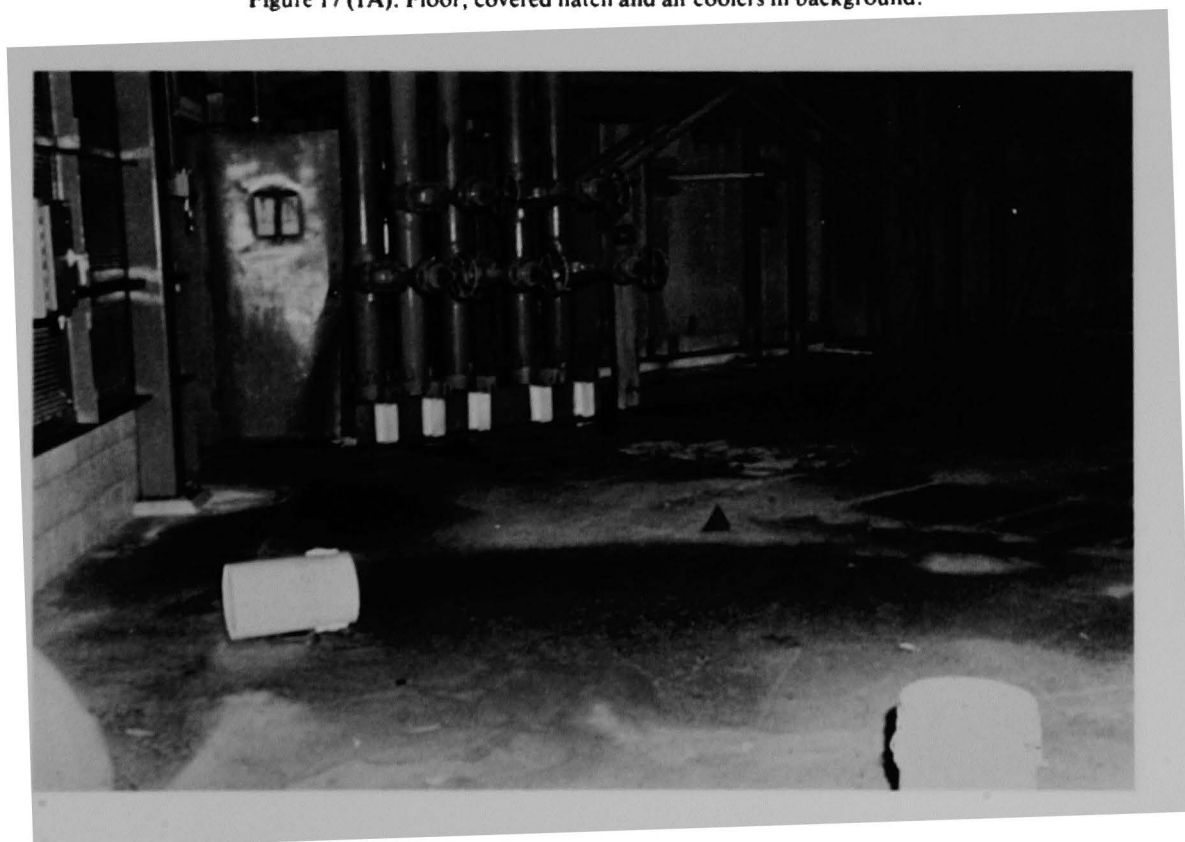

Figure 18 (1A). Floor; enclosed stairway door left, air coolers background right.



Figure 19 (1A). Floor drain and rusted funnel (center detail of Figure 18).



Figure 20 (2A). Covered hatch; air coolers right.

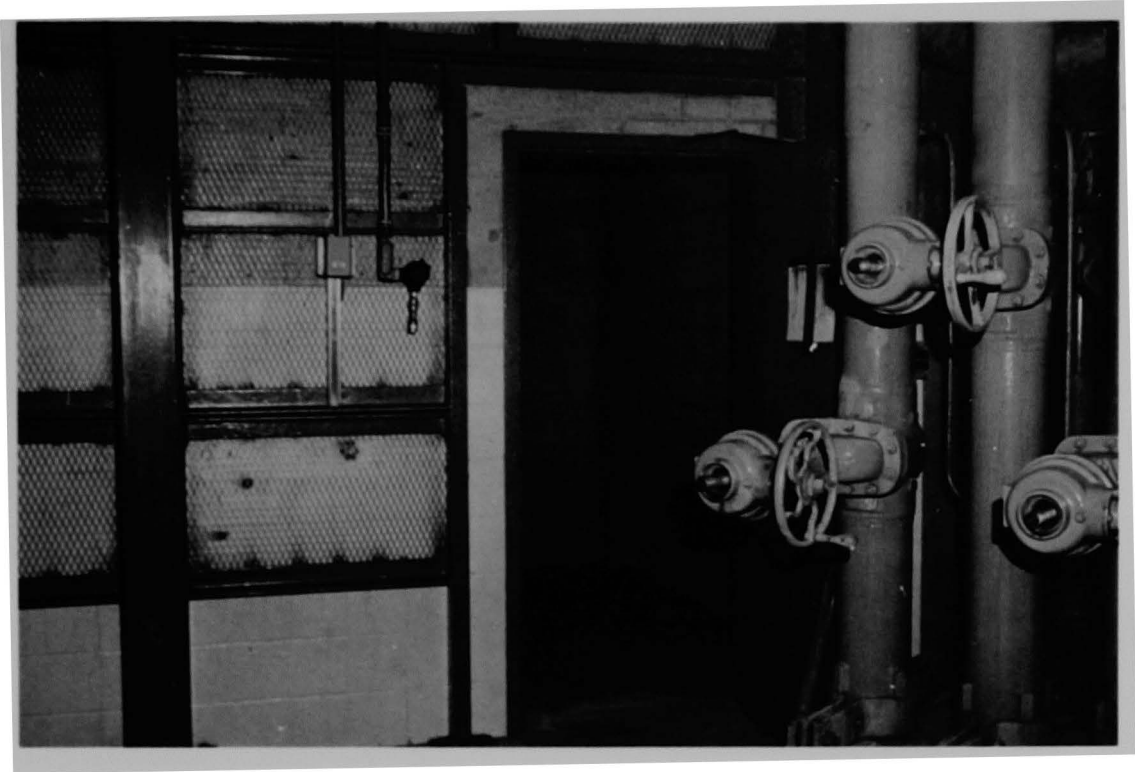

Figure 21 (4A). Door to enclosed stairway and river water piping to air coolers.

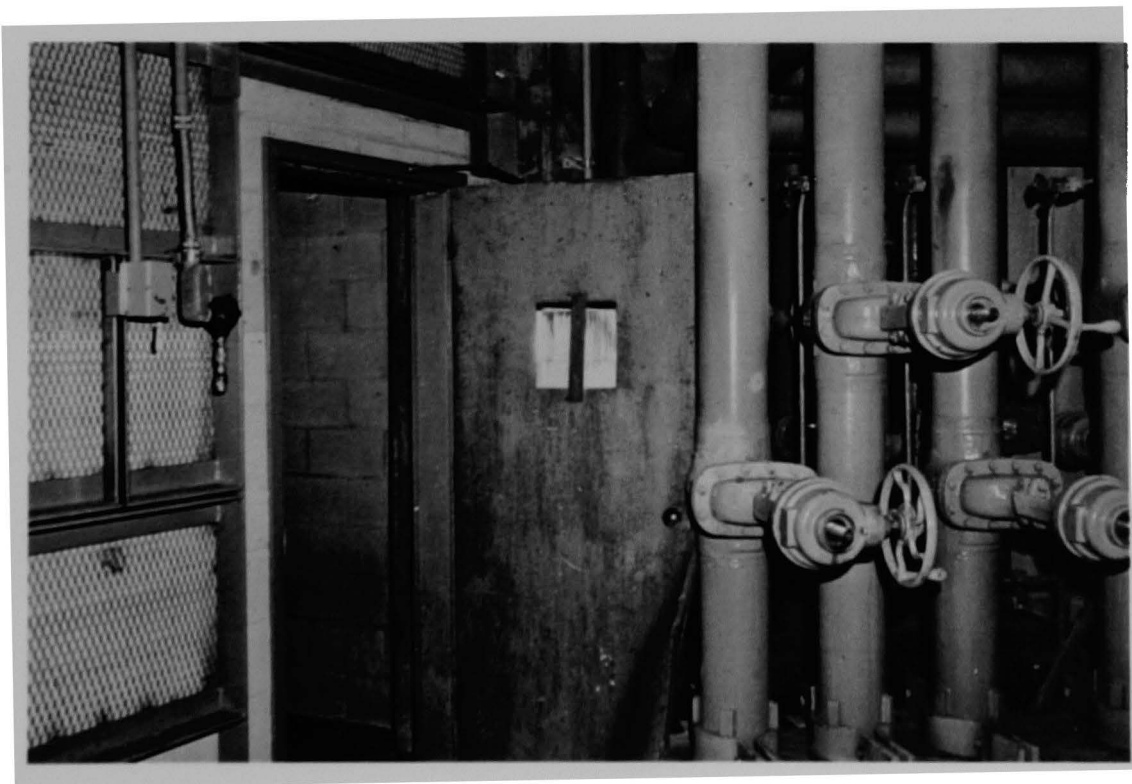

Figure 22 (4A). Door to enclosed stairway, thrust open against the river water piping associated with the air coolers.

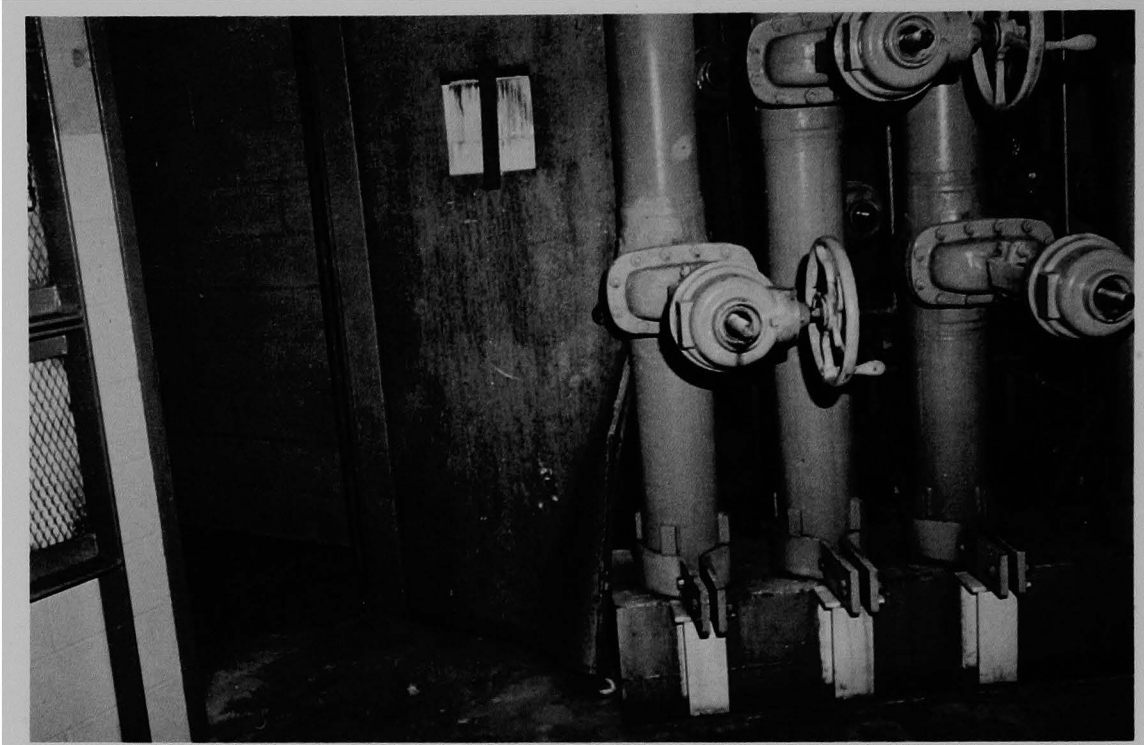

Figure 23 (4A). Lower portion of door to enclosed stairway.

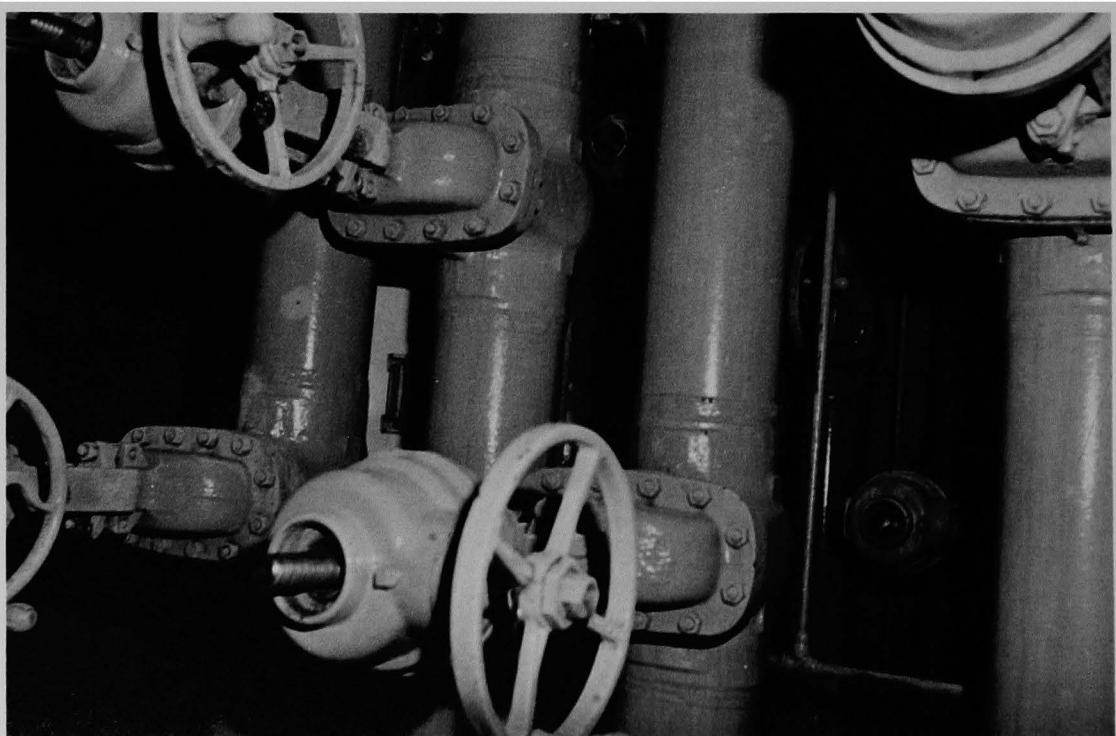

Figure 24 (2A). River water piping associated with air coolers; stairwell in background left.



Figure 25 (2A). Bottom corner of door to enclosed stairwell, thrust against structure of river water piping.



Figure 26 (1A). Close view of door to enclosed stairwell and river water piping to air cooling assembly.



Figure 27 (1A). Surface of door to enclosed stairway.



Figure 29 (6A). Close-up of landing within the enclosed stairwell.

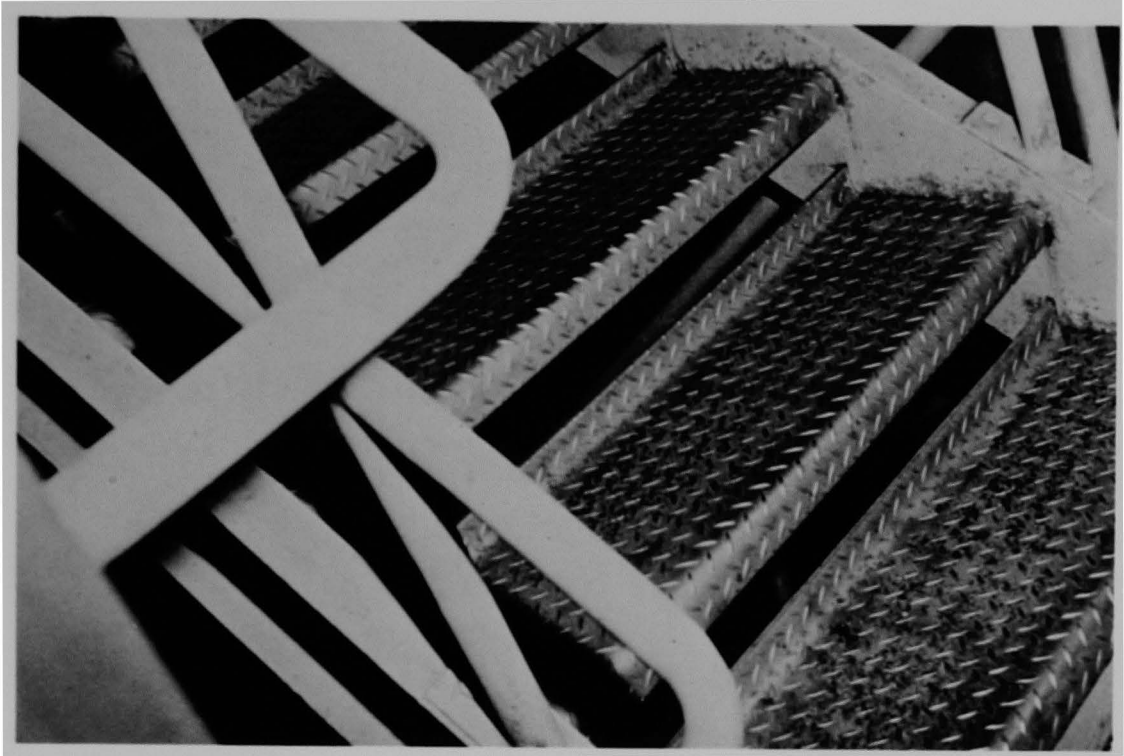

Figure 29 (1A). Enclosed stairs, beginning ascent from elevation 305.

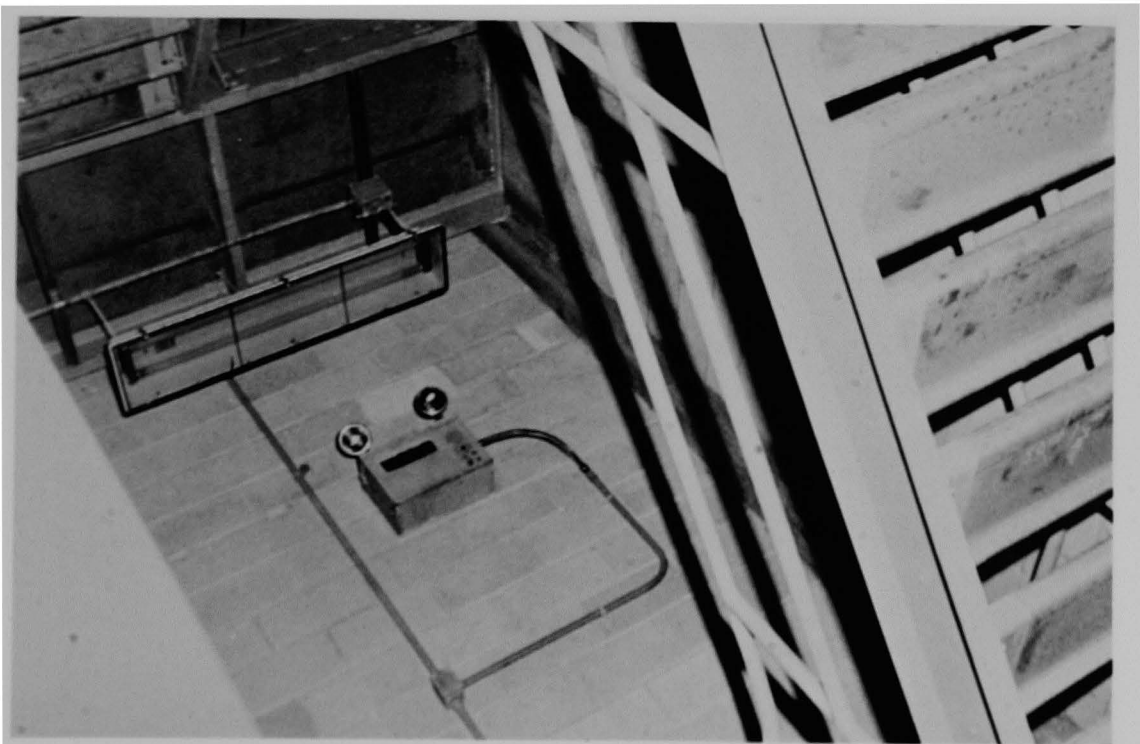

Figure 30 (1A). Emergency lights in enclosed stairwell, view up from elevation 305.

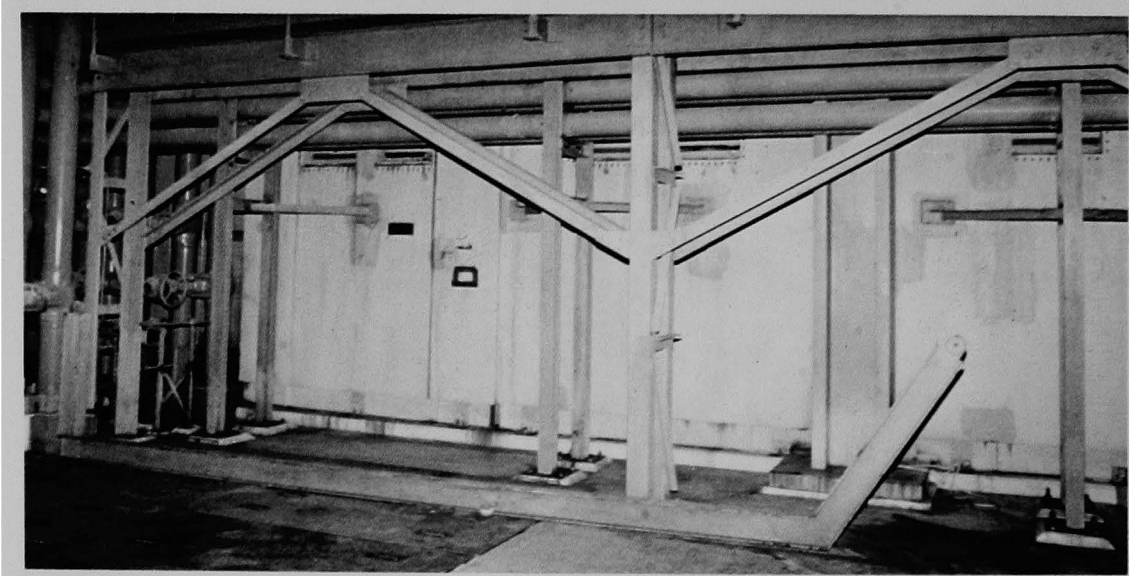

Figure 31 (5C). East units of air cooling assembly.



Figure 32 (6A). Portion of top section of the air coolers, view from platform on enclosed stairwell.



Figure 33 (1A). East units of air cooling assembly; river water piping at left.



Figure 34 (1A). Close-up of river water piping associated with air coolers.

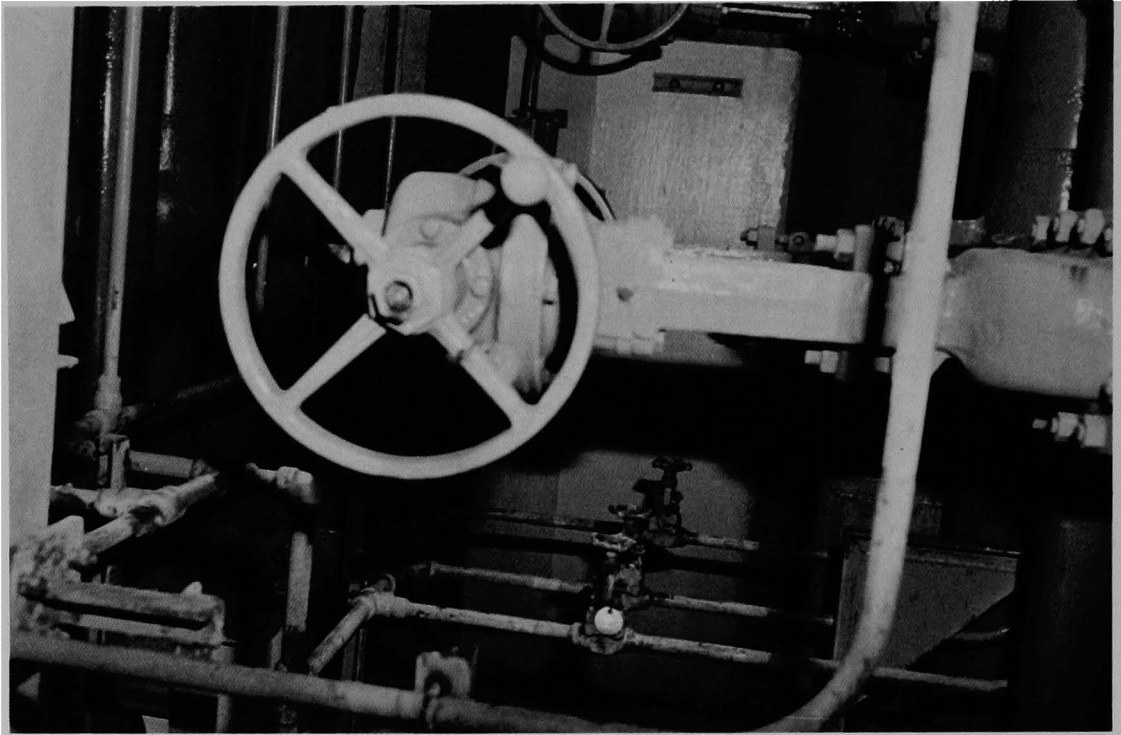

Figure 35 (2A). River water cooling pipes and valves, east end of air cooling assembly.

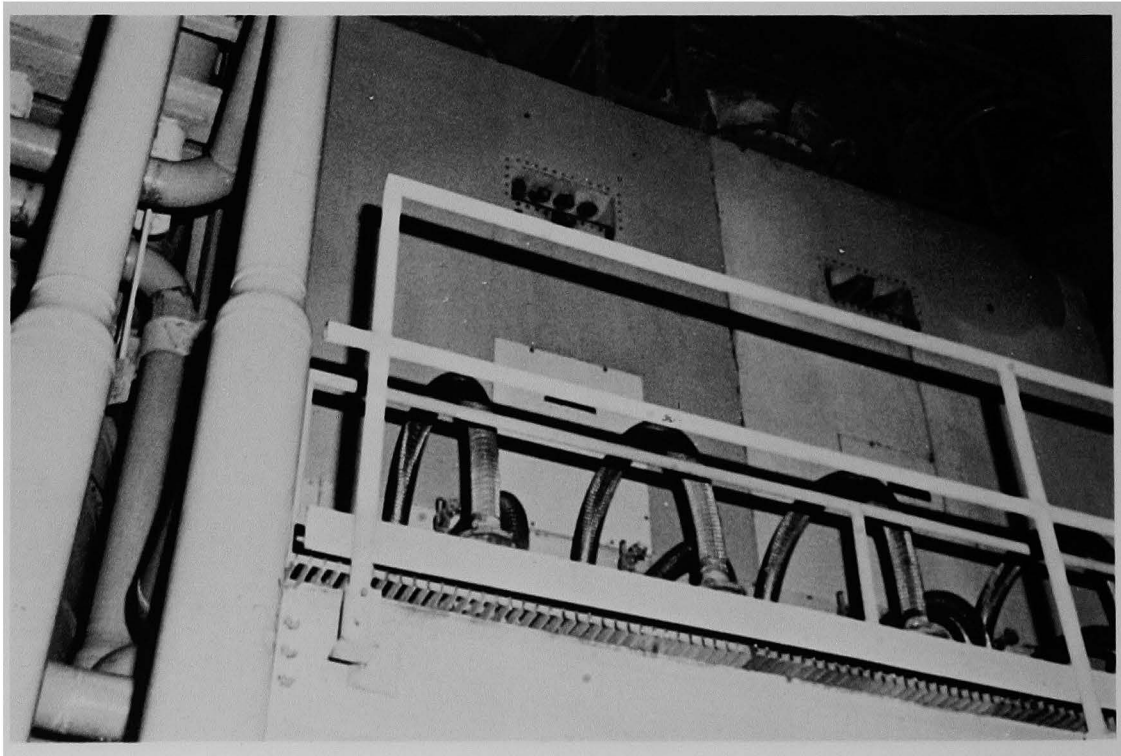

Figure 36 (1A). Upper east end of air cooling assembly.

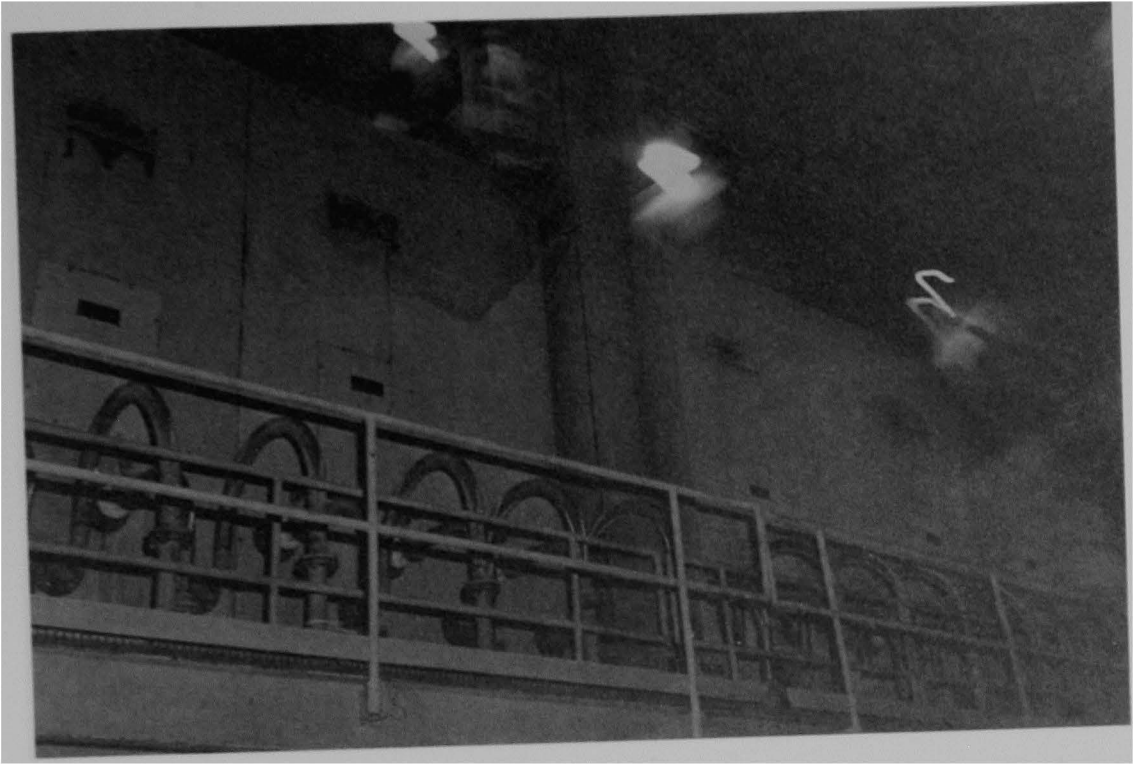

Figure 37 (6A). Upper center portion of air cooling assembly.

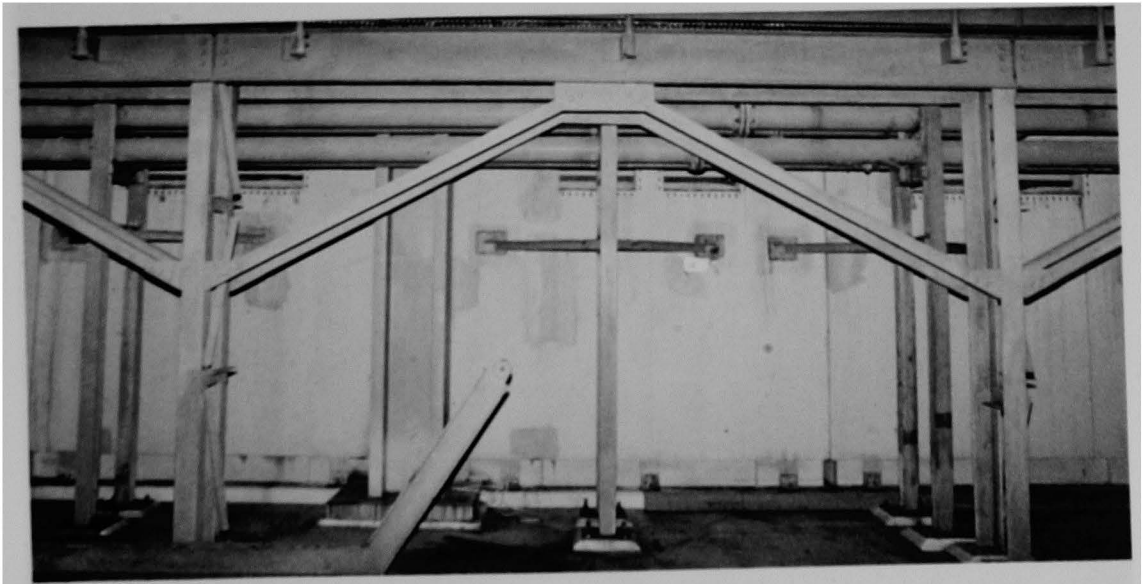

Figure 38 (5C). Center units of air cooling assembly.



Figure 39 (4A). Floor area for decontamination test (black matting in foreground used for beta shielding).



Figure 40 (4A). Floor area for decontamination test, second view.



Figure 41 (1A). Deposition pattern on floor; covered hatch at left.



Figure 42 (1A). Technician in first-entry protective clothing holding teletector; D-ring in background, corner of enclosed elevator/stairwell right edge of photograph.

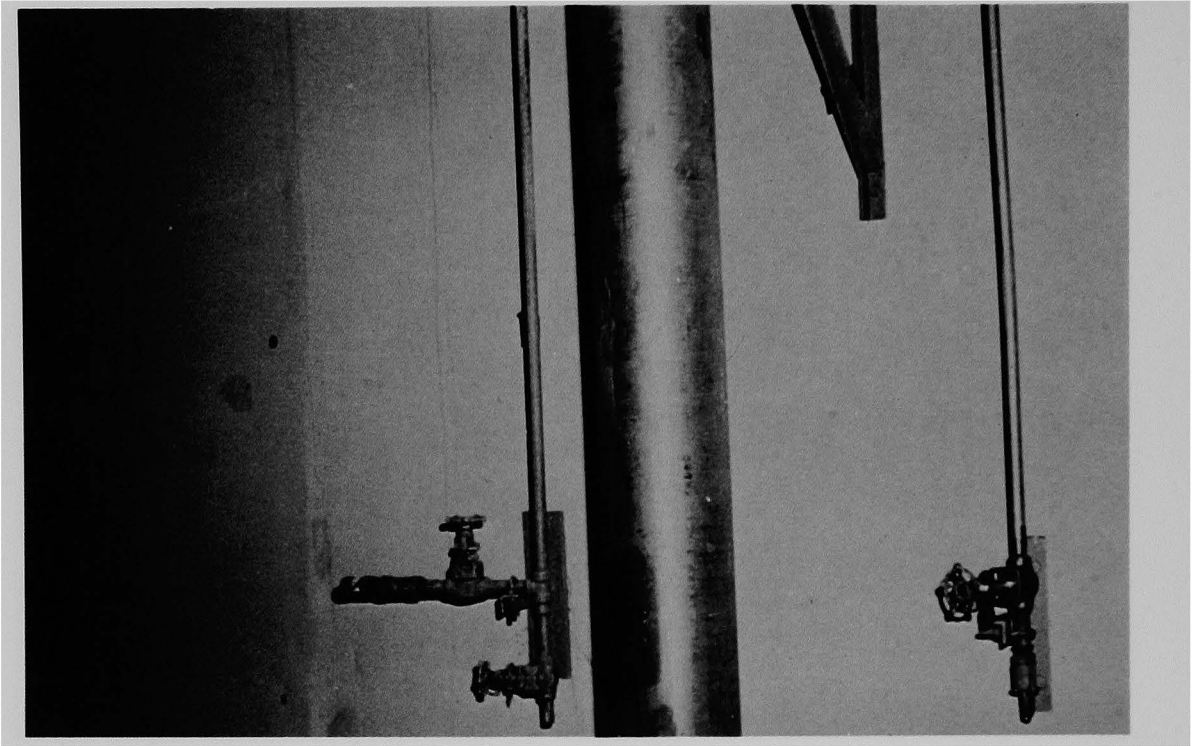

Figure 43 (1A). Pipe on D-ring wall.

ELEVATION 305

QUADRANT 2

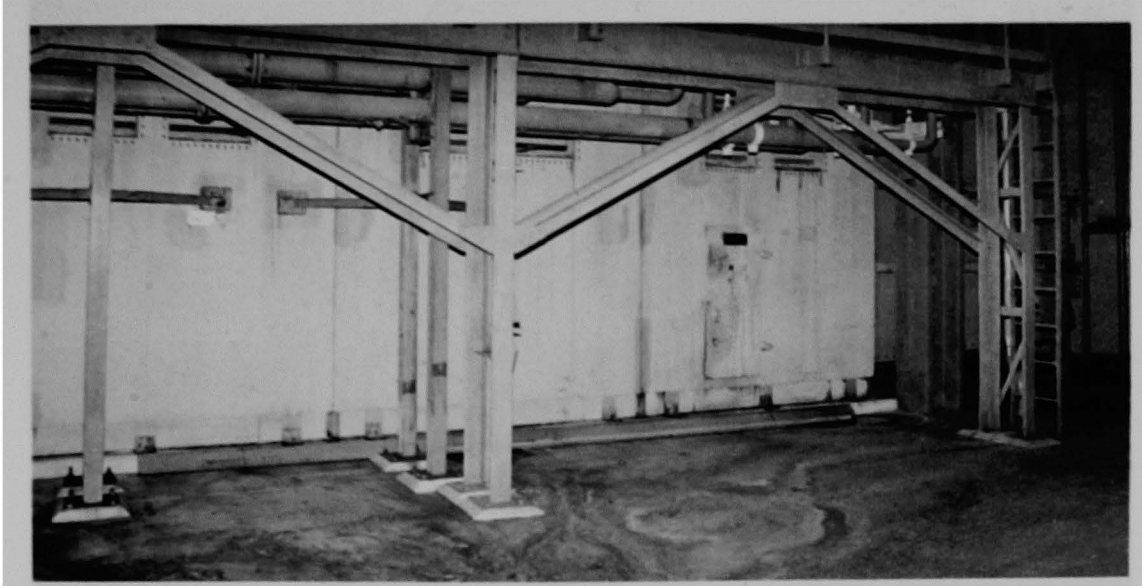

Figure 44 (5C). West units of air cooling assembly.



Figure 45 (6A). West upper end of air cooling assembly.

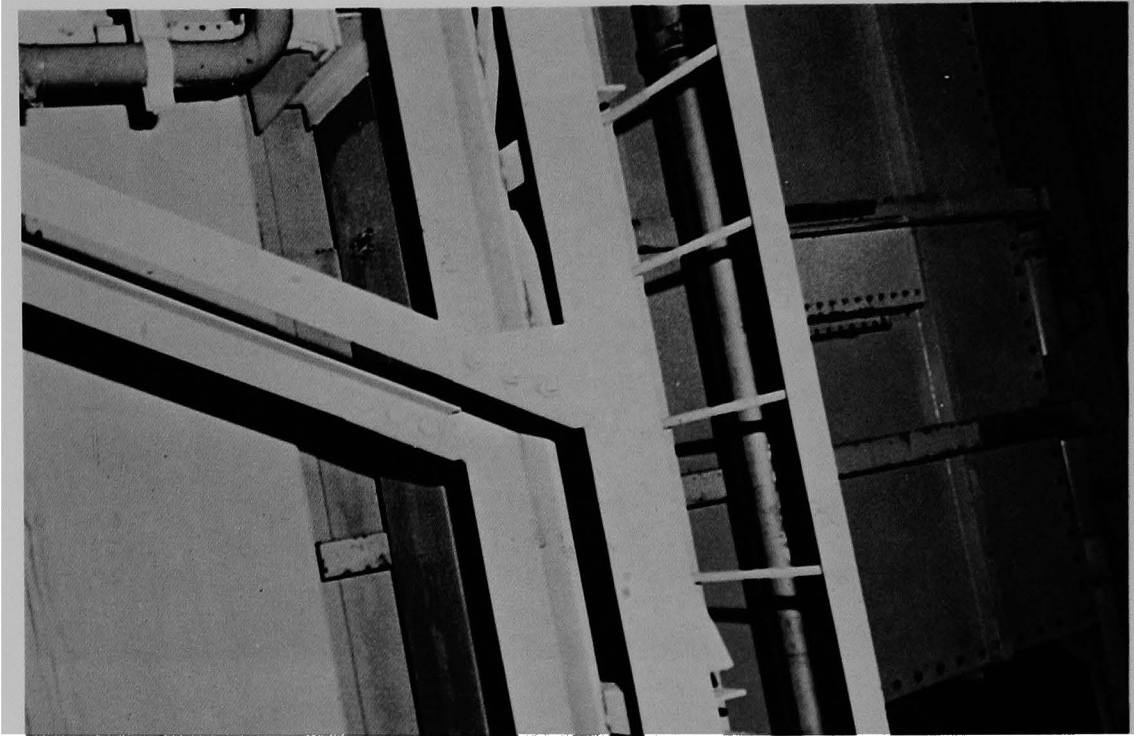

Figure 46 (1A). Brace and ladder at west end of air cooling assembly.

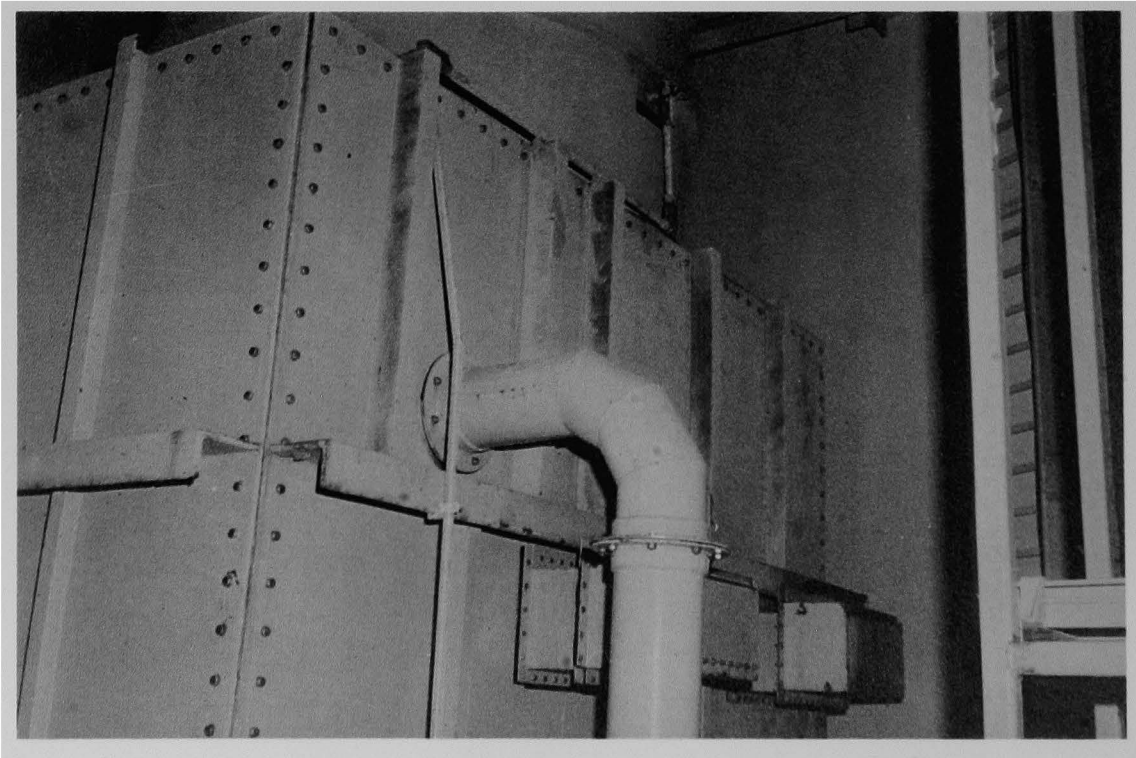

Figure 47 (6A). Plenum at upper west end of air cooling assembly.



Figure 48 (1A). Conduit runs, plenum at west end of air cooling assembly left.

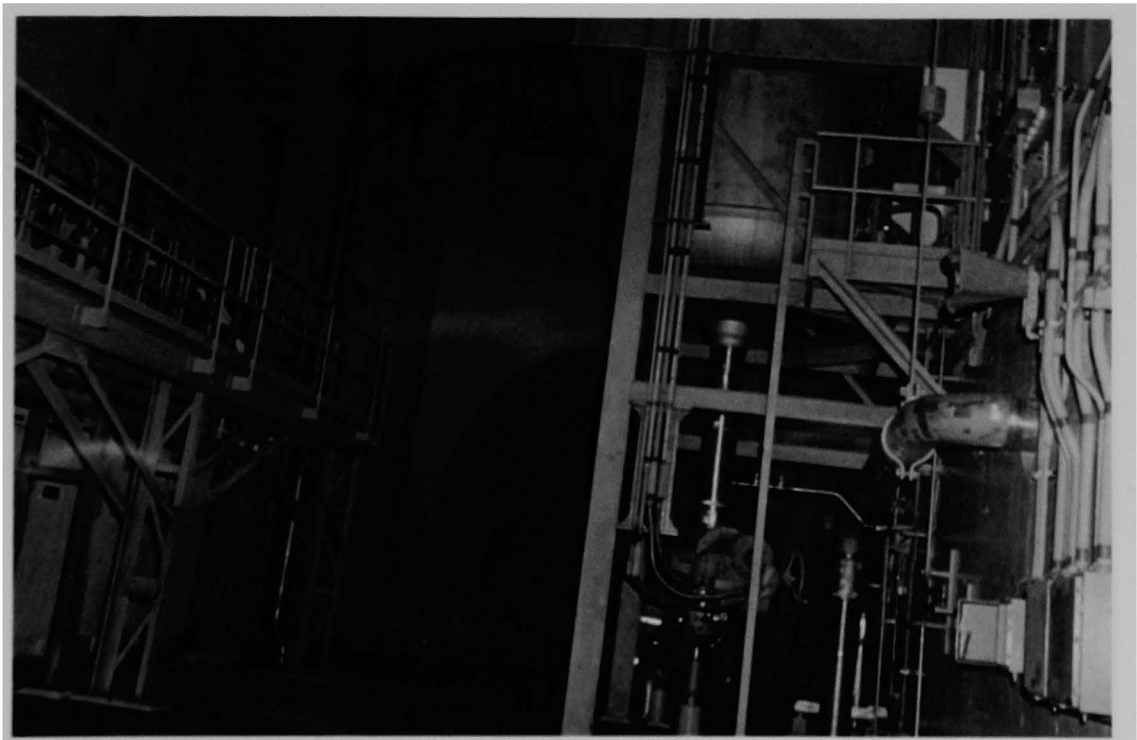

Figure 49 (2A). From left: air coolers, personnel air lock 1 within equipment hatch, core flood tank B, D-ring wall.

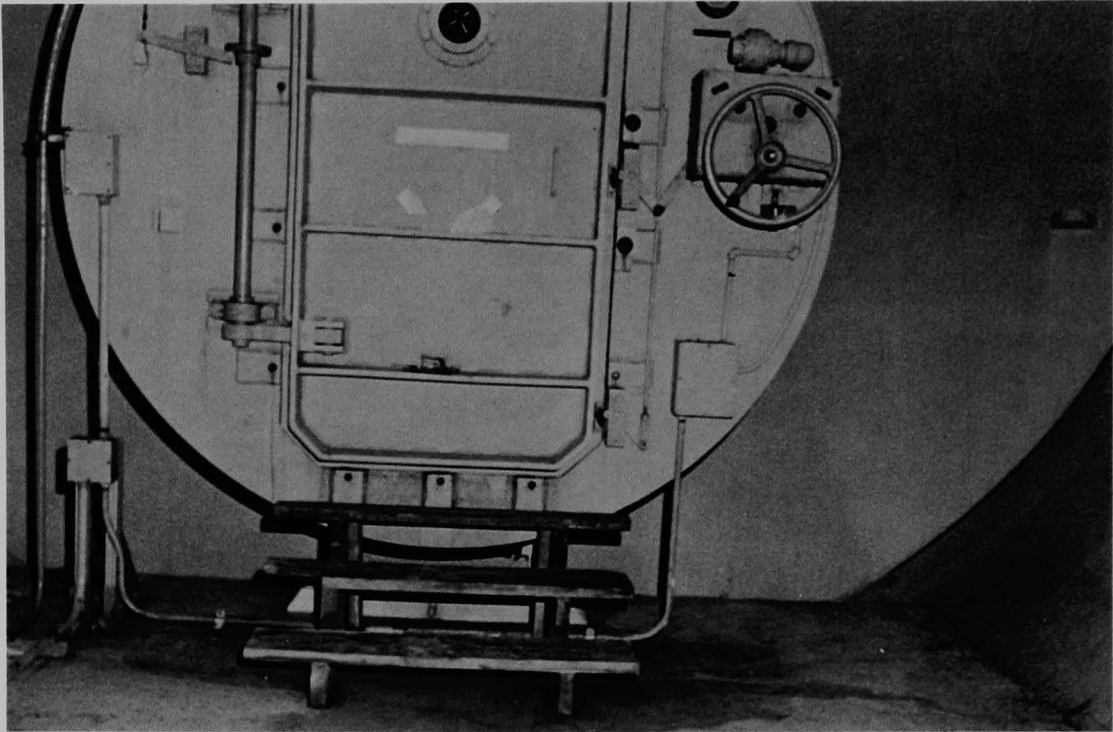

Figure 50 (1A). Personnel air lock 1, within equipment hatch.

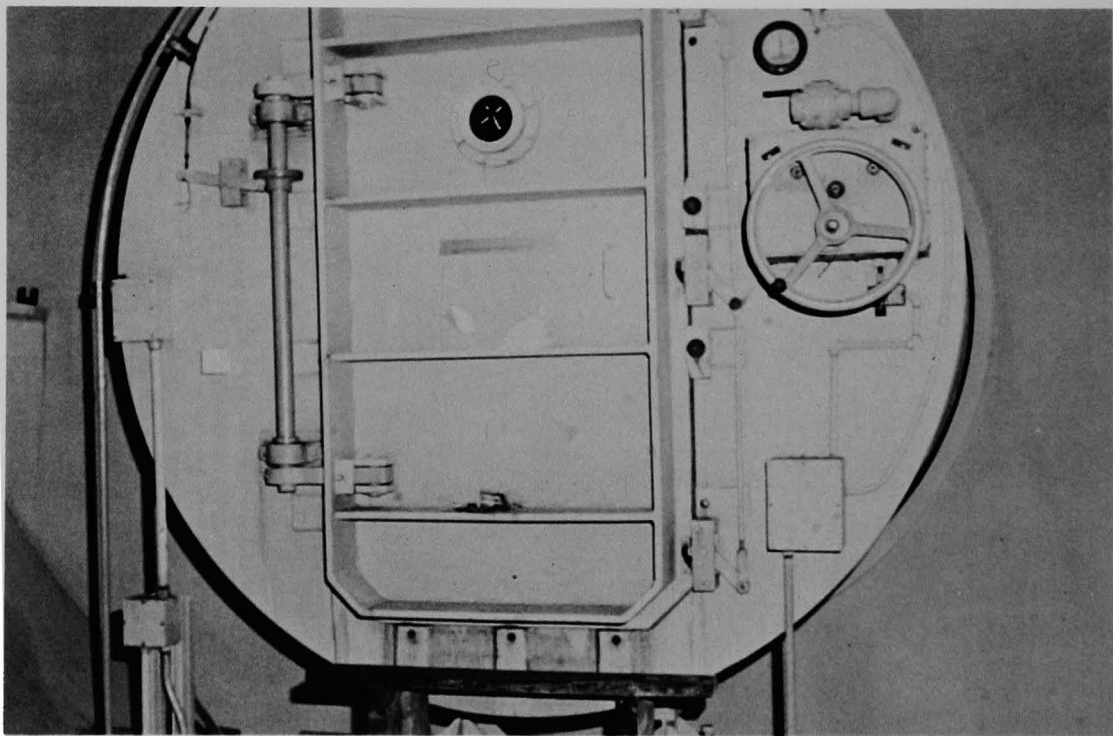

Figure 51 (1A). Door assembly of personnel air lock 1.

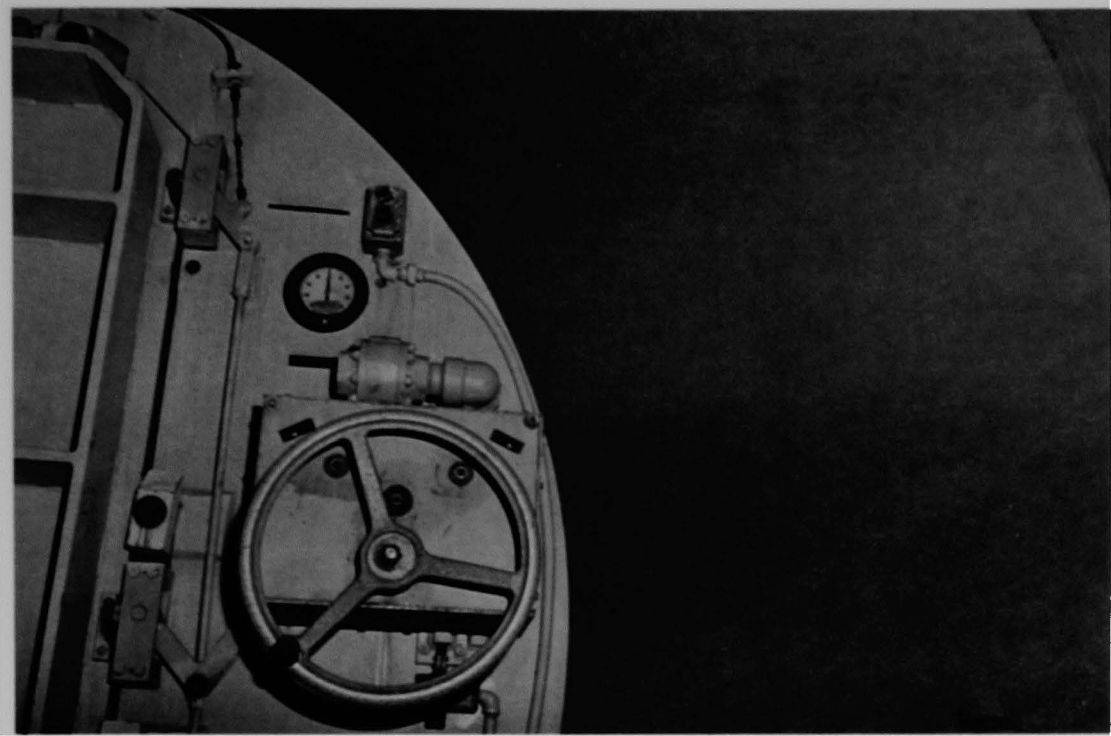

Figure 52 (2A). Handwheel on personnel air lock 1.



Figure 53 (2A). Power panel on I beam; open stairway in background.



Figure 54 (2A). Rusted welding box; Gai-tronic phone in background, open stairway at right.



Figure 55 (1A). Stains on floor at entrance to open stairway.



Figure 56 (1A). Open stairway, HP technician taking radiation surveys.

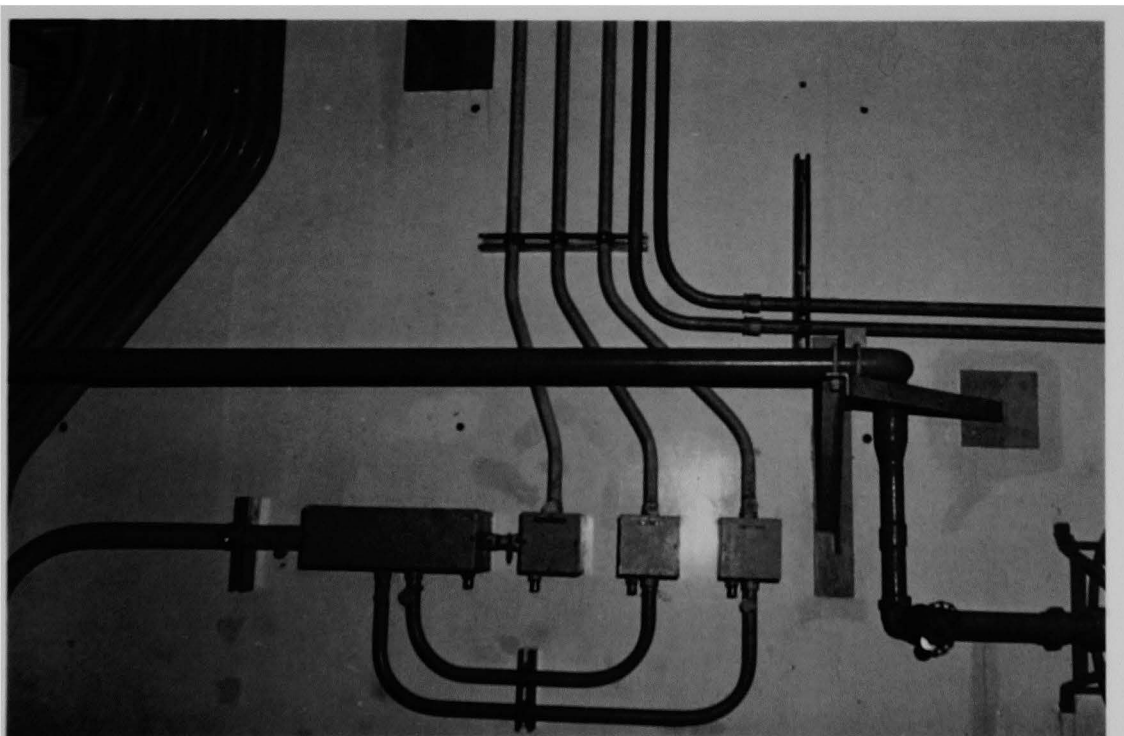

Figure 57 (2A). Seismic instrumentation and fire service station (see Figure 56).



Figure 58 (1A). Broken glass on floor (teletector probe appearing from left corner of photograph).

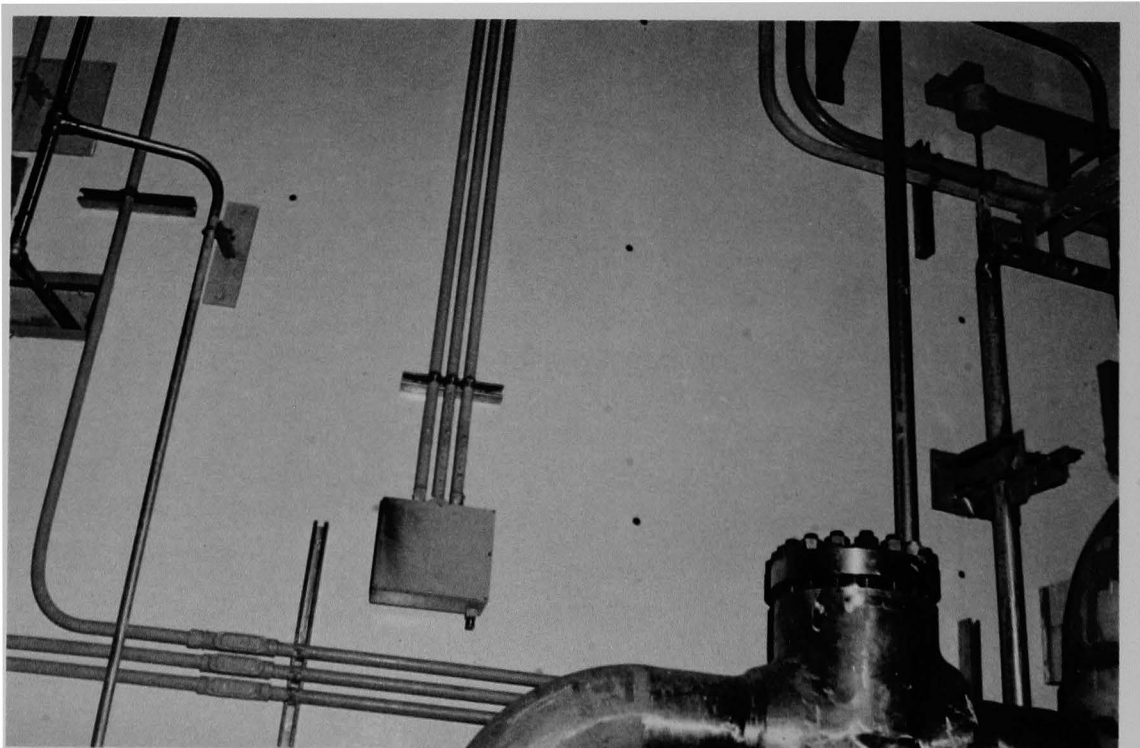

Figure 59 (2A). Circuit box, core flood B check valve, and piping along D-ring wall.

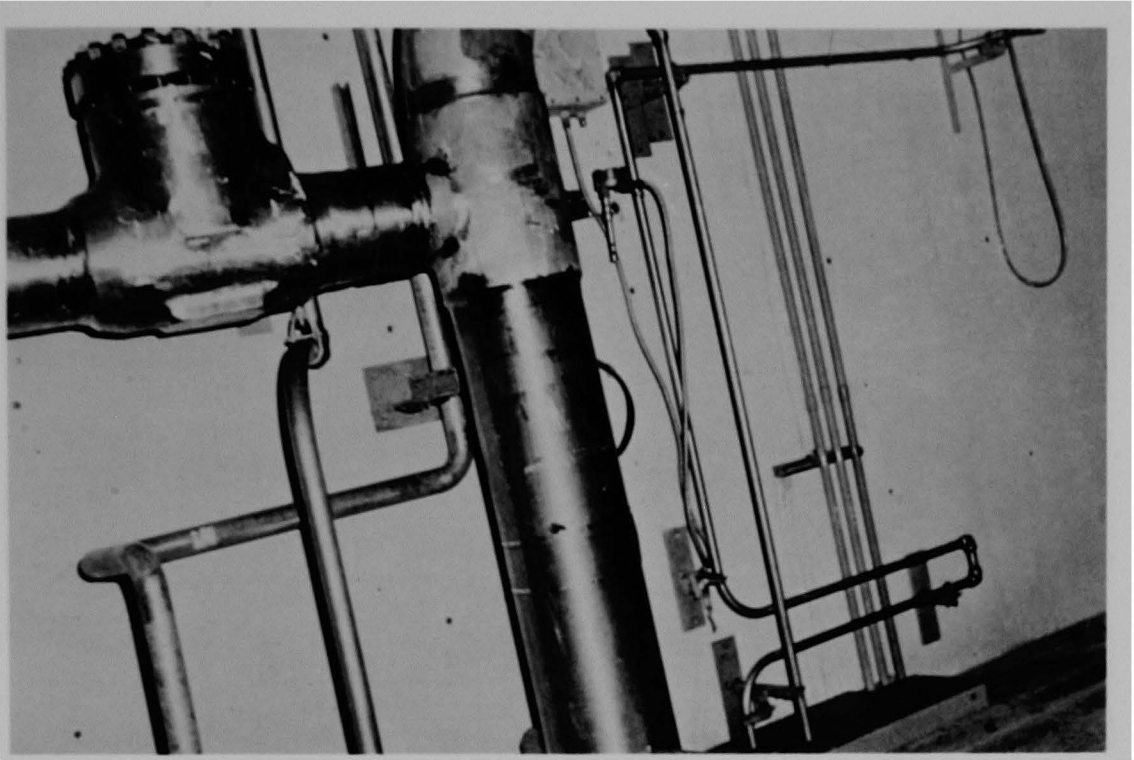

Figure 60 (1A). Core flood tank B piping on seismic support.

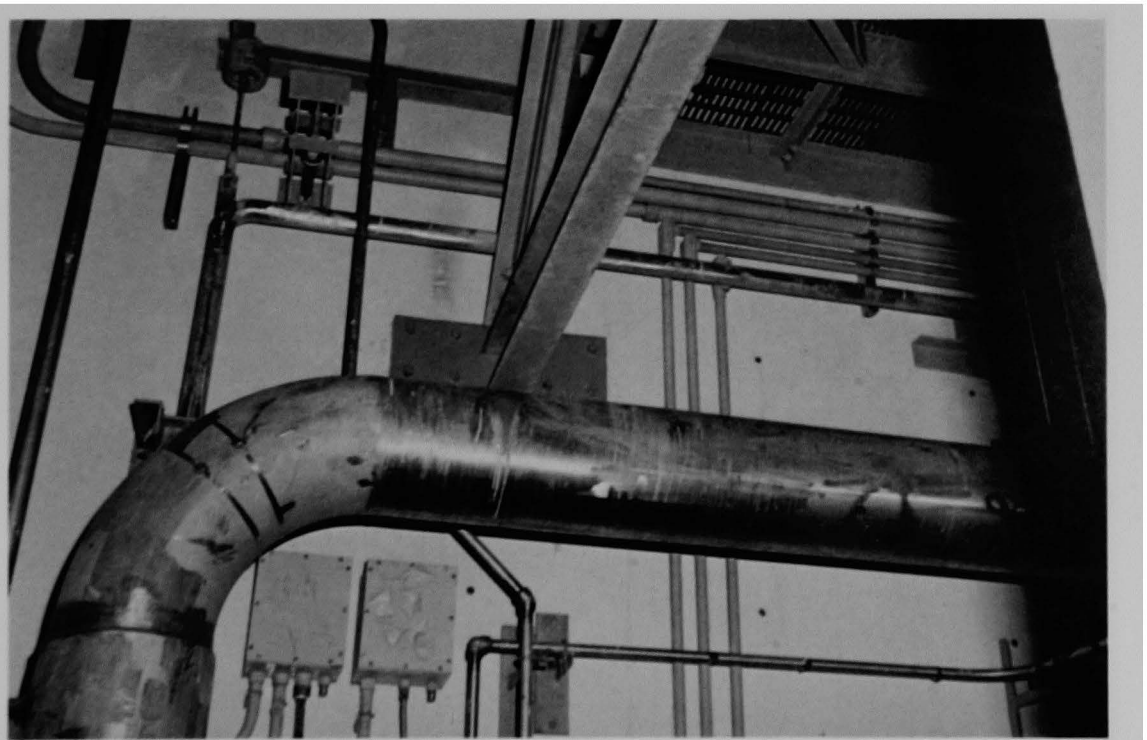

Figure 61 (2A). Core flood tank B piping running under access platform to core flood tank valves.

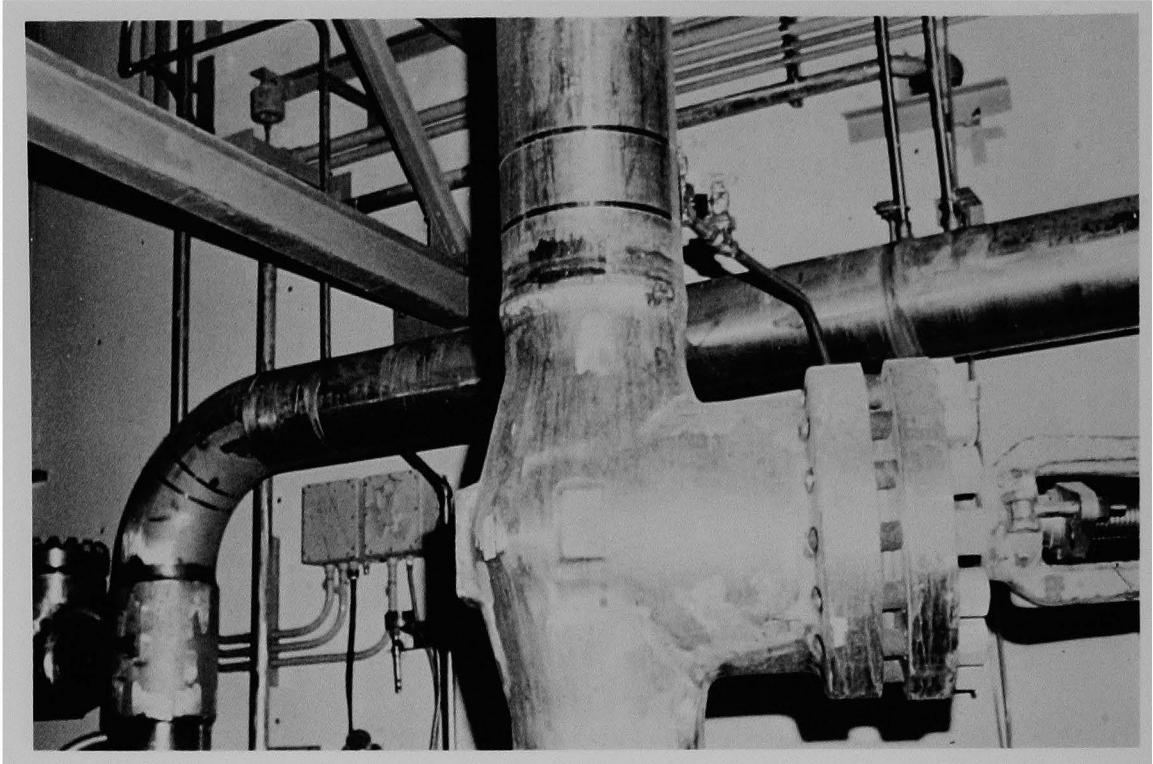

Figure 62 (1A). Check valve directly under core flood tank B.

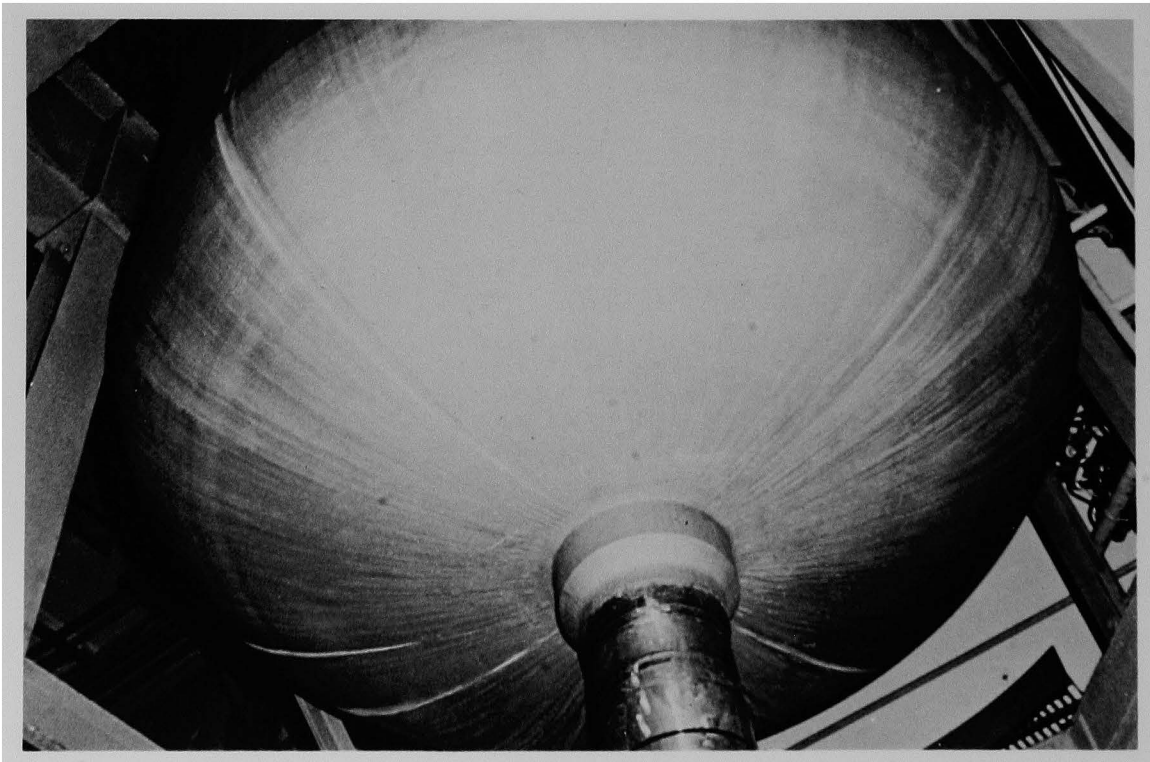

Figure 63 (1A). Bottom view of core flood tank B.

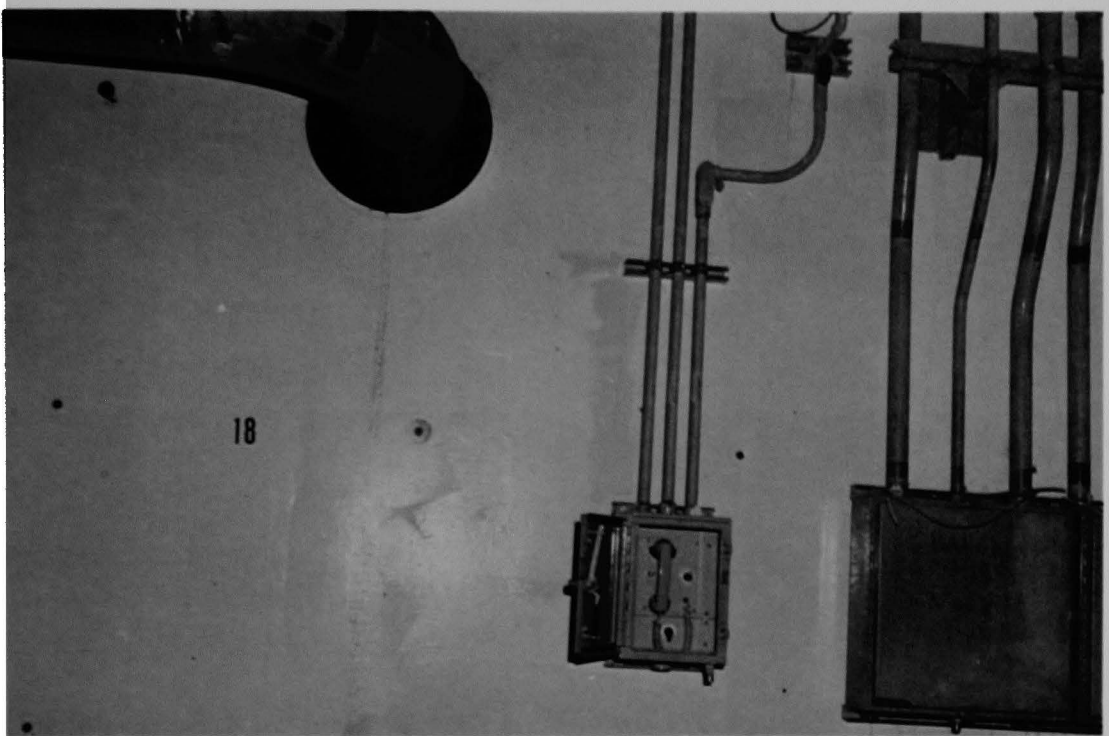

Figure 64 (2A). Core flood tank inlet piping, Gai-tronic telephone, and source range instrumentation panel.

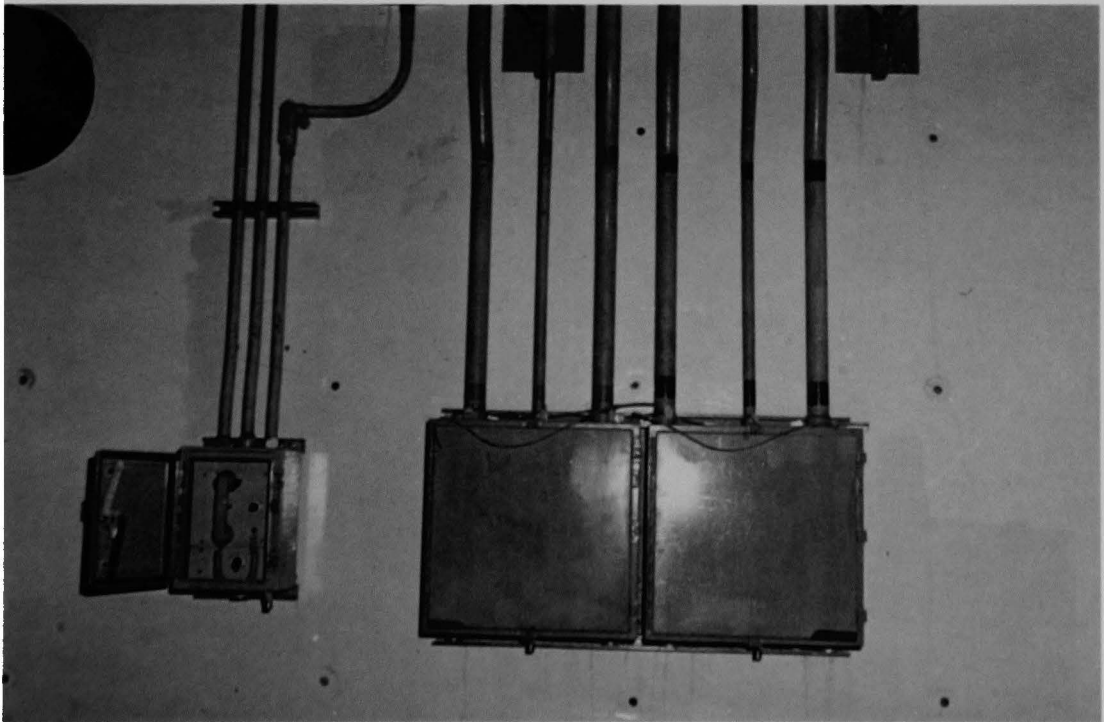

Figure 65 (2A). Gai-tronic telephone and source range instrumentation panel.

ELEVATION 305

QUADRANT 3



Figure 66 (1A). View up open stairway.



Figure 67 (2A). Steep-angle view down open stairway to water in basement. Note that the water level appears to be 1 to 2 inches above the lower landing.



Figure 68 (2A). View down open stairway to water in basement. Note that the water appears to be 1 to 2 inches above the lower landing.



Figure 69 (2A). Northeast view through open stairway to D-ring, HP technician taking radiation survey.



Figure 70 (2A). South view to open stairway, HP technician taking radiation survey.



Figure 71 (5A). Northeast view taken north of open stairway; wall shielding incore instrumentation cable chase in background.

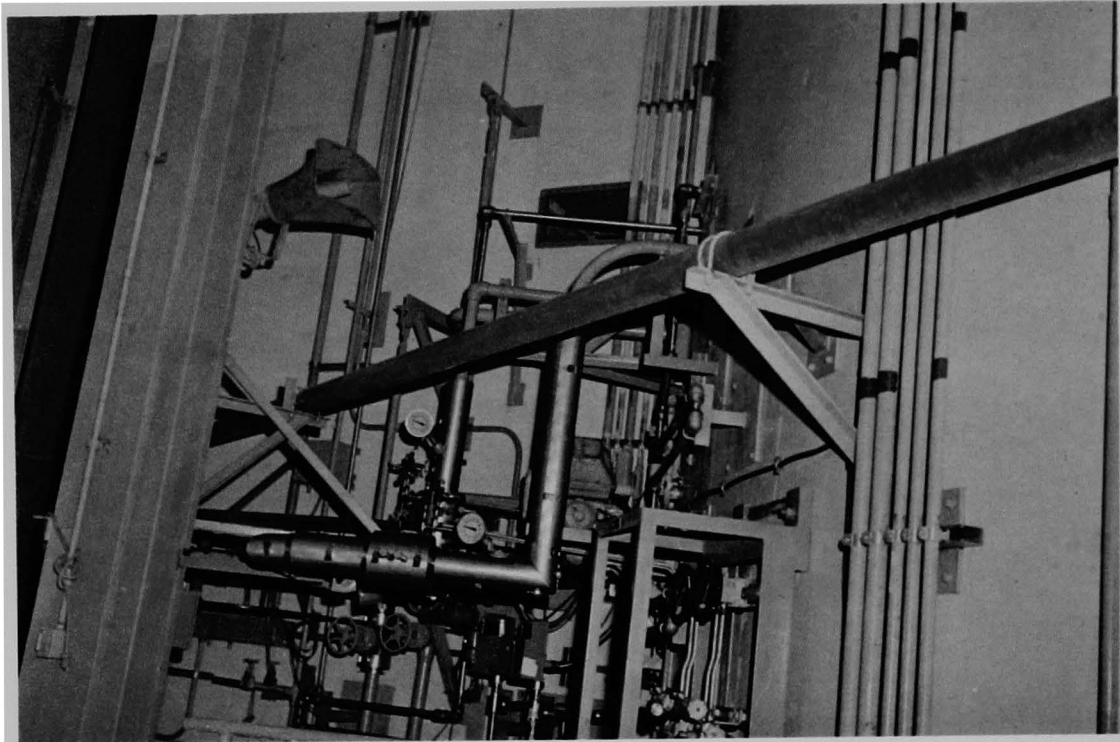

Figure 72 (2A). Miscellaneous valves and pipes at the northwest corner of the D-ring.

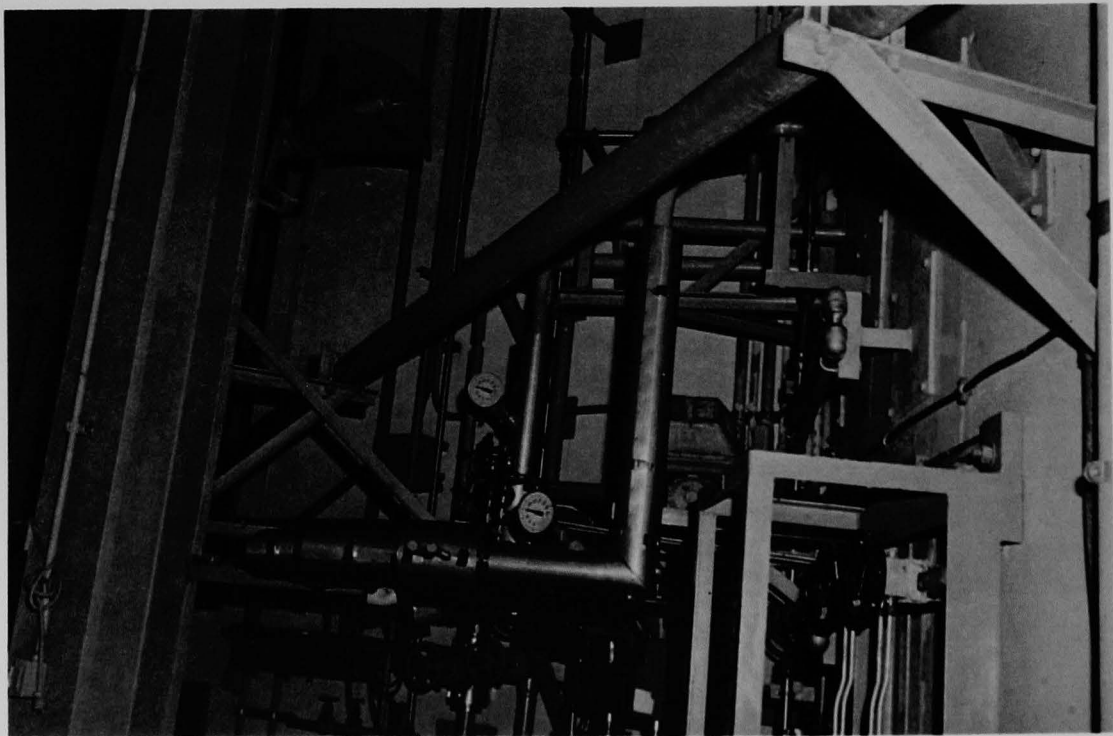

Figure 73 (2A). Closer view of valves and pipes at the northwest corner of the D-ring.

ELEVATION 305

QUADRANT 4



Figure 74 (1A). General view of flow area within quadrant 4 north of personnel airlock 2.

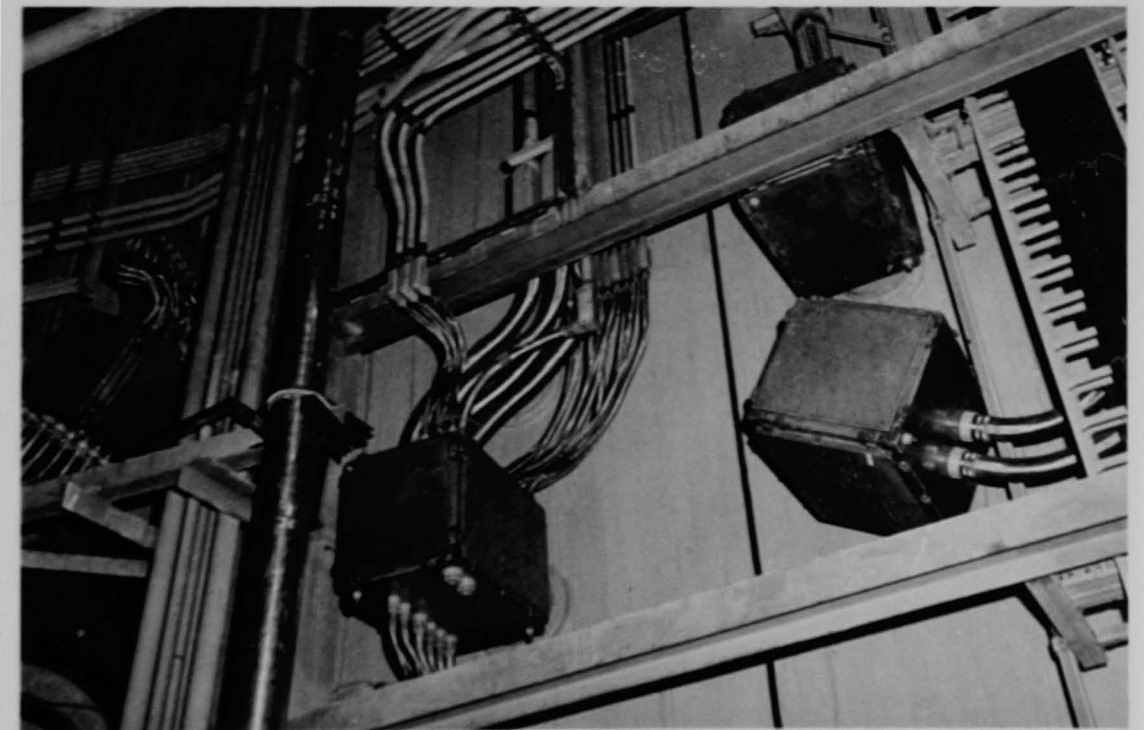

Figure 75 (5A). Electrical penetrations on containment liner; R-504 top, R-505 left, R-507 center right.

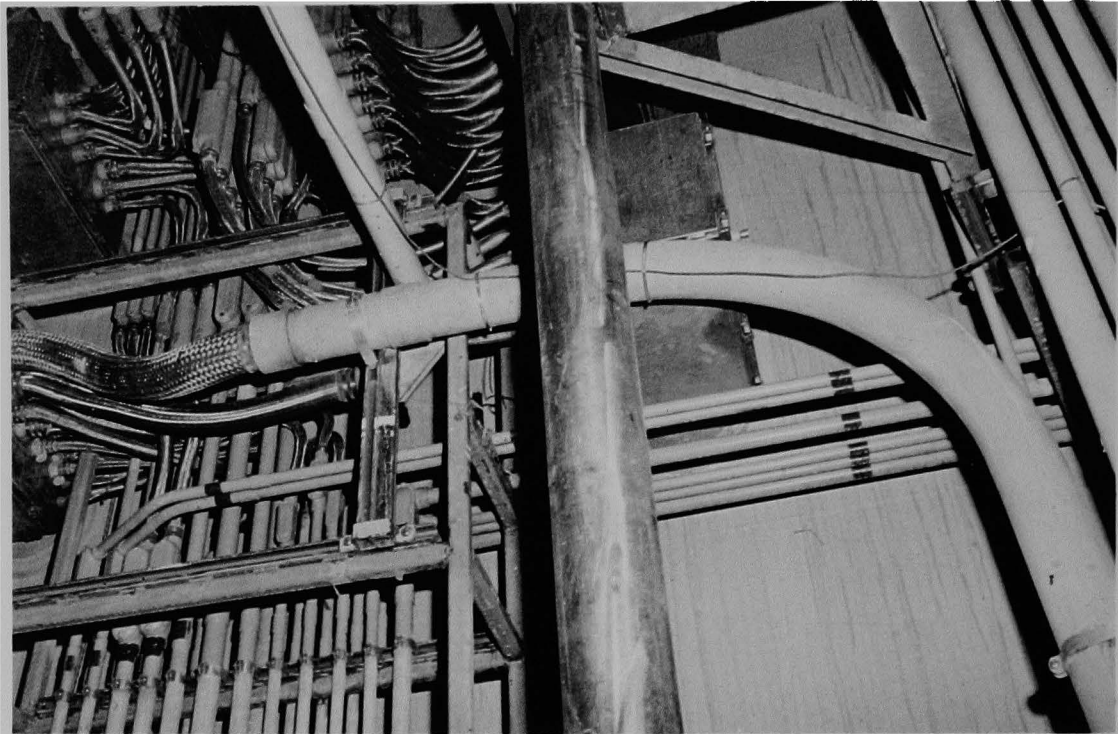

Figure 76 (5A). Electrical penetrations on containment liner (continuation to the left and lower of Figure 75).

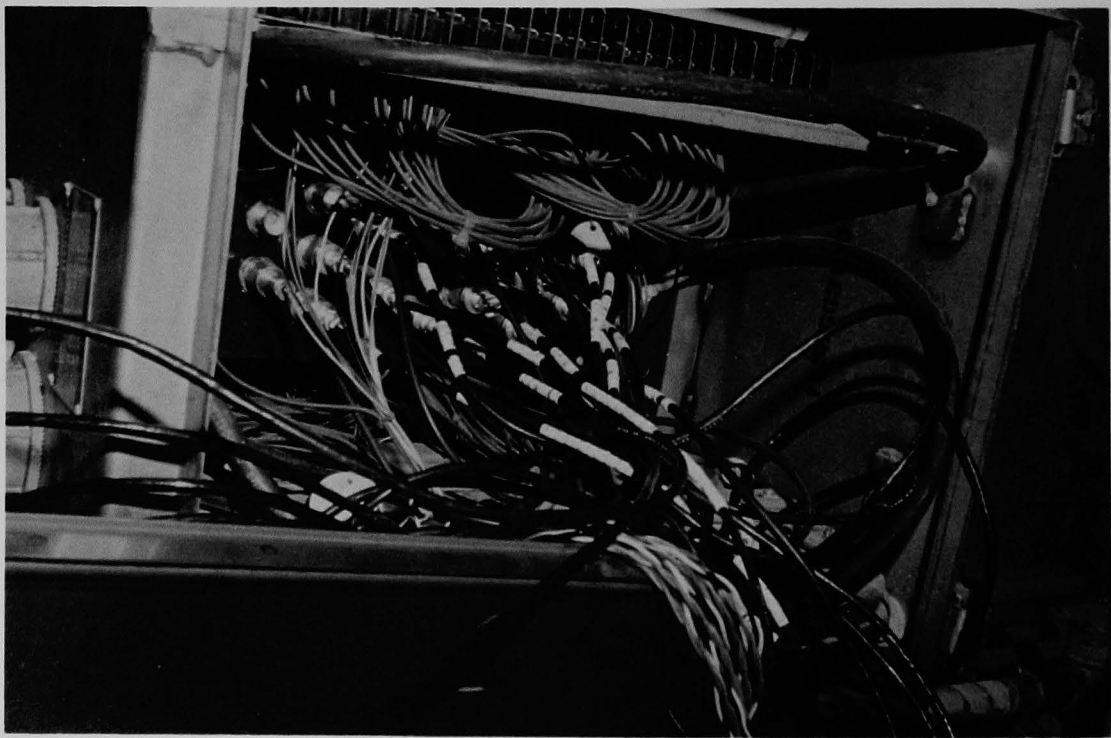

Figure 77 (6A). Frontside of electrical penetration R-507 on containment liner (photograph taken from scaffolding erected under the penetration).



Figure 78 (6A). Right frontside of electrical penetration R-507 (cf. Figure 77).



Figure 79 (6A). View of electrical penetration R-507 from above (cf. Figure 77).

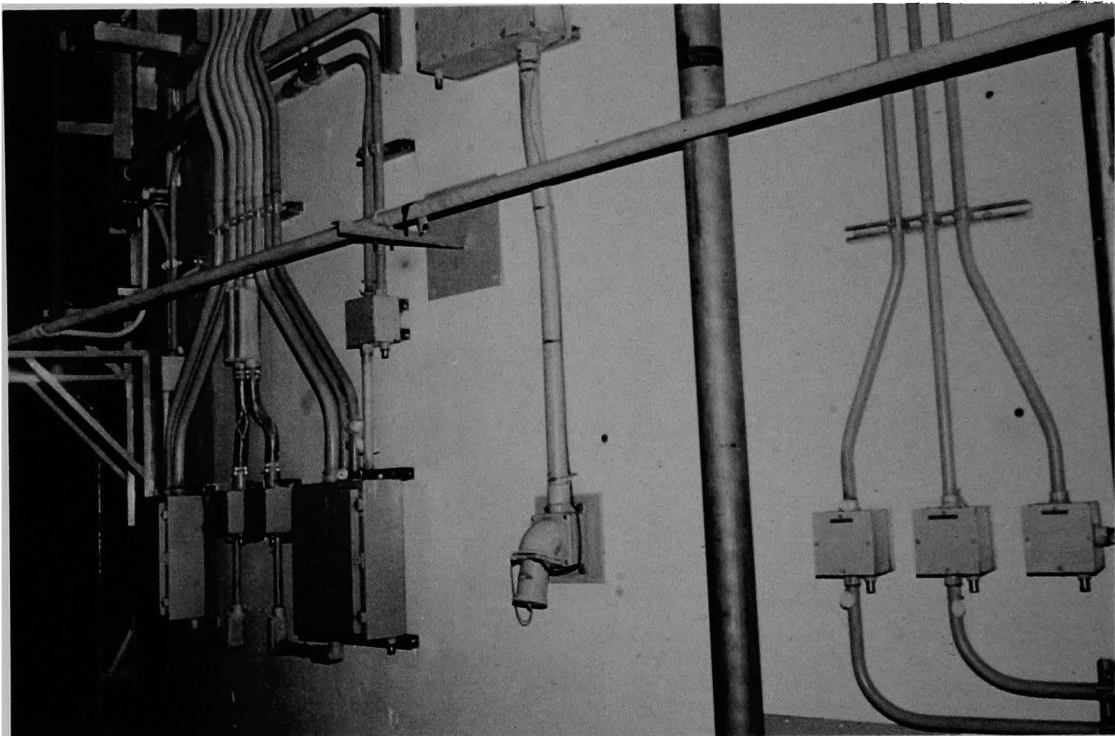

Figure 80 (2B). East side of D-ring wall, four vibration instrumentation panels at right.



Figure 81 (6A). Floor penetrations 210, 211 and 211 on east side of D-ring wall.



Figure 82 (6A). Floor penetrations 211 and 212 (cf. Figure 81).

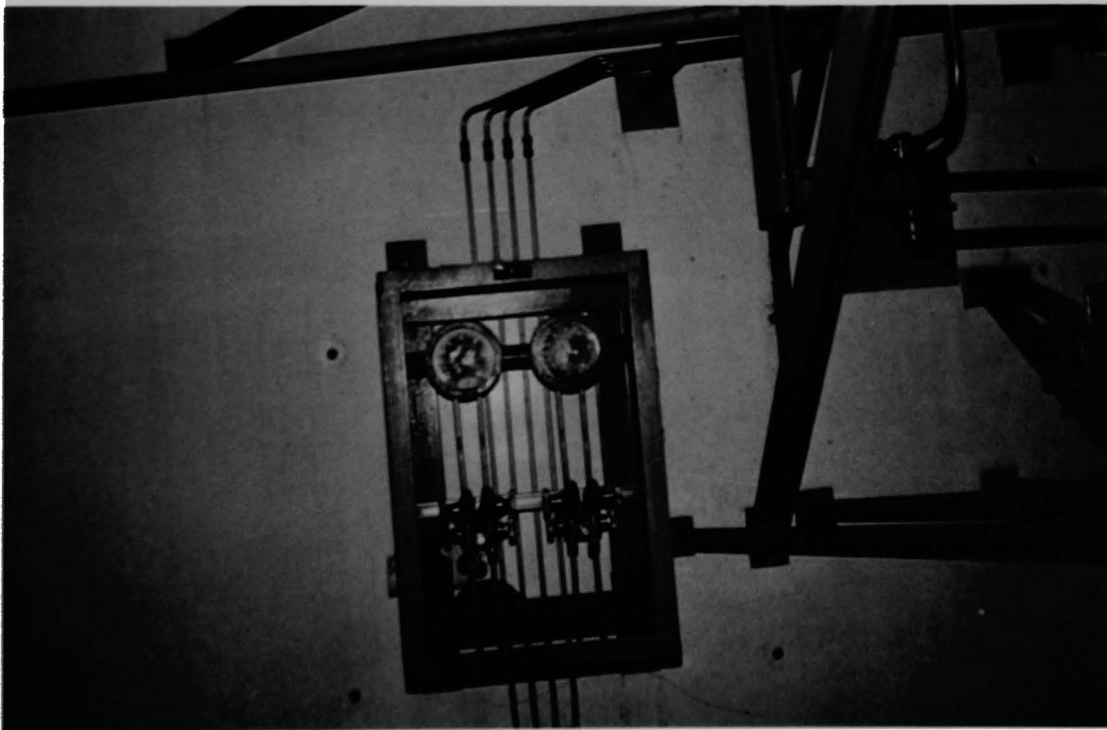

Figure 83 (2B). Gauges and instrumentation along northeast side of D-ring.

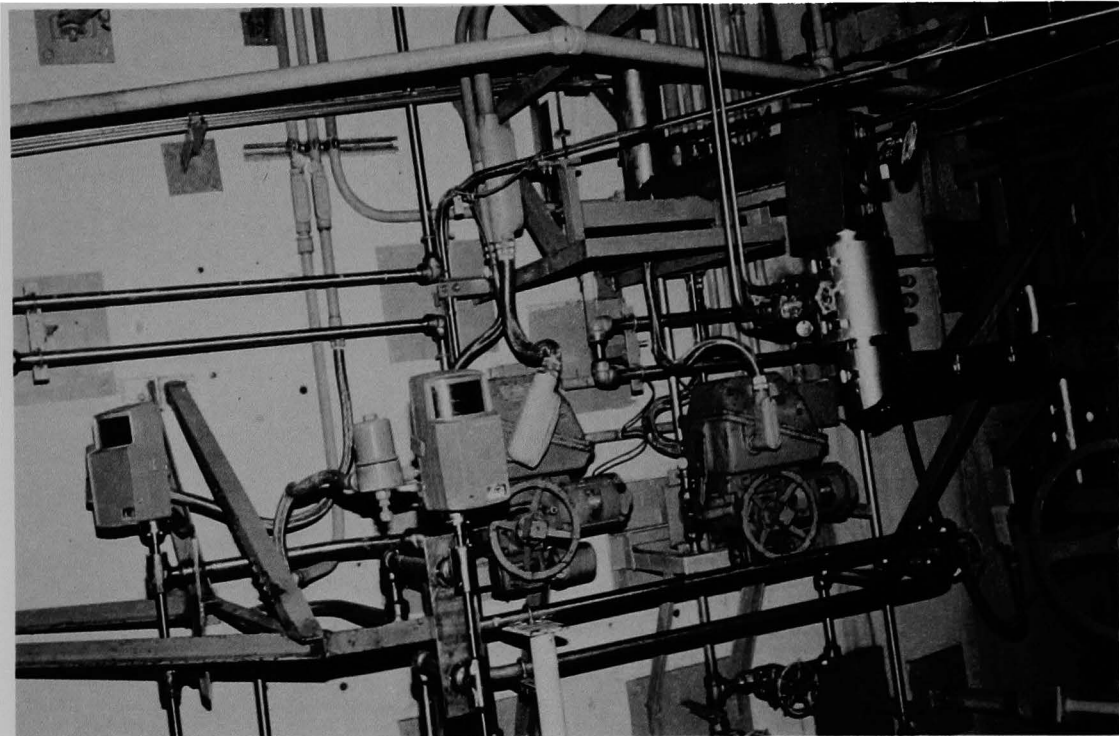

Figure 84 (2B). Northeast side of D-ring near core flood tank A.



Figure 85 (6A). View north from scaffolding erected at overhead piping, near core flood tank A.



Figure 86 (6A). View up to the overhead piping, grating, and cables near core flood tank A.

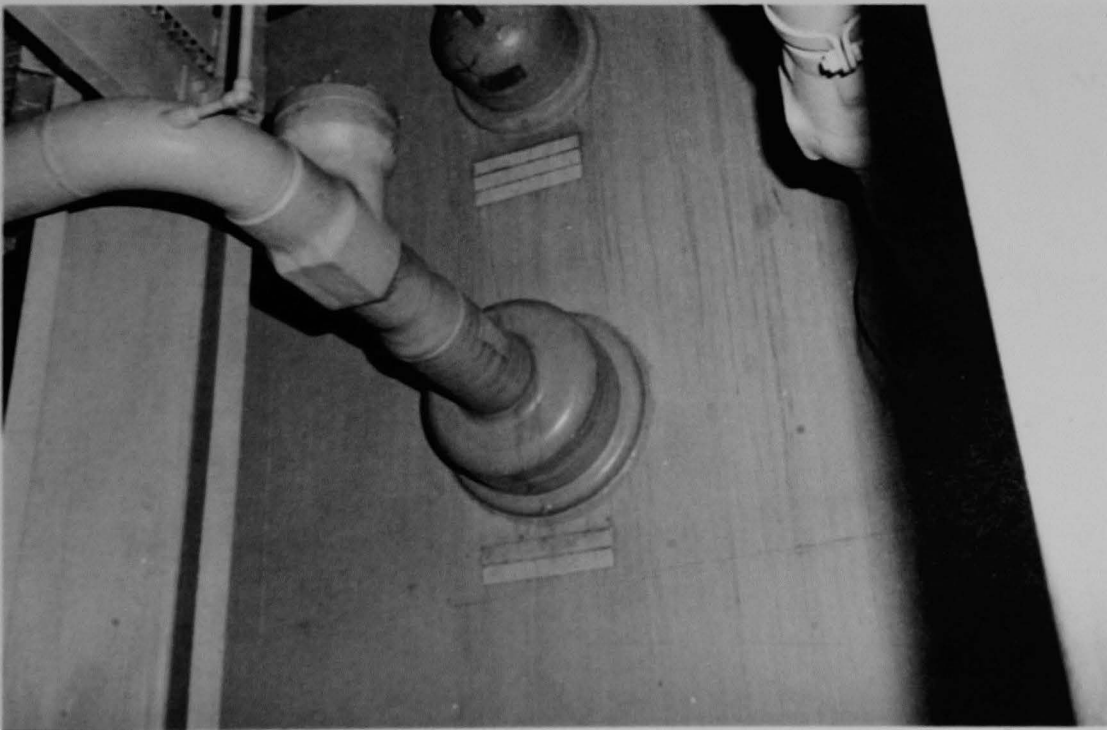

Figure 87 (5A). Mechanical penetrations R-563 and R-567 on the containment wall.

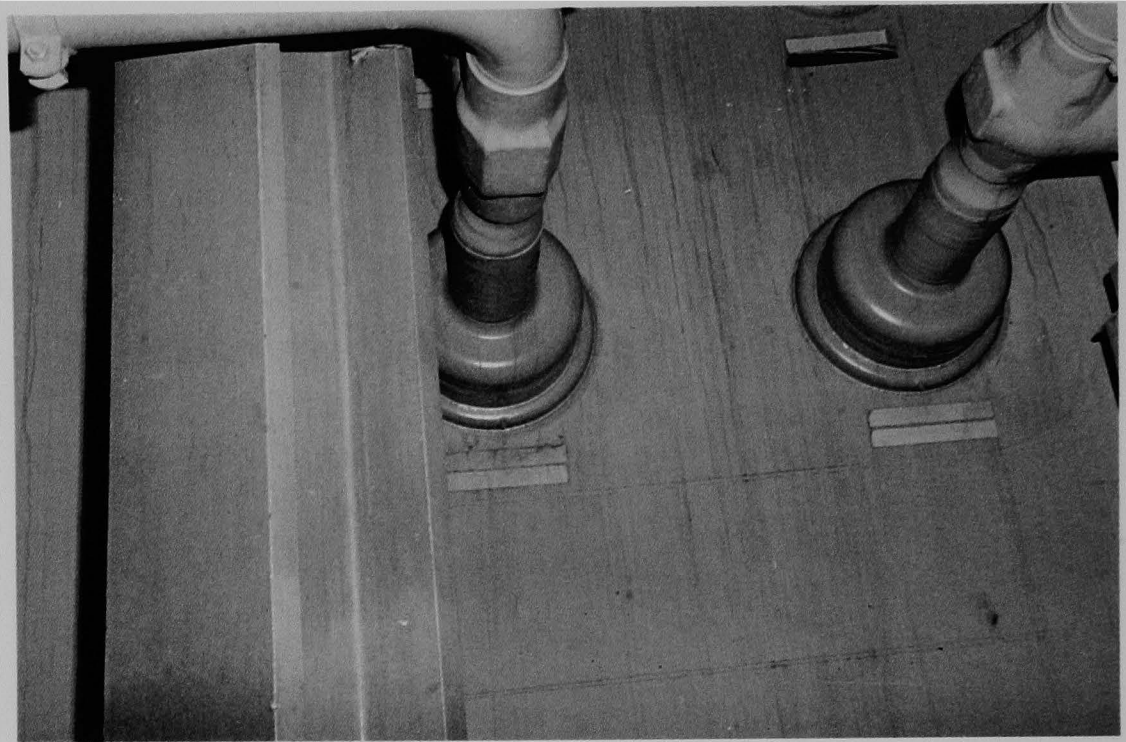

Figure 88 (5A). Mechanical penetrations R-563 and R-567, second view.

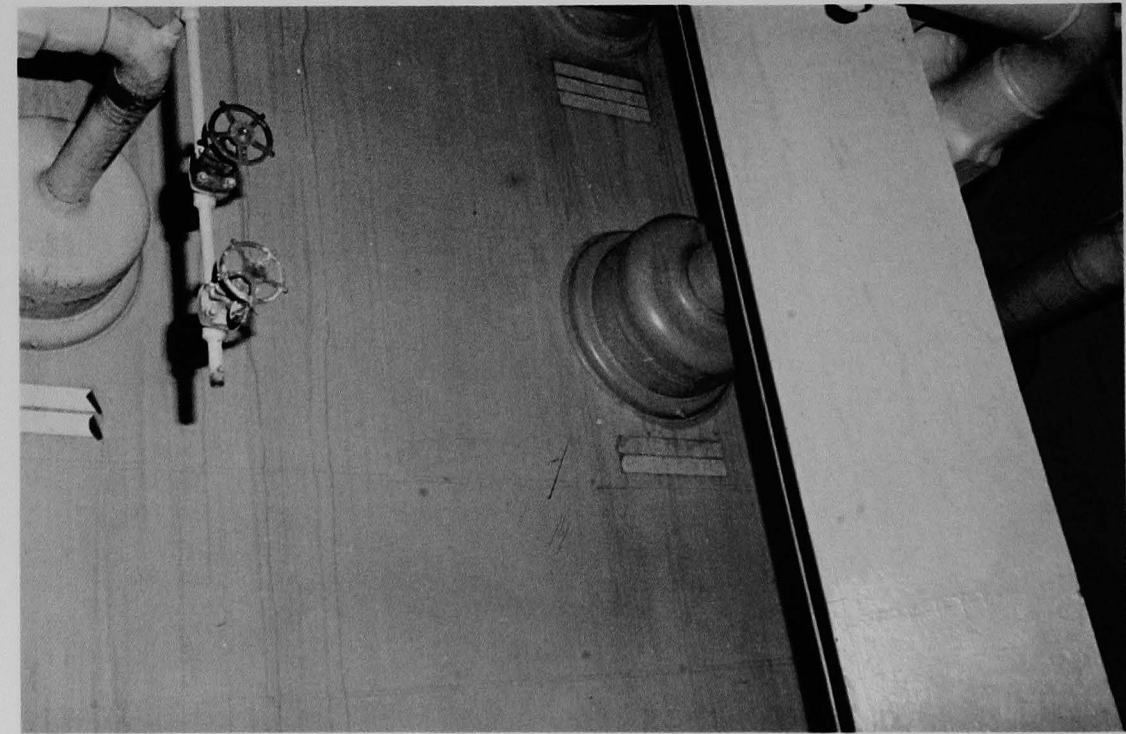

Figure 89 (5A). Mechanical penetrations on the containment wall; R-562, top center; R-559, R-563, and R-567 (left to right).

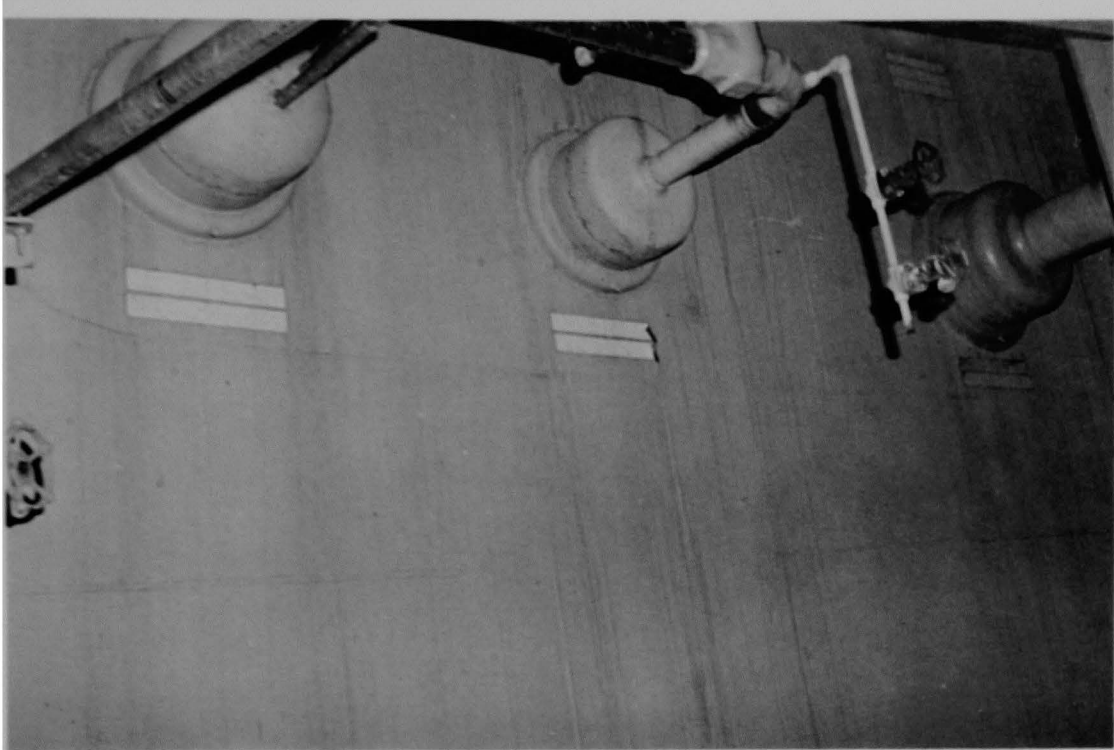

Figure 90 (5A). Mechanical penetrations on the containment wall; from left to right, R-555, R-559, and R-563.

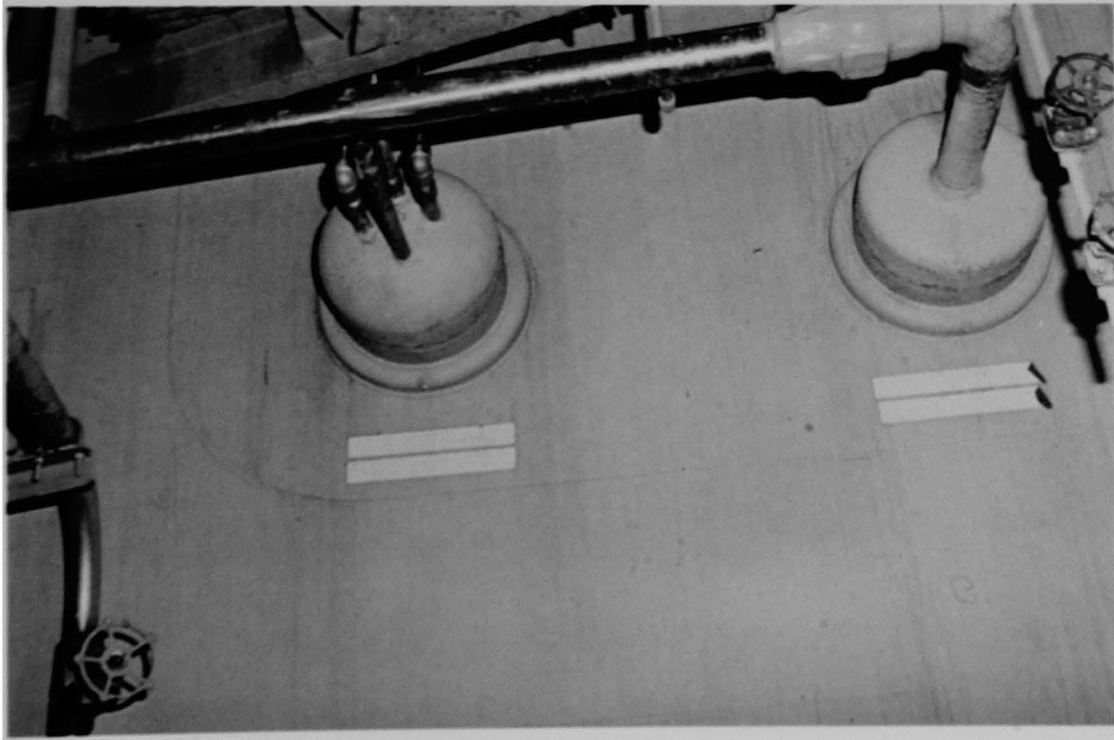

Figure 91 (5A). Mechanical penetrations R-555 and R-559 on the containment wall.

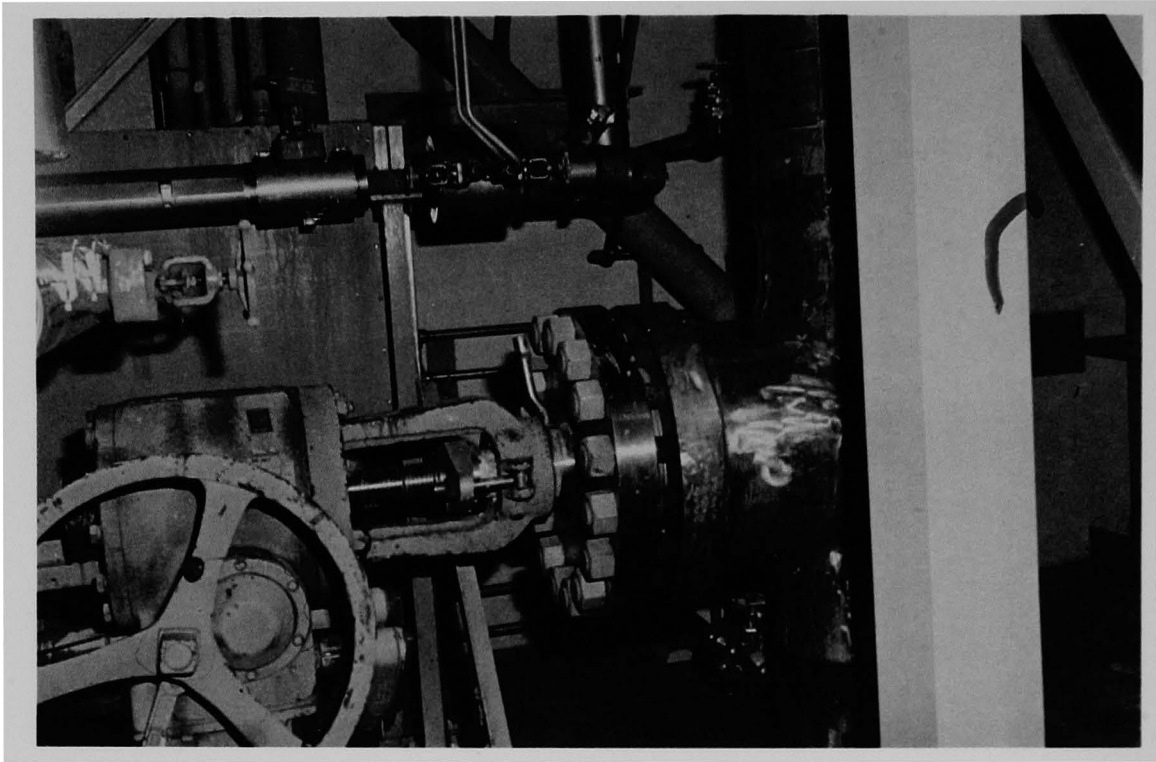

Figure 92 (6A). Stainless steel piping and valve under core flood tank A.

ELEVATION 347
QUADRANT 1



Figure 93 (2A). Ascent up the enclosed stairway.



Figure 94 (2A). Ascent continued up the enclosed stairway.

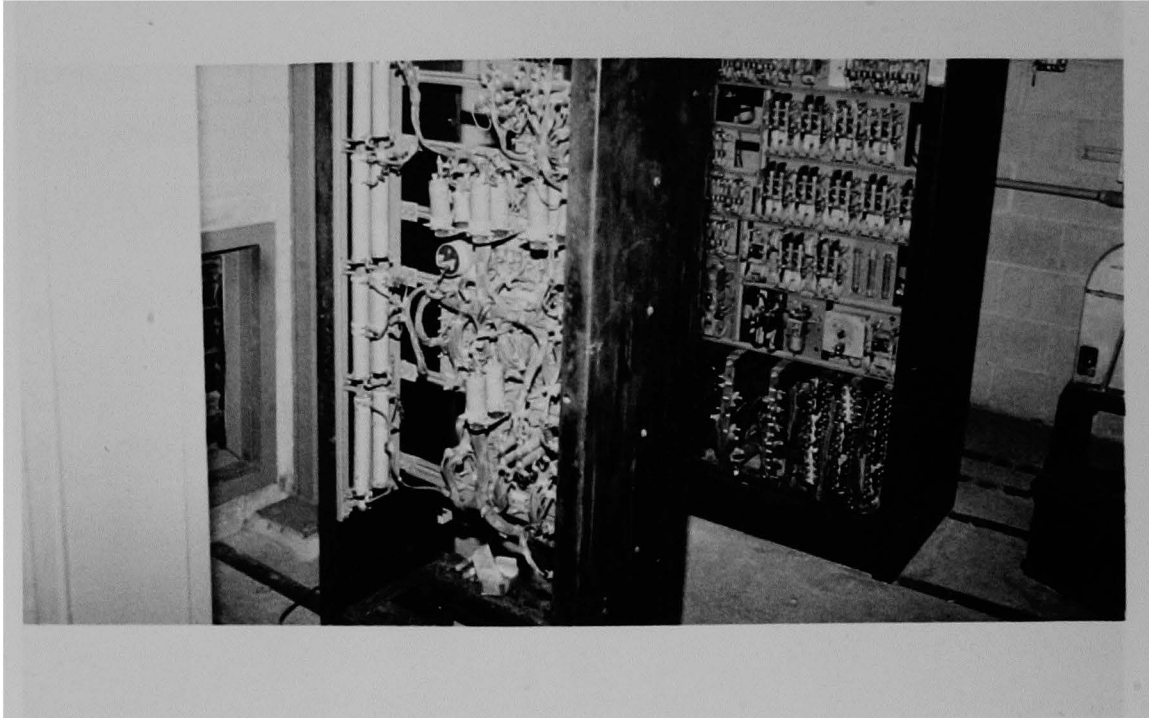

Figure 95 (5C). Elevator and motor room at the top of the stairs inside the enclosed stairwell.

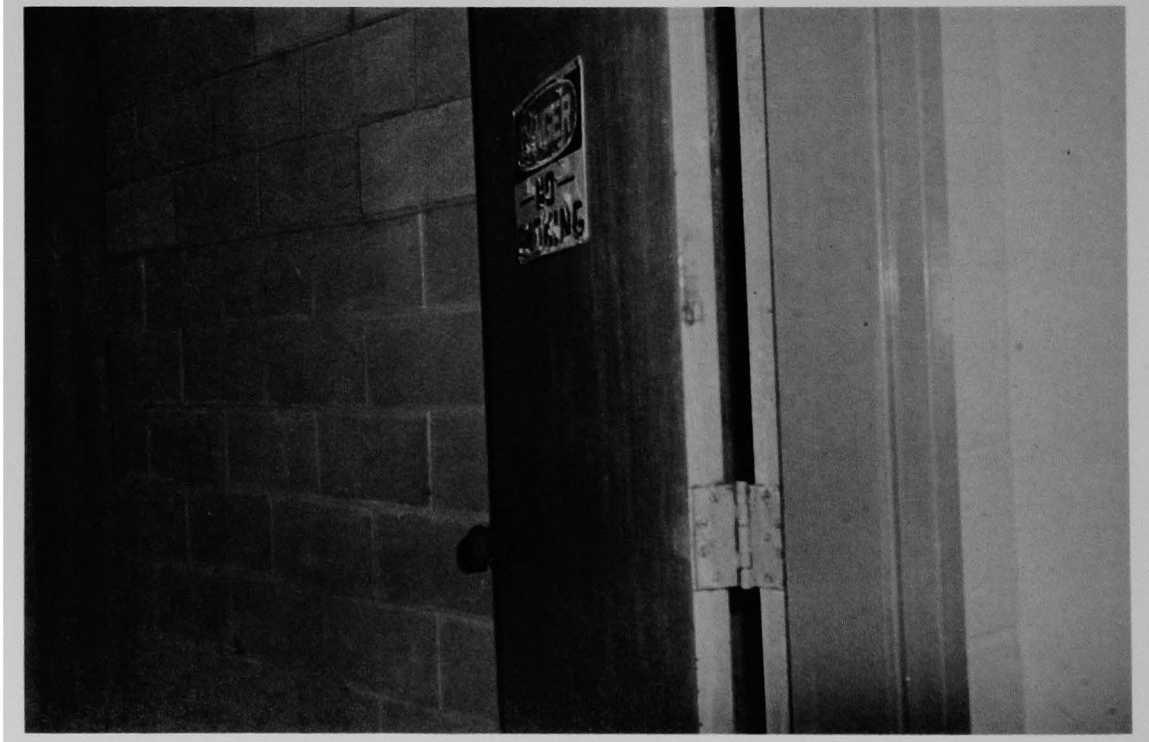

Figure 96 (2A). Door to enclosed stairwell, elevation 347 (closed before entry).



Figure 97 (2B). General view across operating deck to enclosed stairwell; CRDM cable trays left, indexing fixture right.

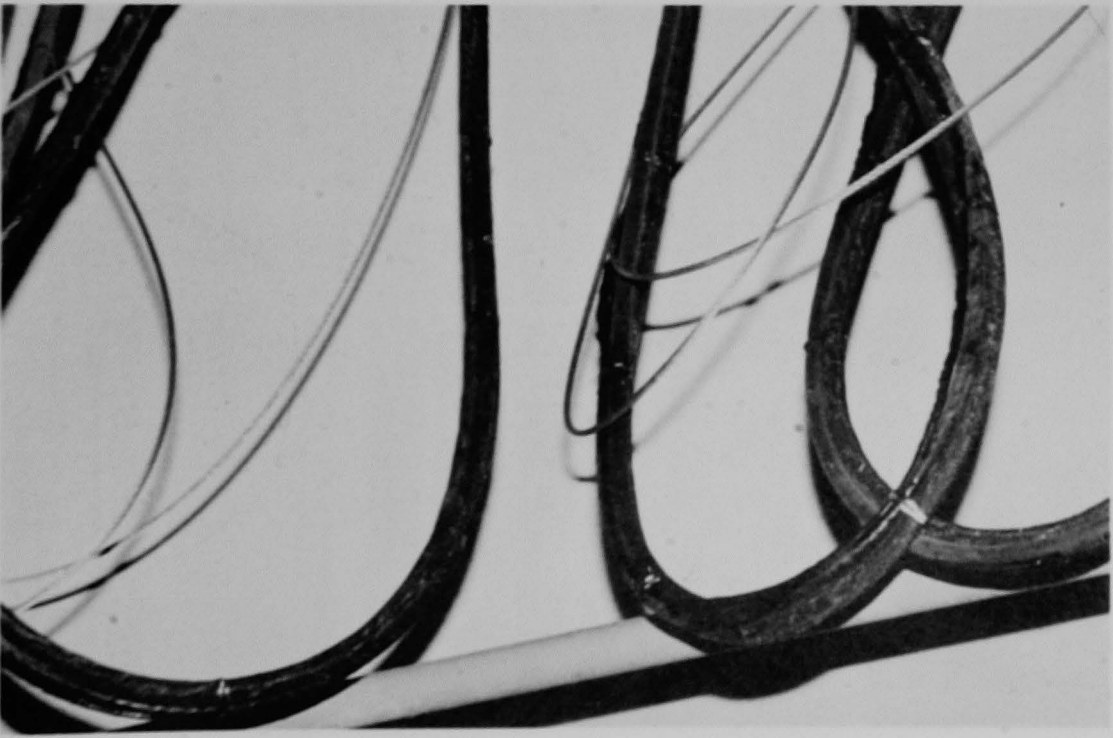

Figure 98 (5B) Close-up of hanging power cable to the auxiliary fuel handling bridge (see Figure 97, upper left).



Figure 99 (4A). Ventilation grill into the elevator shaft motor room (see Figure 97, upper left center).



Figure 100 (2A). Control rod drive mechanism cable trays (see Figure 97, left).



Figure 101 (2A). General view of operating deck, enclosed stairway, ventilation fixture, and indexing fixture (note crane buss bar fallen to deck).

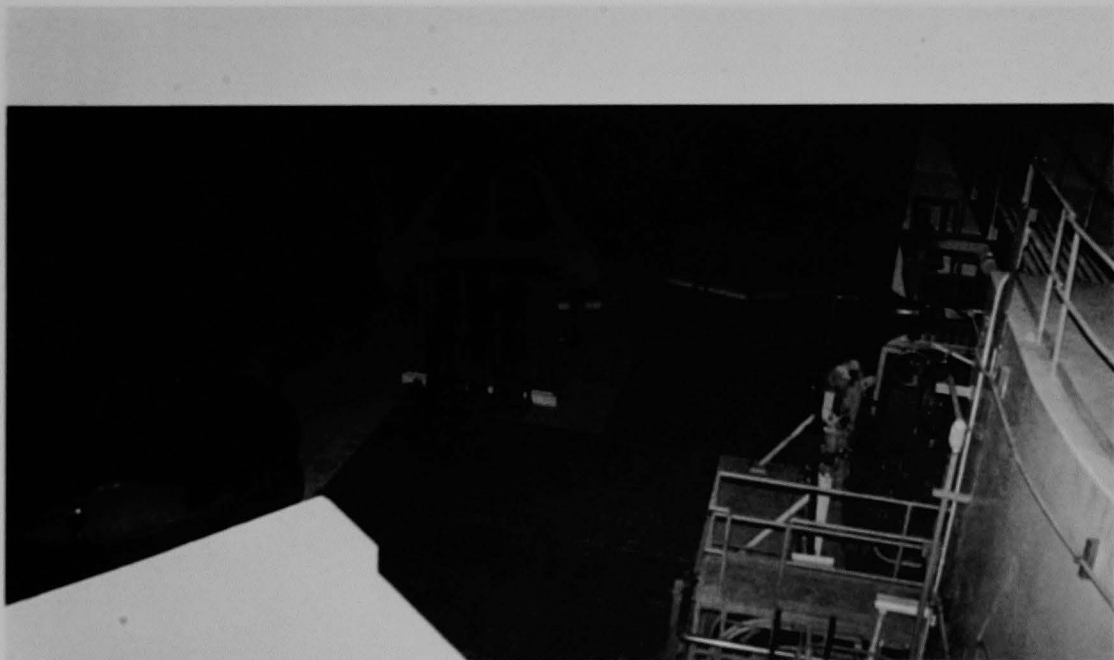

Figure 102 (5C). General view of operating deck from atop elevator shaft.



Figure 103 (5C). General view of operating deck from atop the elevator roof, second view.



Figure 104 (4B). Panorama: indexing fixture left, coolant pump alignment stand and cable chase right.



Figure 105 (5C). Operating deck from atop the elevator roof; technicians performing decontamination tests in background.



Figure 106 (5C). South end of elevator roof, HP R-211 dome monitor center; brackets for head lifting slings right.



Figure 107 (4A). Enclosed stairway; head lifting slings left, air duct right.

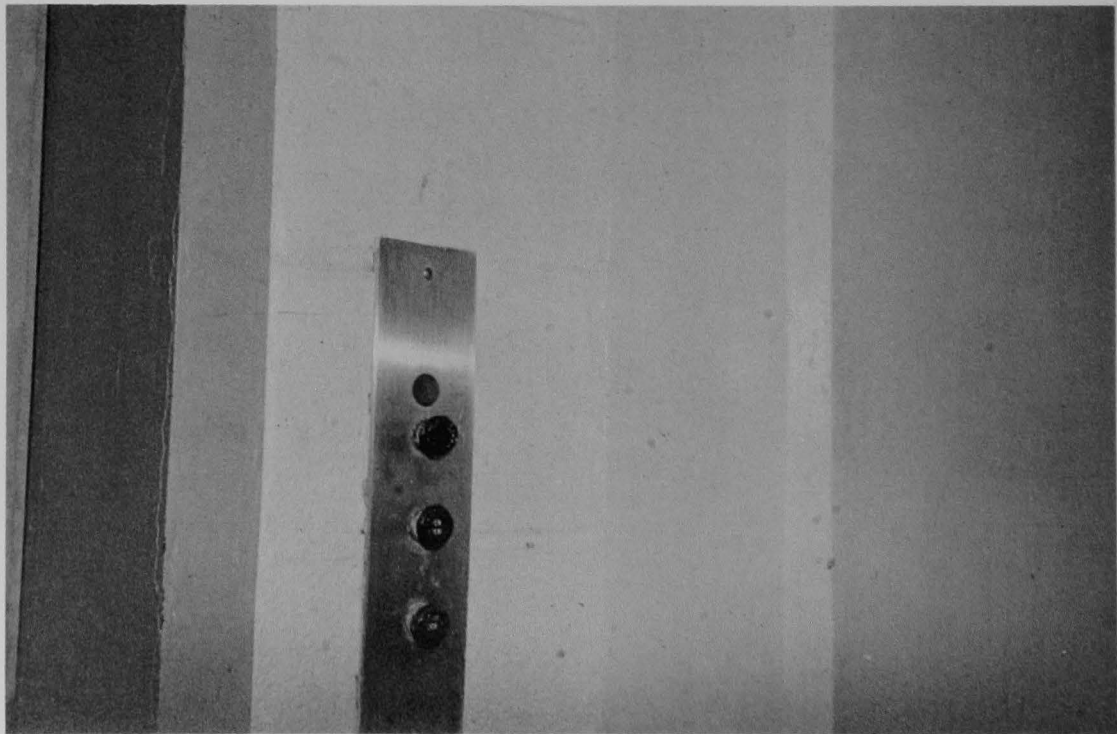

Figure 108 (6A). Close-up of elevator control buttons next elevator door (elevation 347).



Figure 109 (6A). Close-up of gap in elevator door (elevation 347).



Figure 110 (4A). Fifty-five gallon drum; northeast elevator wall right, containment liner background.



Figure 111 (4B). Fifty-five gallon drum, closer view of Figure 110.

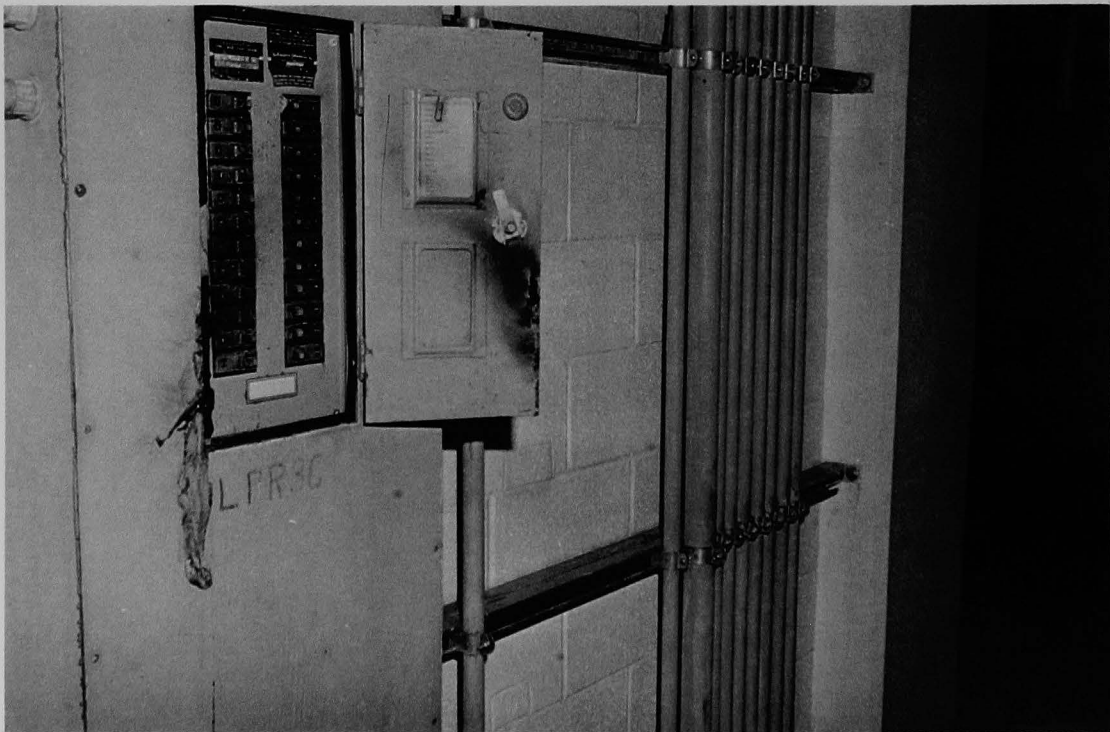

Figure 112 (6A). Northeast end of enclosed stairwell, electrical breaker box mounted on elevator wall.



Figure 113 (4A). Fifty-five gallon drum; northeast elevator wall in background.



Figure 114 (6A). General view of floor north of the enclosed stairwell; video camera on cart, fifty-five gallon drum, and elevator door in background.



Figure 115 (4A). Fifty-five gallon drum; corner of elevator wall left, D-ring wall background. Patches of paint lie on the floor.



Figure 116 (5C). South end of D-ring; head lifting pendants right.

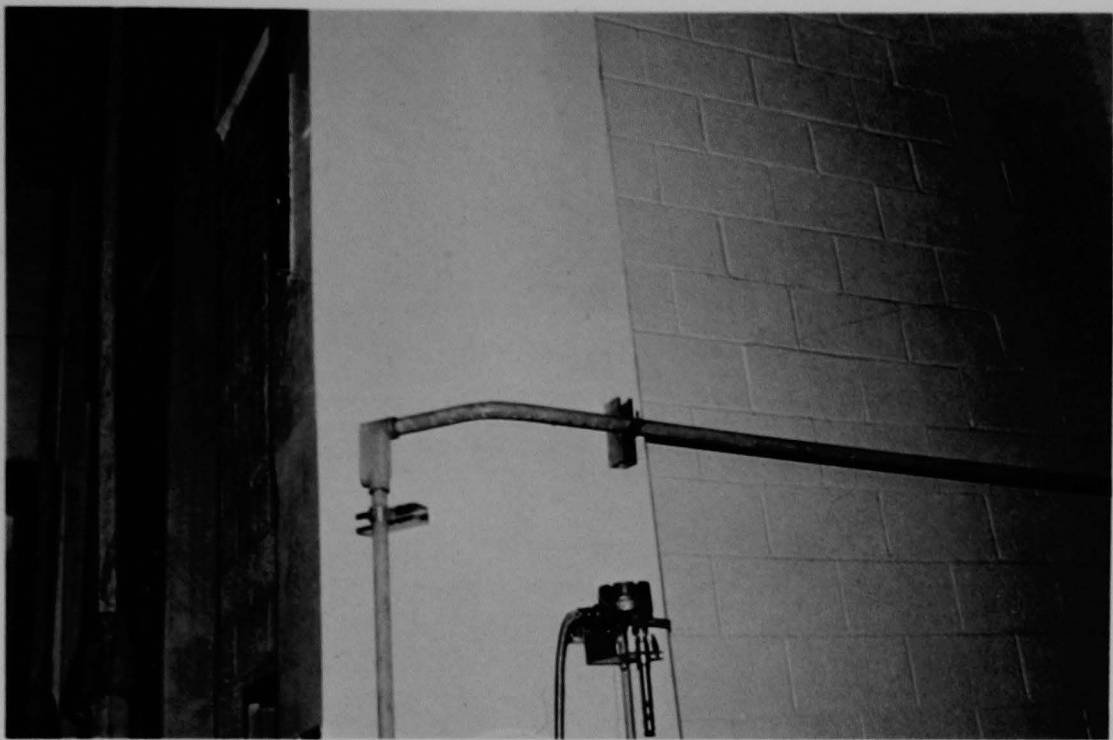

Figure 117 (2B). West corner of enclosed stairway; head lifting pendants left, temperature instrument center.



Figure 118 (5C). Operating deck from atop D-ring A, technicians performing decontamination tests.



Figure 119 (2B). Area between south wall of enclosed stairway and air duct.



Figure 120 (4). Crane power cable and insulation lying over tool box south of enclosed stairwell (see Figure 119).



Figure 121 (4A). Tool box and drums between enclosed stairwell and air duct.



Figure 122 (4A). Fifty-five gallon drums between enclosed stairwell and air duct.



Figure 123 (6A). Lifting sling lying on floor south of enclosed stairwell (see Figure 118).



Figure 124 (4A). Fifty-five gallon drums; air duct and enclosed stairwell left, containment liner right.

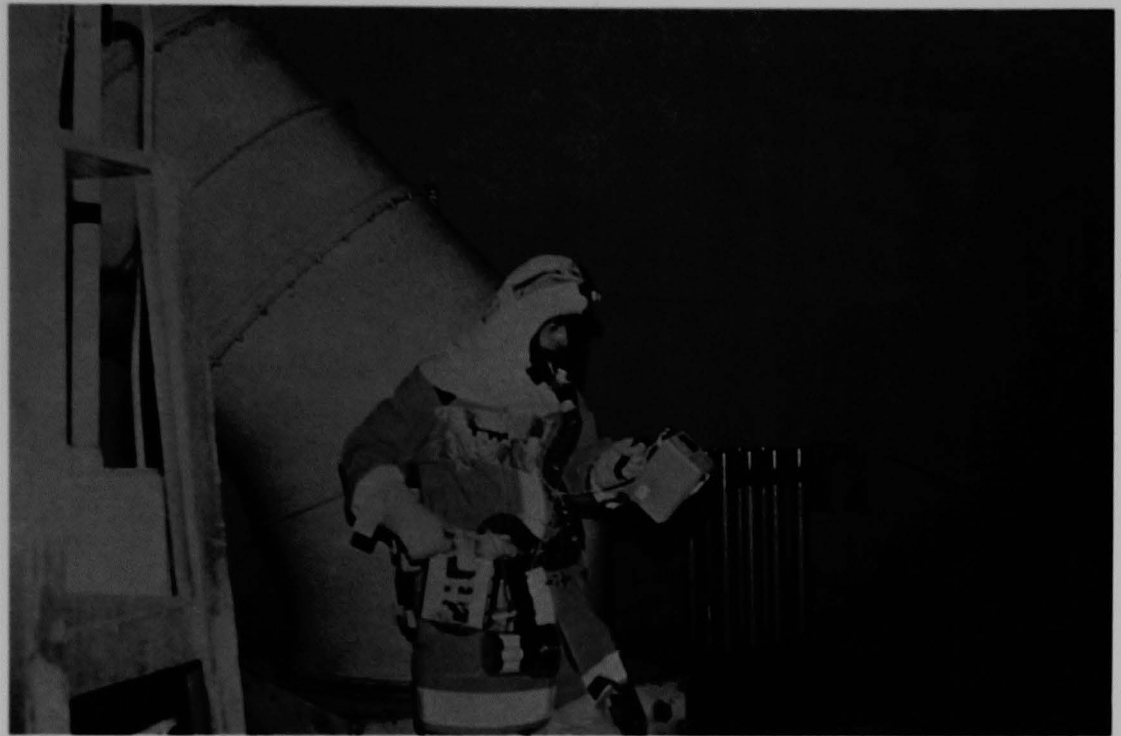

Figure 125 (2B). Radiation surveying southwest of enclosed stairway (cf. Figure 118 background left).

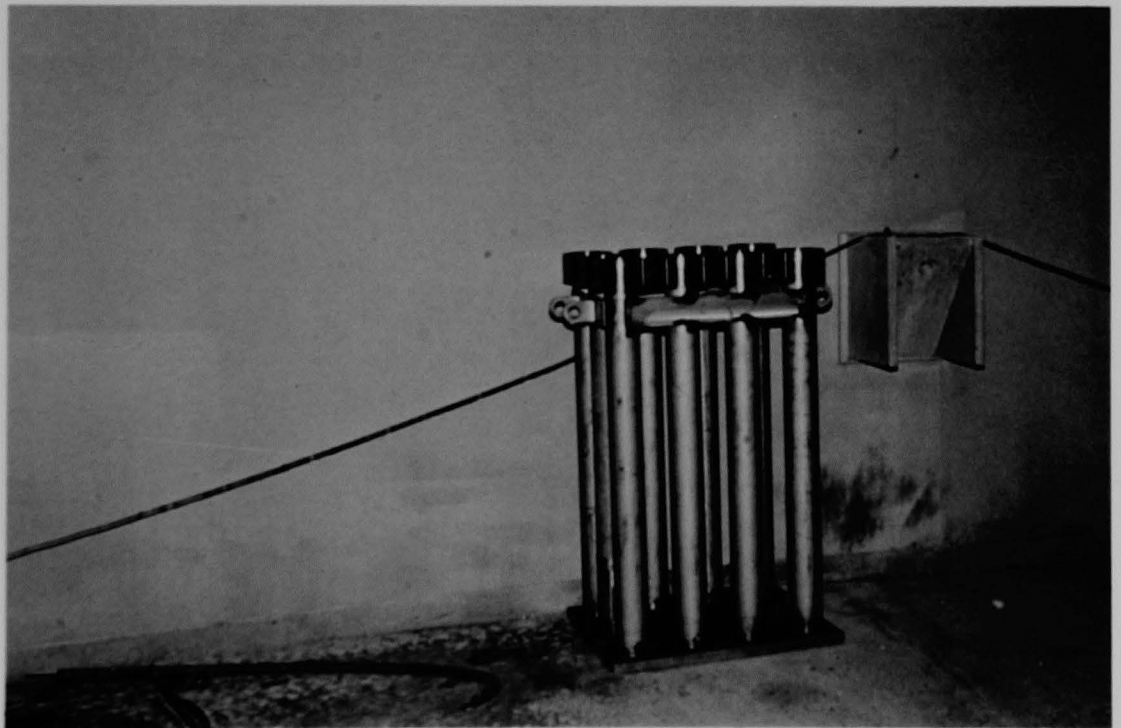

Figure 126 (2B). Stainless steel specimen capsule storage stand.



Figure 127 (4A). Wood blocks; liner left, technician right (cf. Figure 125, right).



Figure 128 (5C). Auxiliary fuel handling bridge area.

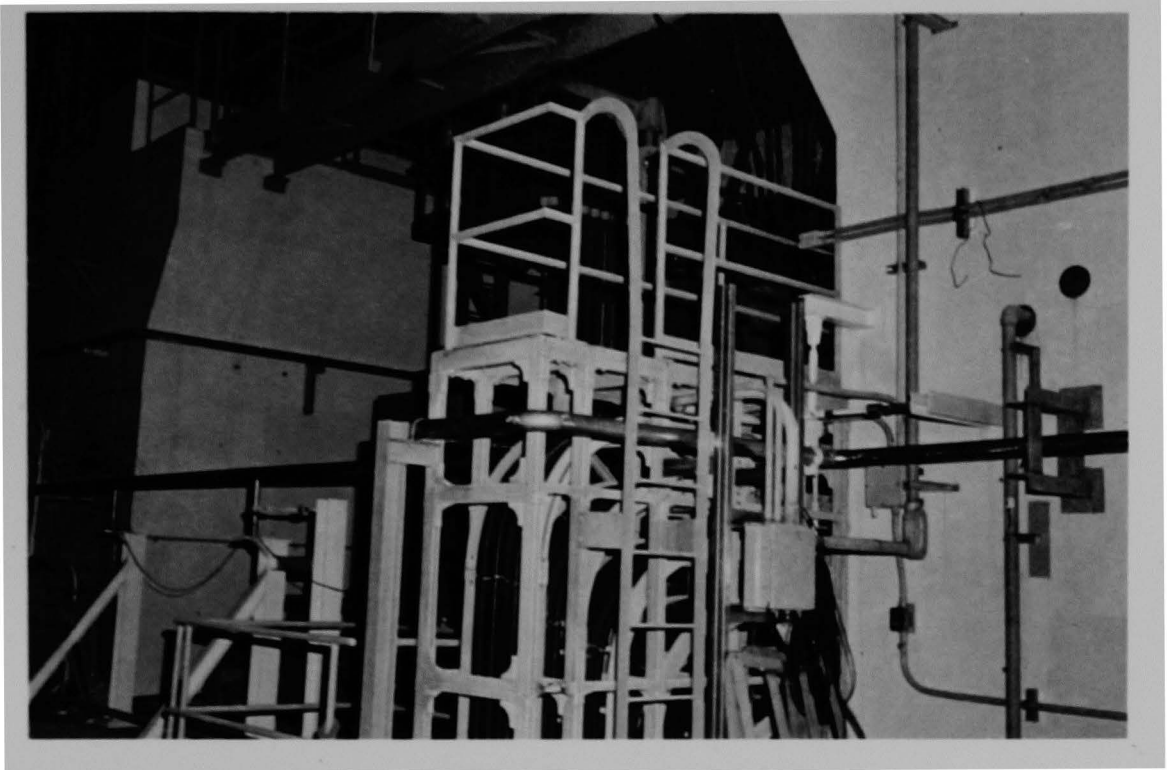

Figure 129 (2A). Control rod drive mechanism cable trays (see Figure 97, left).

ELEVATION 347

QUADRANT 2



Figure 130 (4B). Scaffolding around top of head lifting rig (plastic covered); internals indexing fixture left, telephone bench background.

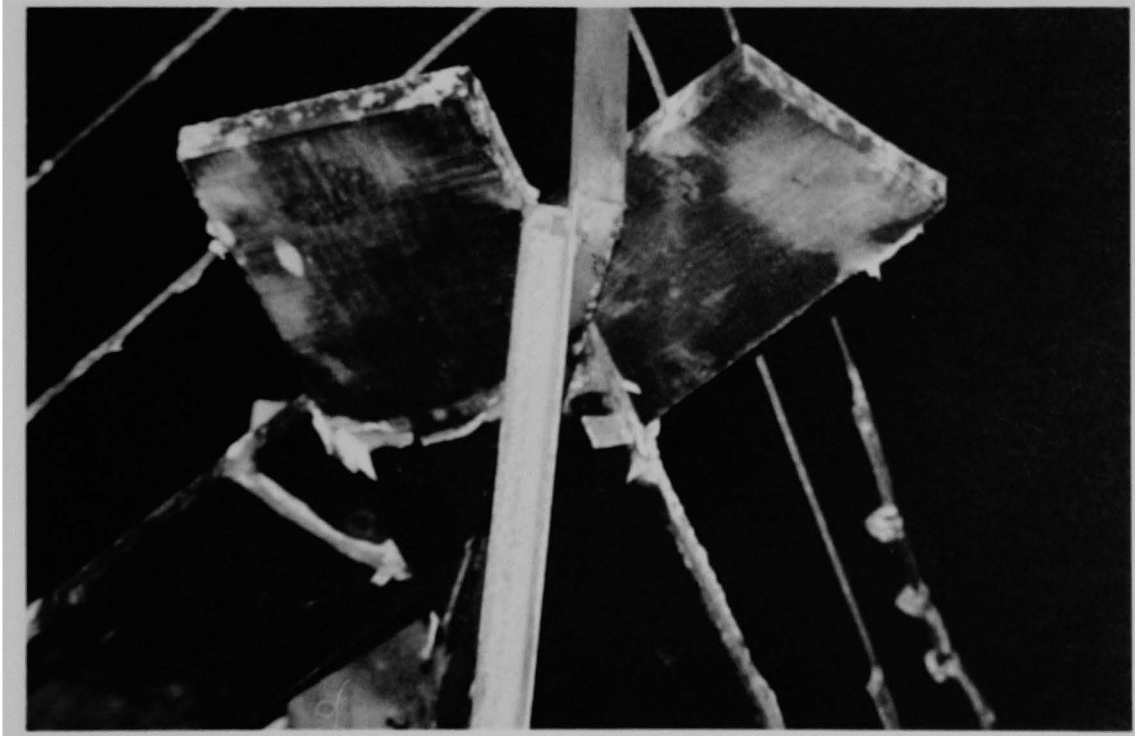

Figure 131 (4B). Scaffolding (see Figure 130).

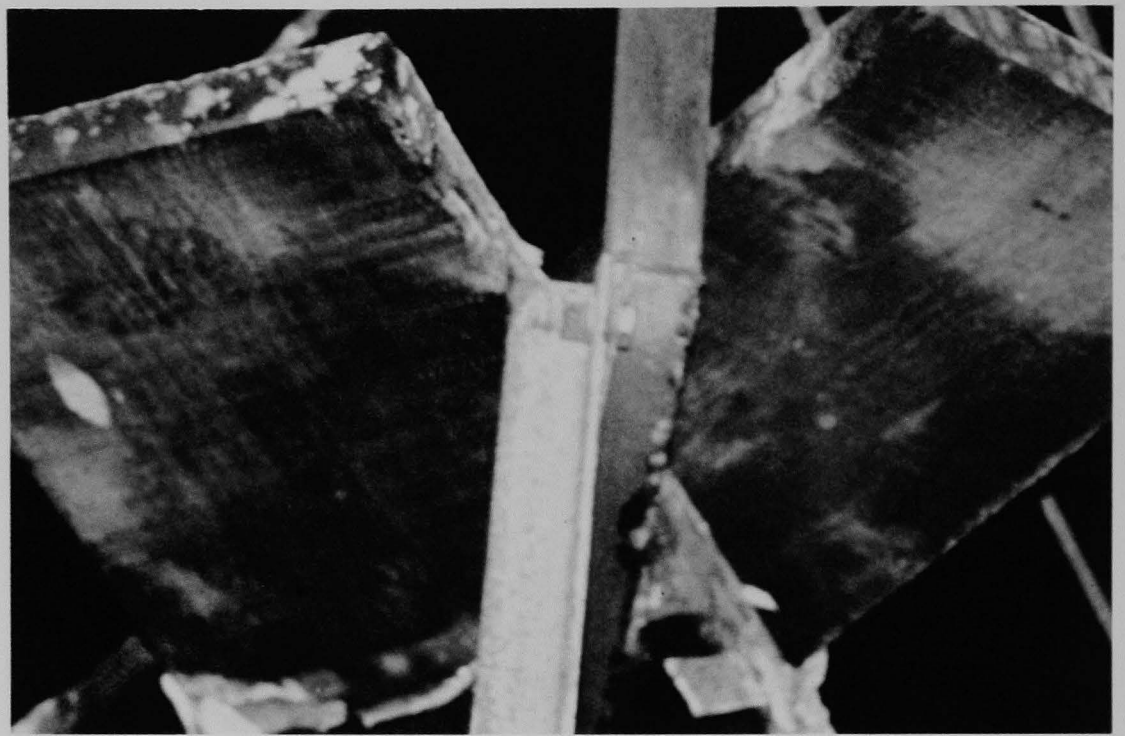

Figure 132 (4B). Close-ups of boards on scaffolding (see Figure 130).

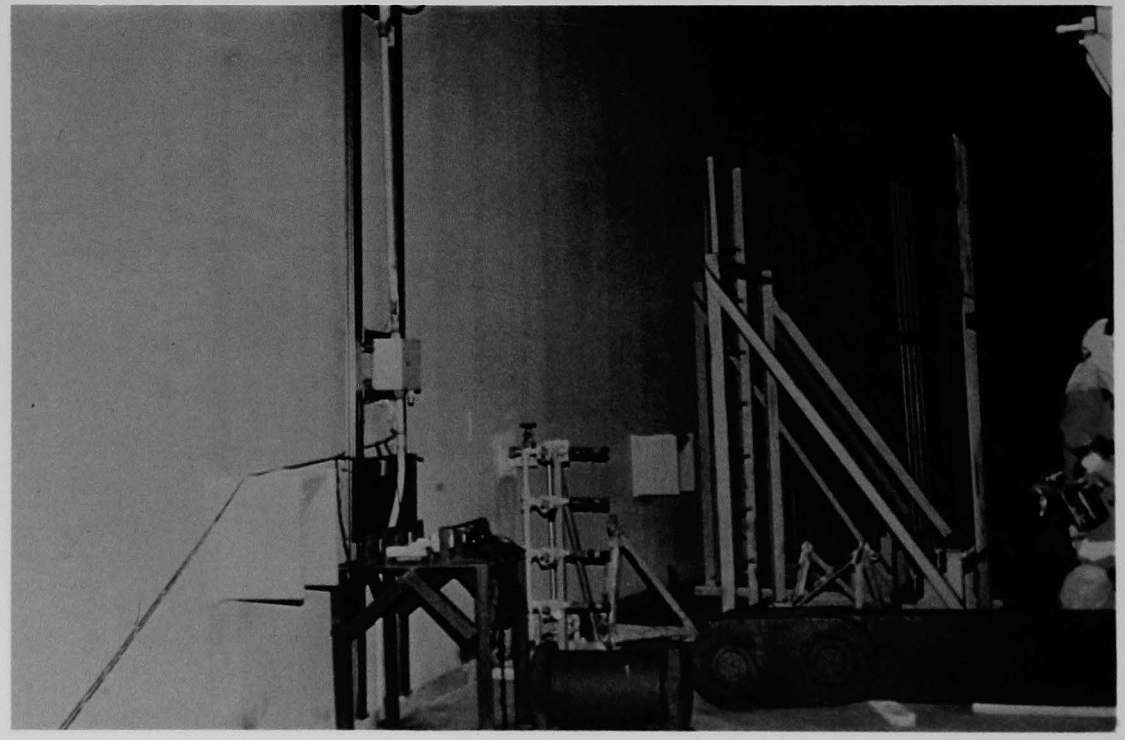

Figure 133 (2B). South liner wall: telephone bench, internals handling extension on floor, storage stand behind, internals indexing fixture right.

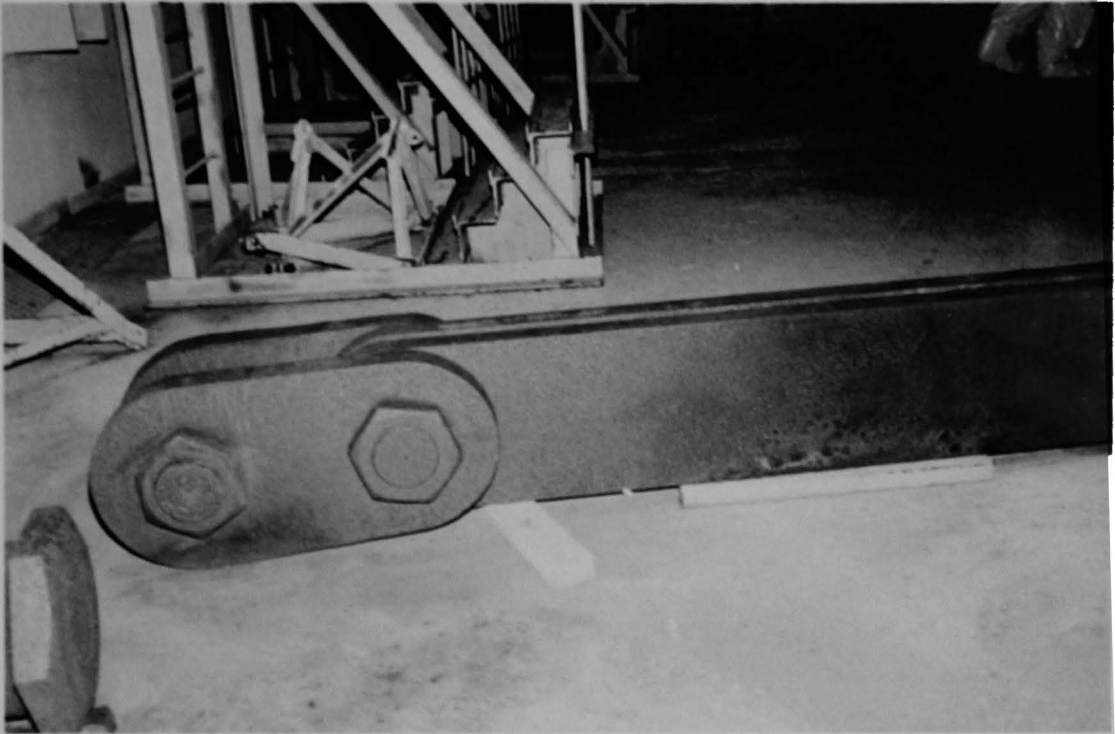

Figure 134 (2B). Close-up of internals handling extension.

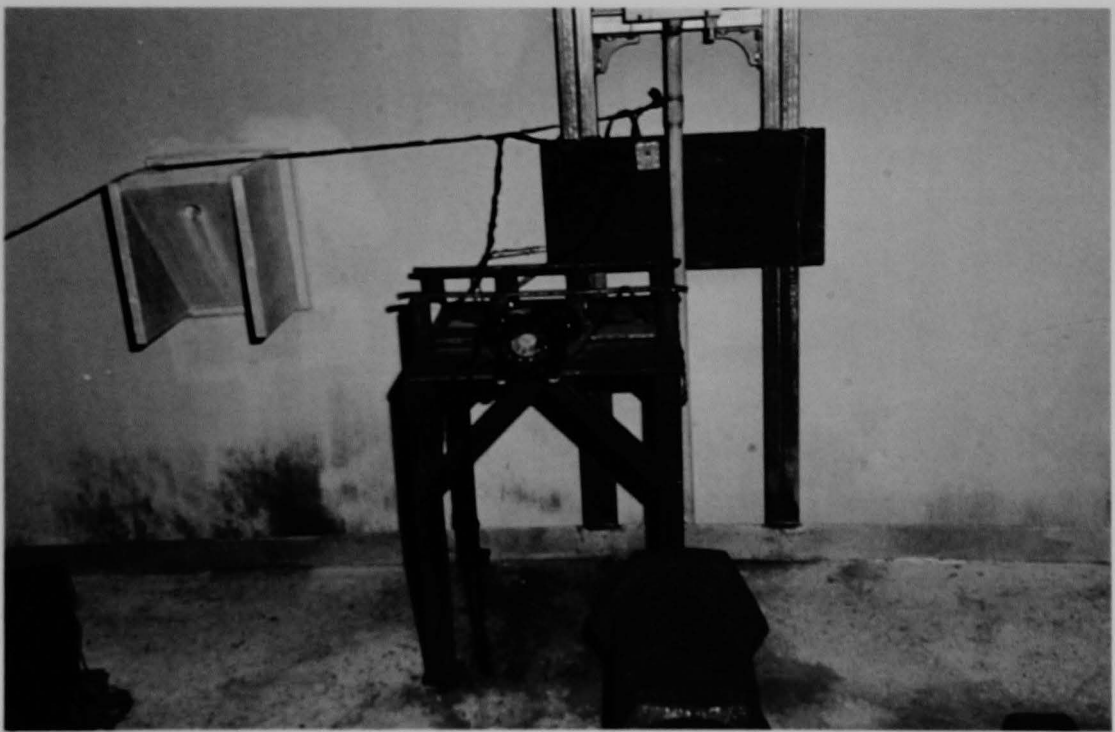

Figure 135 (4A). Telephone bench, due south against liner.

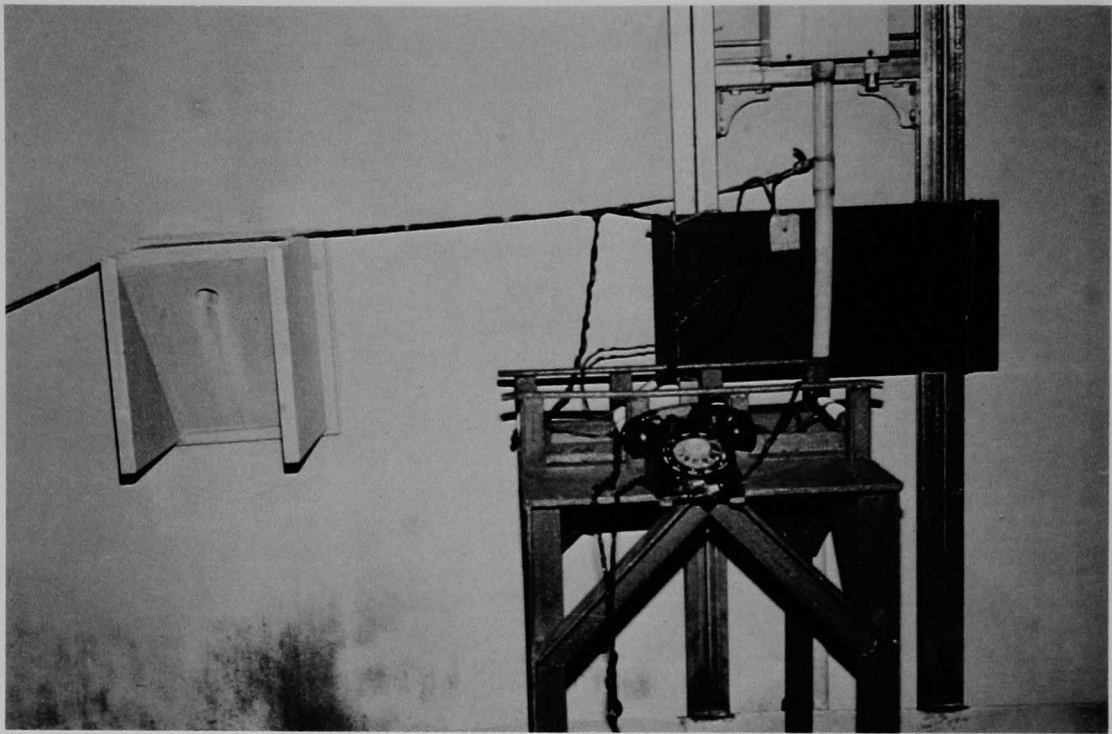

Figure 136 (2B). Bell Telephone.



Figure 137 (5C). Closer view of Bell Telephone.



Figure 138 (5B). Close-up of Bell Telephone.



Figure 139 (4). Close-up of Bell Telephone, second view .

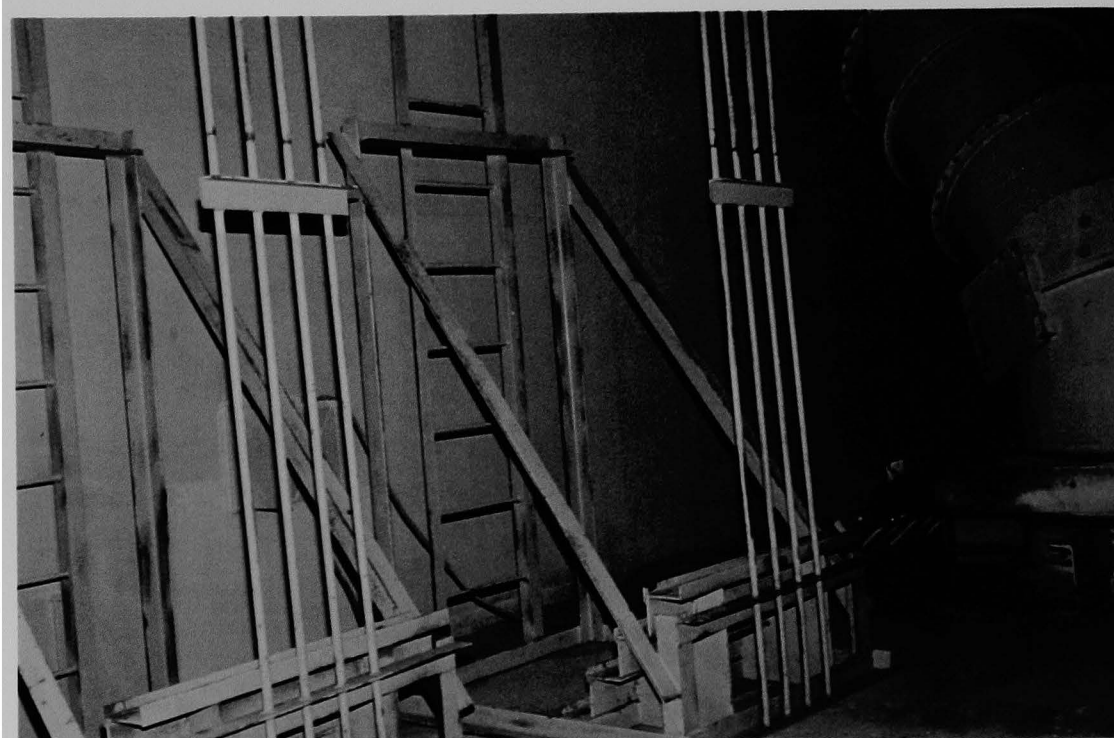

Figure 140 (2B). Storage stands for the mirror insulation.



Figure 141 (5C). Decontamination test area in front of mirror insulation storage stands.



Figure 142 (5C). Close-up of decontamination test (see Figure 141).

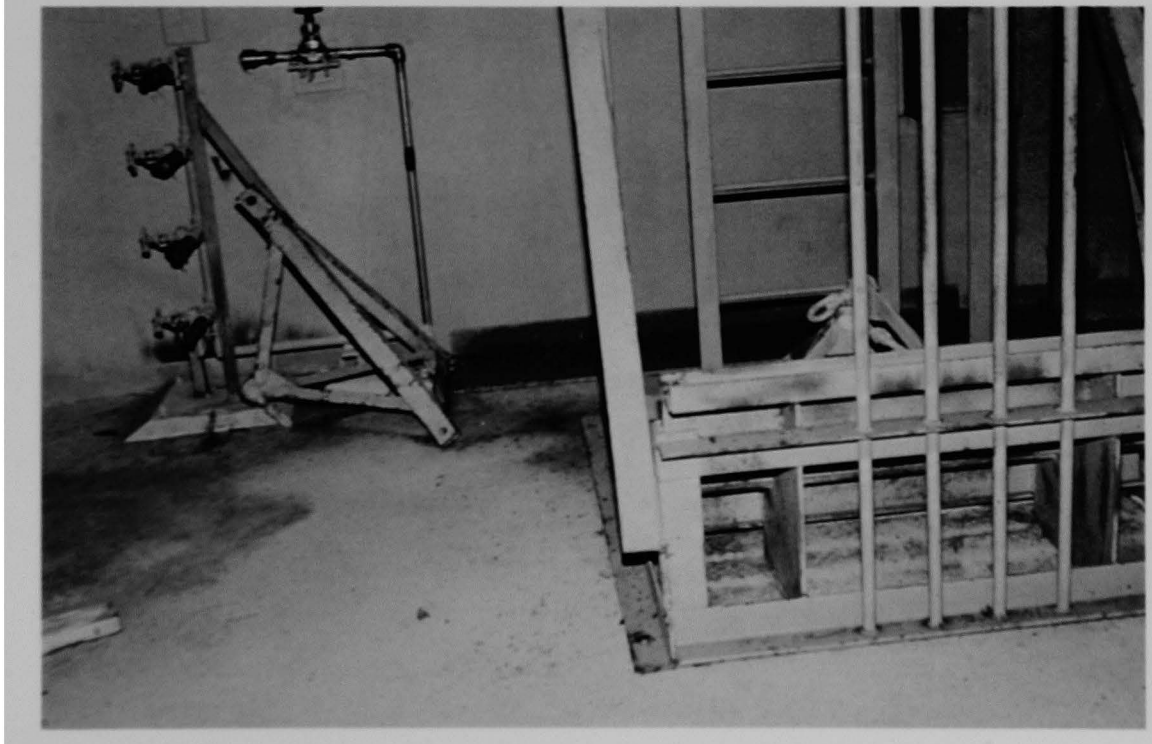

Figure 143 (2B). Close-up of the storage stand for the mirror insulation (standard carbon steel pinated).



Figure 144 (2B). Panorama west from the enclosed stairwell; indexing fixture left, internals handling pendants in their storage stands and reactor coolant pump with vessel head and internals center.



Figure 145 (5C). Reactor coolant pump alignment stand and internals handling pendants.



Figure 146 (2B). Base of reactor coolant pump alignment stand.



Figure 147 (2B). HP technicians preparing to take an area swipe; air duct left, reactor coolant pump stand right.



Figure 148 (2B). Close-up of the seal plate, in two pieces (as a circle, it is used in the transfer canal to seal the annulus between the canal and reactor vessel during refueling).

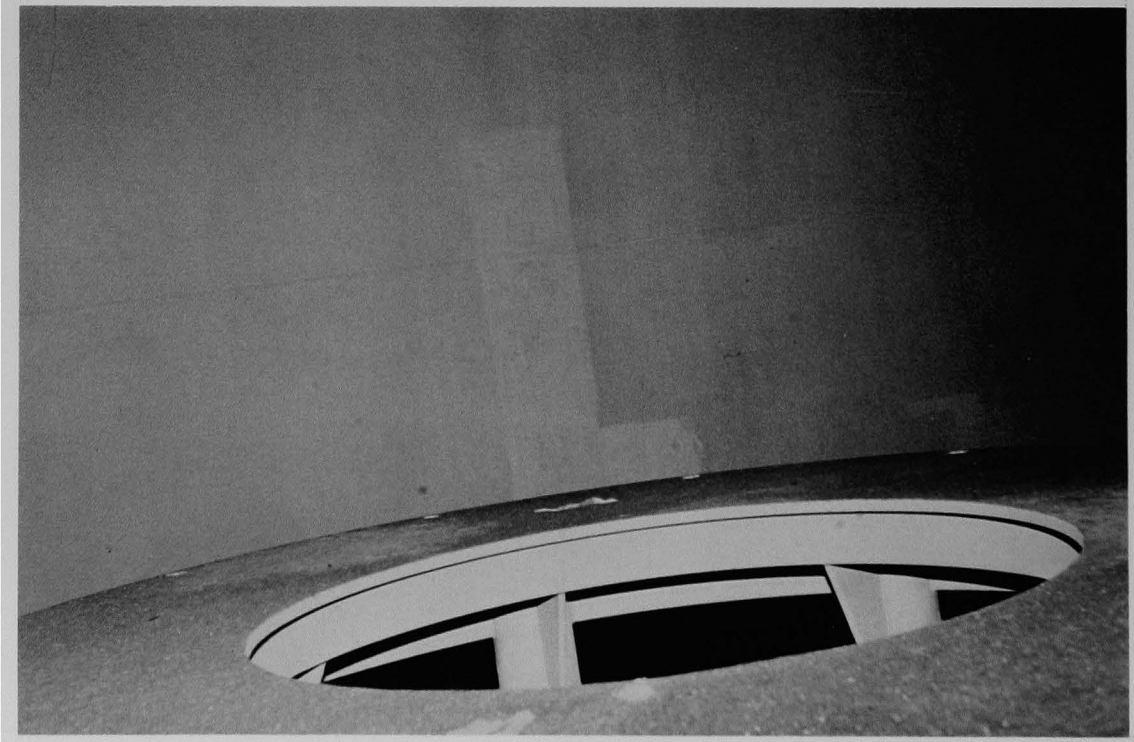

Figure 149 (2B). Top of reactor coolant pump motor stand.

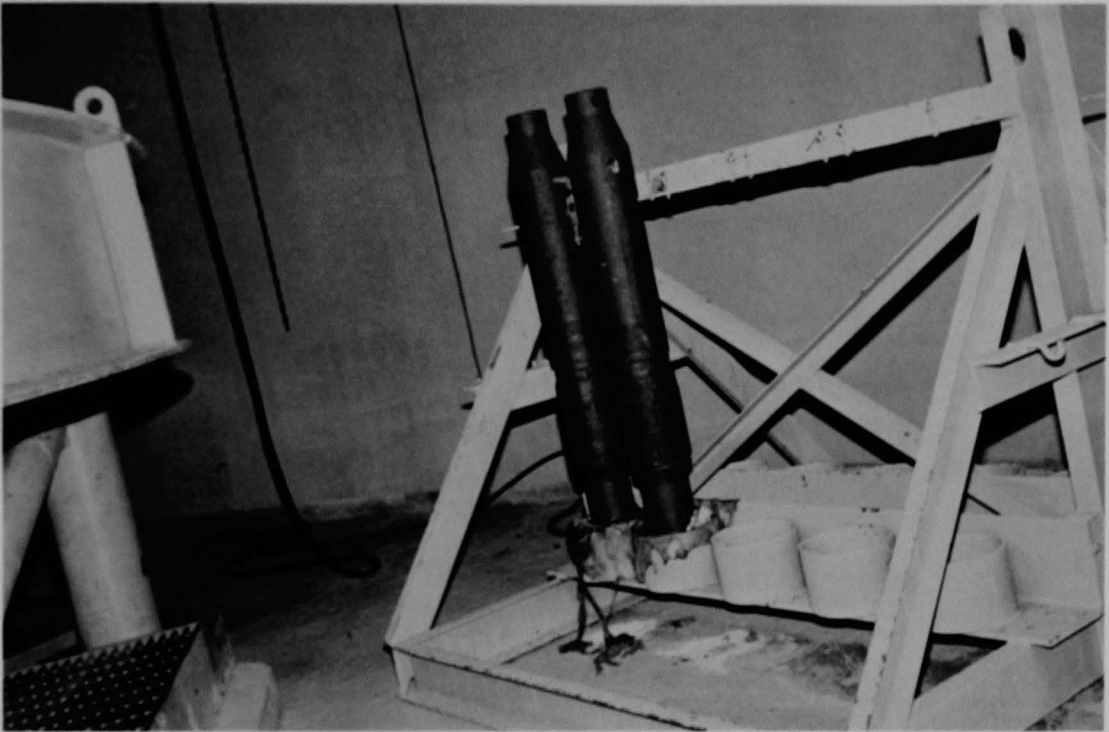

Figure 150 (2B). Storage stand for the reactor vessel studs.

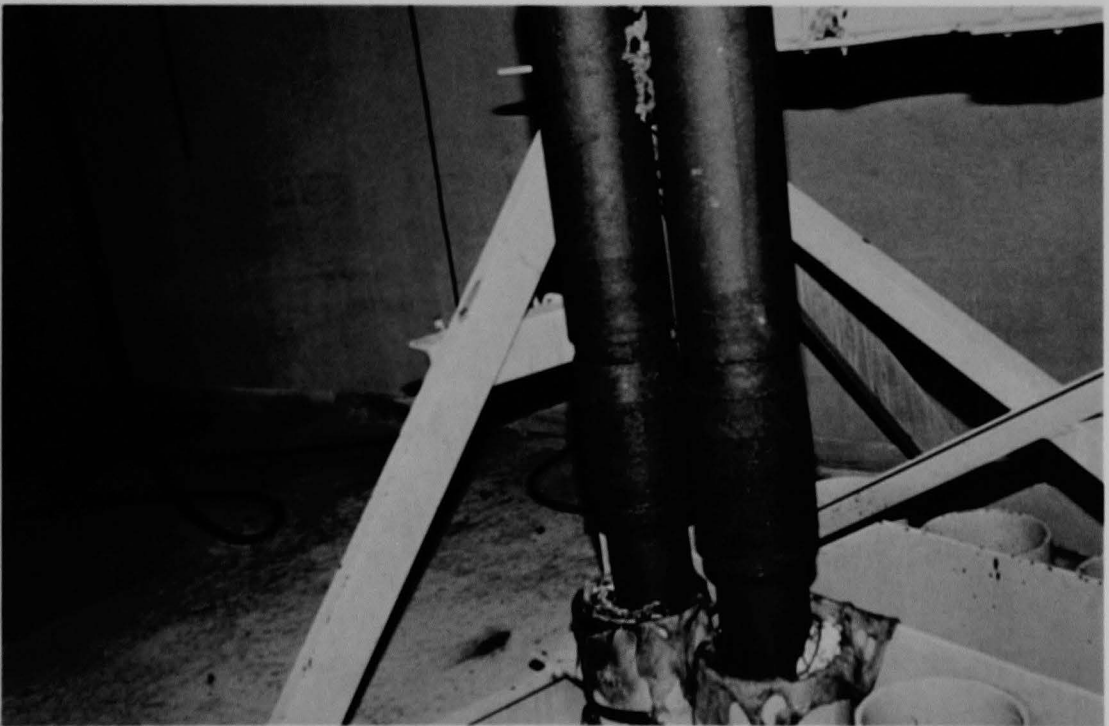

Figure 151 (2B). Reactor vessel guide studs.

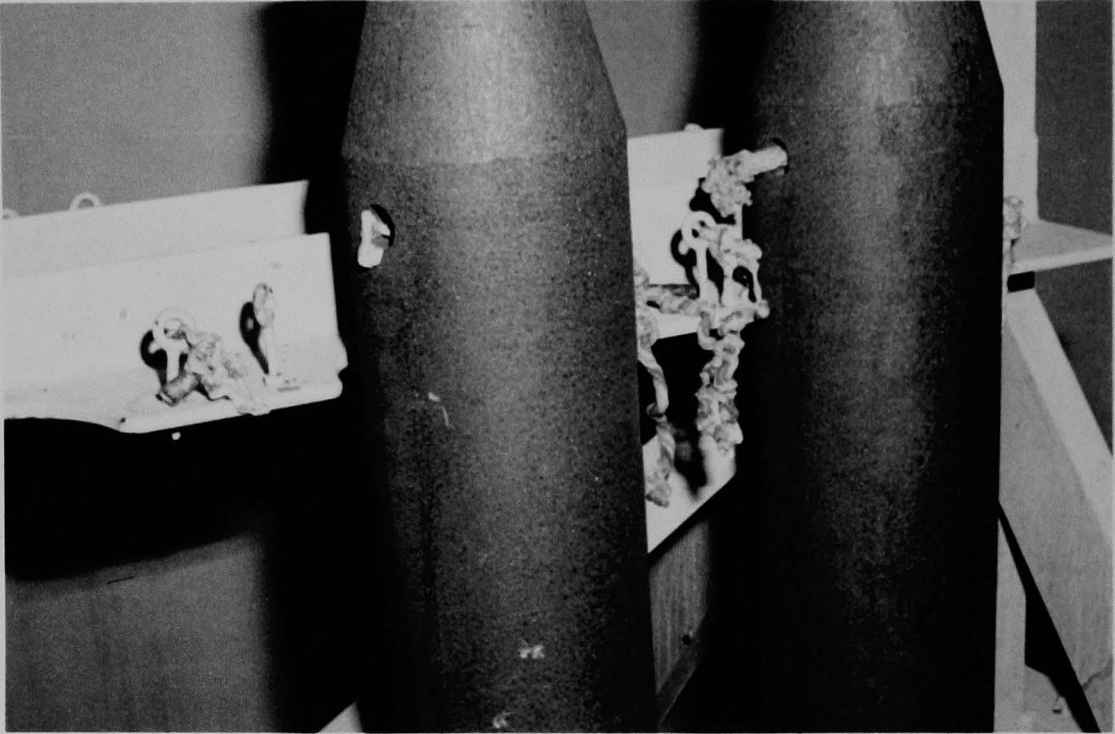

Figure 152 (4). Close-up of reactor vessel guide studs and melted rod rope.

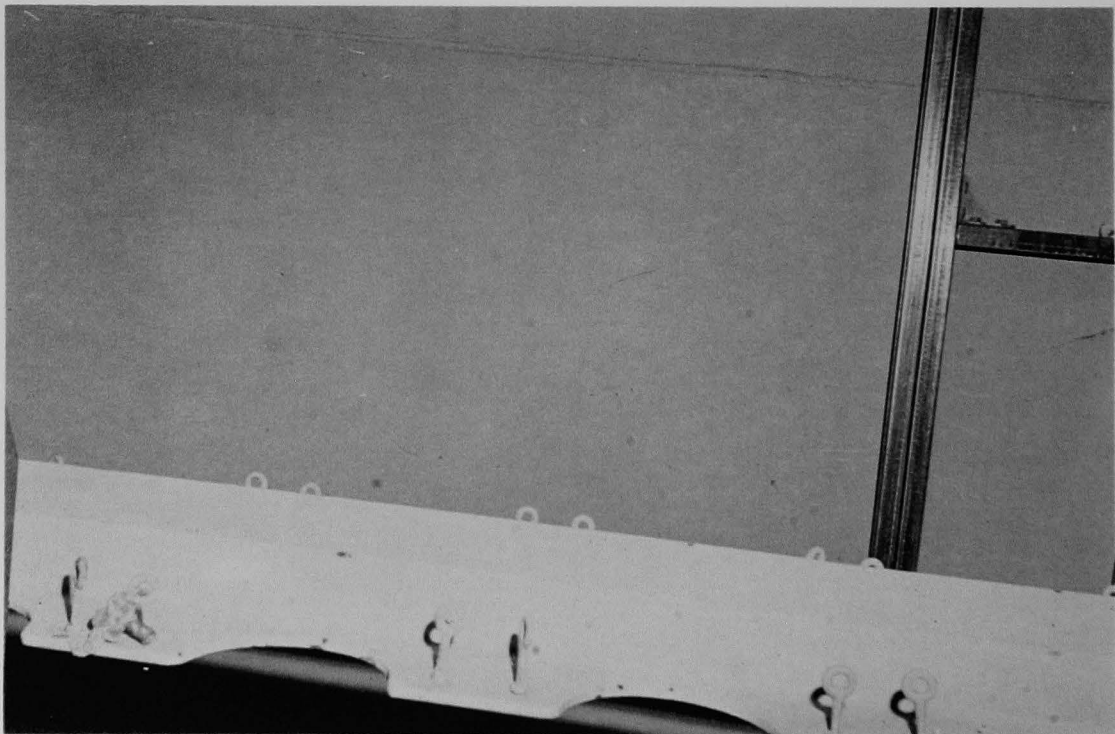

Figure 153 (6A). A top portion of the reactor vessel stud storage stand.



Figure 154 (2B). Internals lifting pendant.



Figure 155 (5C). Reactor coolant pump alignment stand; coolant pump motor stand right.



Figure 156 (5B). Reactor vessel head storage stand.

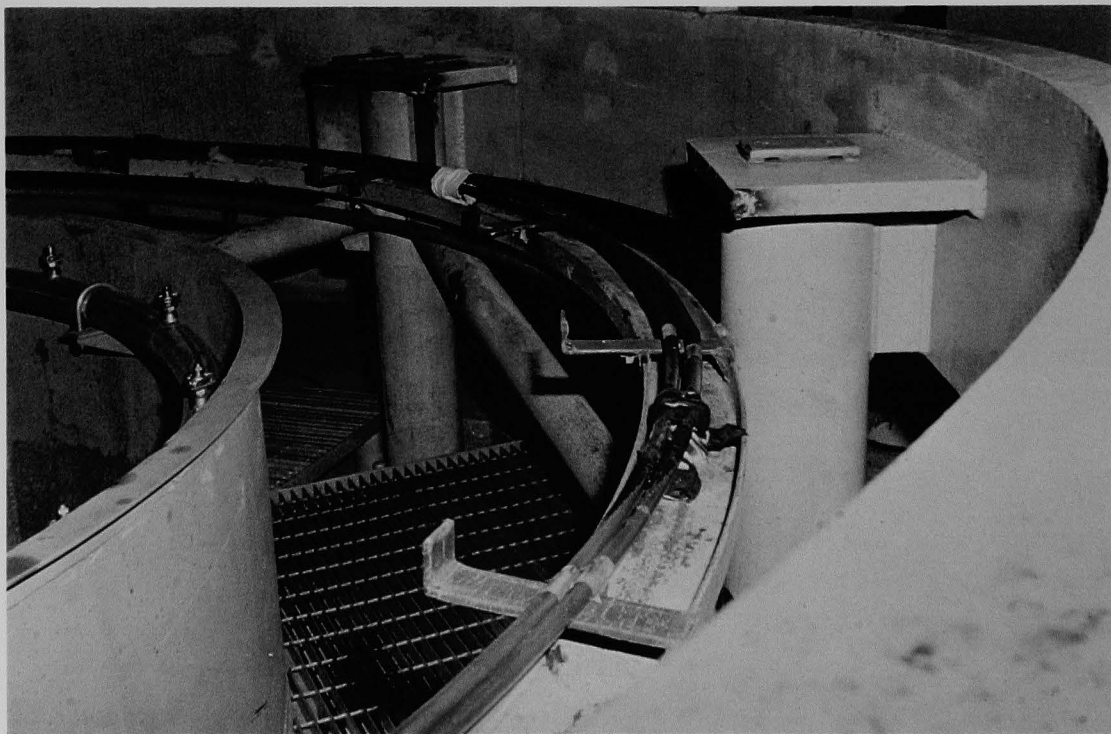

Figure 157 (6A). View inside of the head storage stand, looking west (tops of vessel guide studs appearing above rim); stainless steel spray line left.

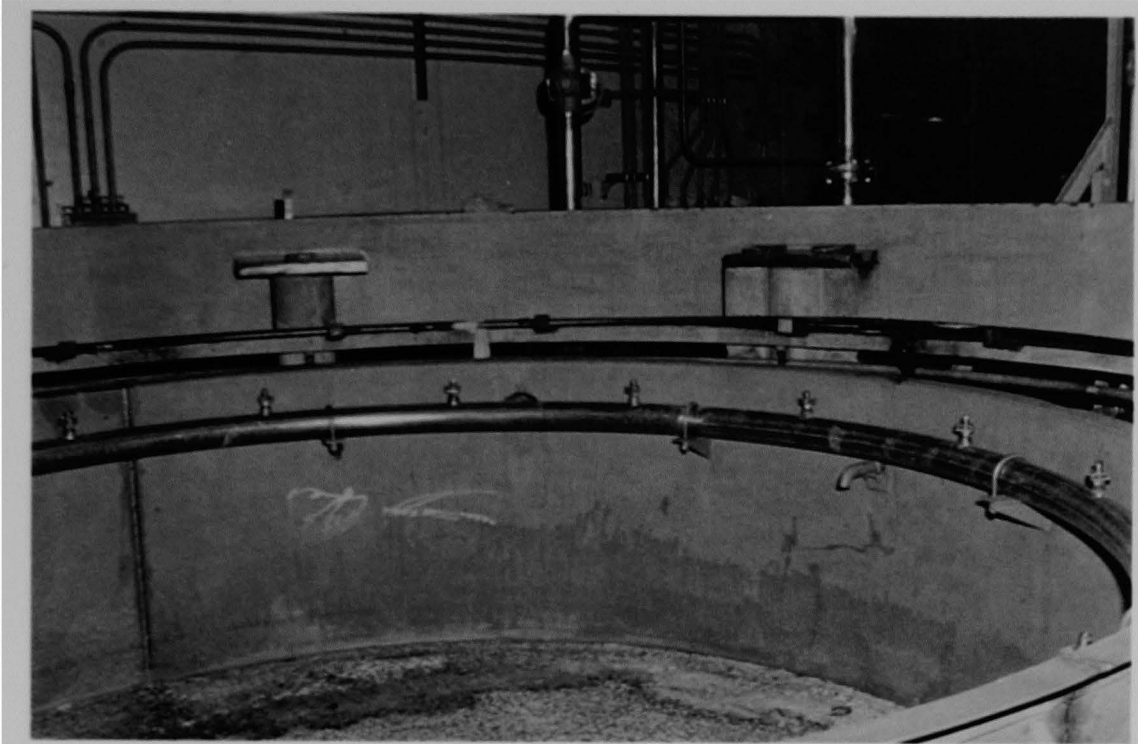

Figure 158 (6A). Northeast view inside of the head storage stand at stainless steel spray line used to decontaminate the reactor head.

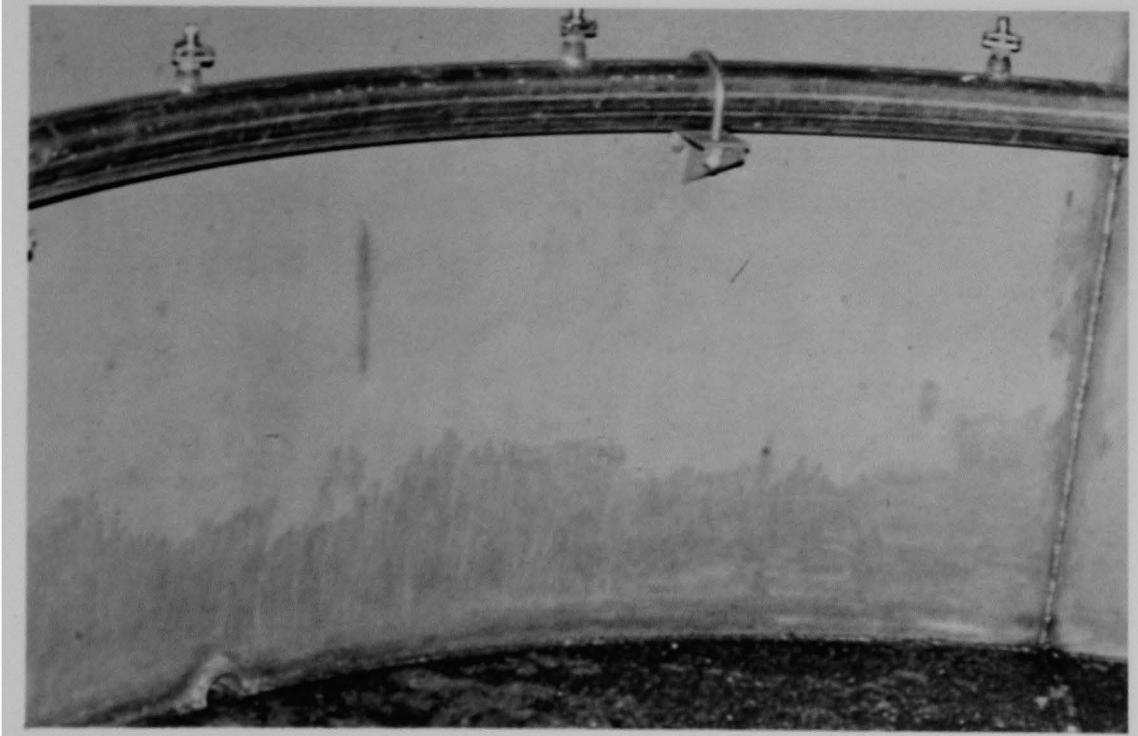

Figure 159 (4B). Section of the stainless steel spray line inside of the head storage stand.



Figure 160 (2B). Close-up of the reactor vessel head storage stand; open stairway in background.

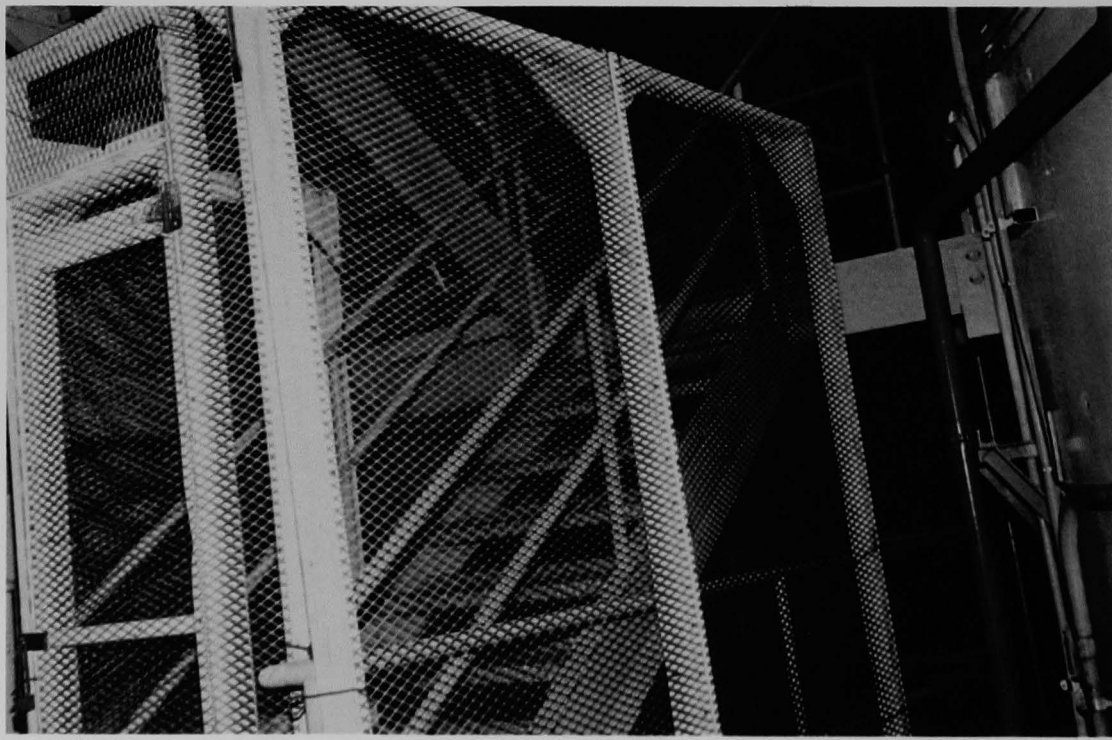

Figure 161 (2B). Open stairway, caged to prevent entry without permission to top of D-ring A.

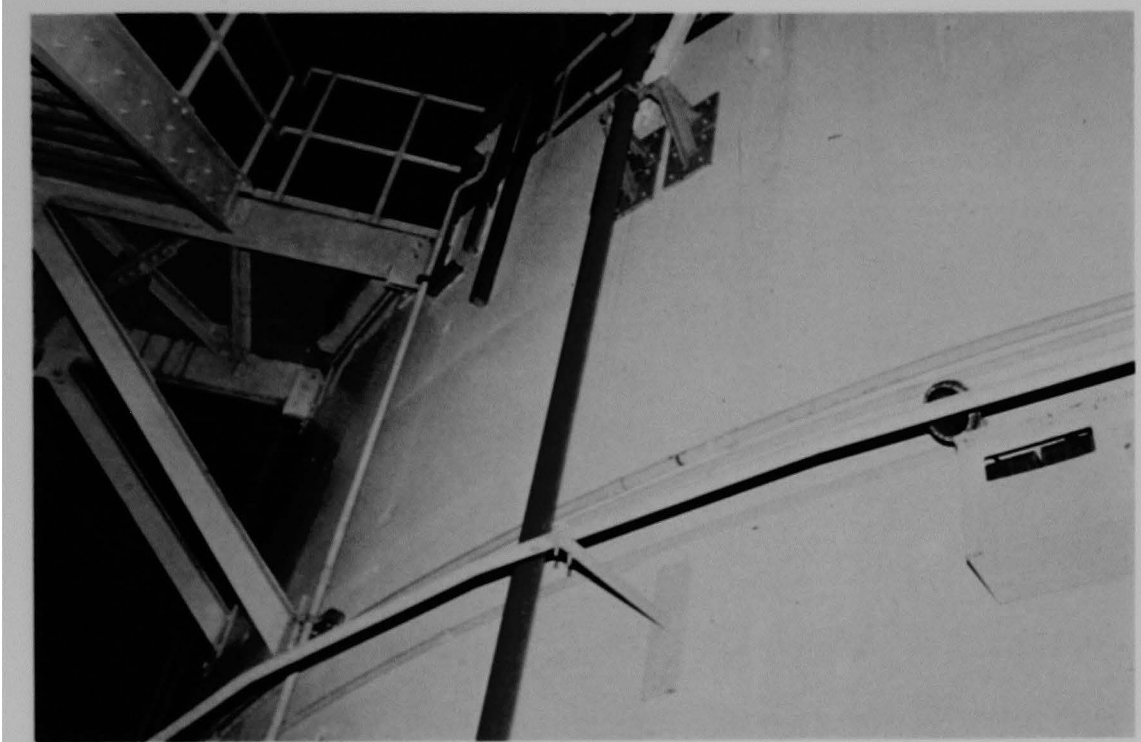

Figure 162 (2B). Crosswalk leading from top of open stairway to the east D-ring.

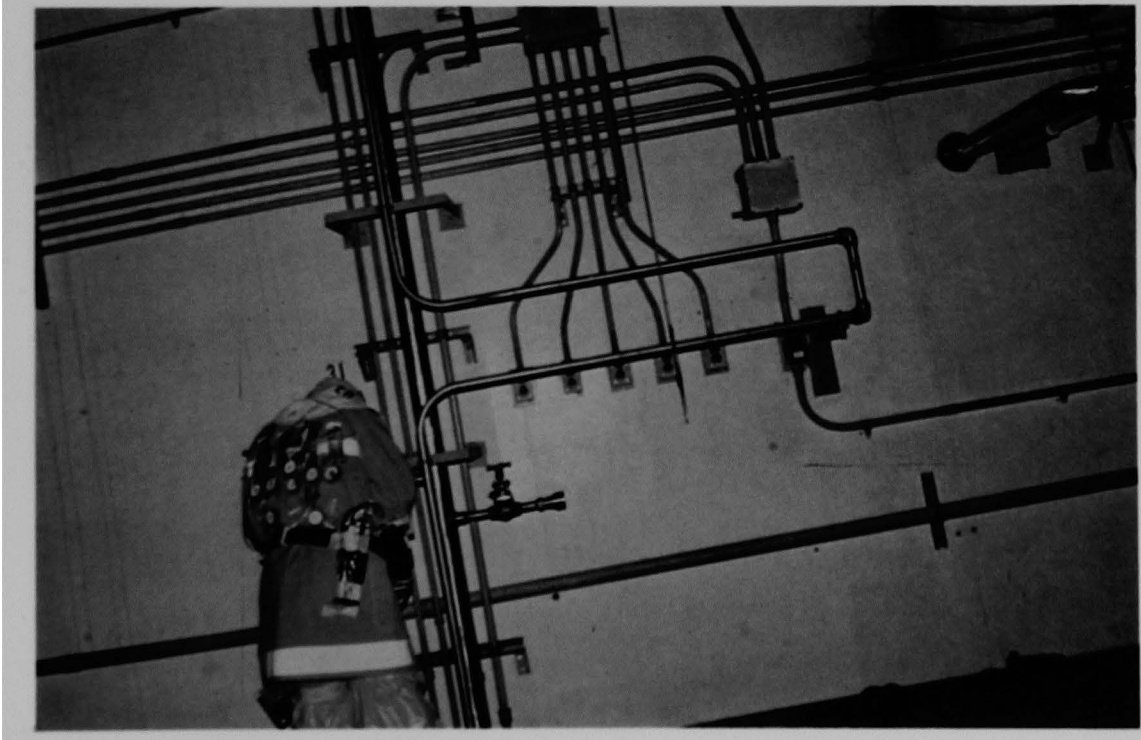

Figure 163 (2B). Southwest side of D-ring (extension left of Figure 167).



Figure 164 (2A). Corner of west D-ring, view opening on auxiliary fuel handling bridge.



Figure 165 (2B). Auxiliary fuel handling bridge from southwest.



Figure 166 (5C). Panorama across the operating deck; pump stand right, enclosed stairwell background.



Figure 167 (4). Southeast across the operating deck toward the enclosed stairwell; technicians are working with video camera.



Figure 168 (4A). Floor grating over core flood tank B; D-ring wall and auxiliary fuel handling bridge background.

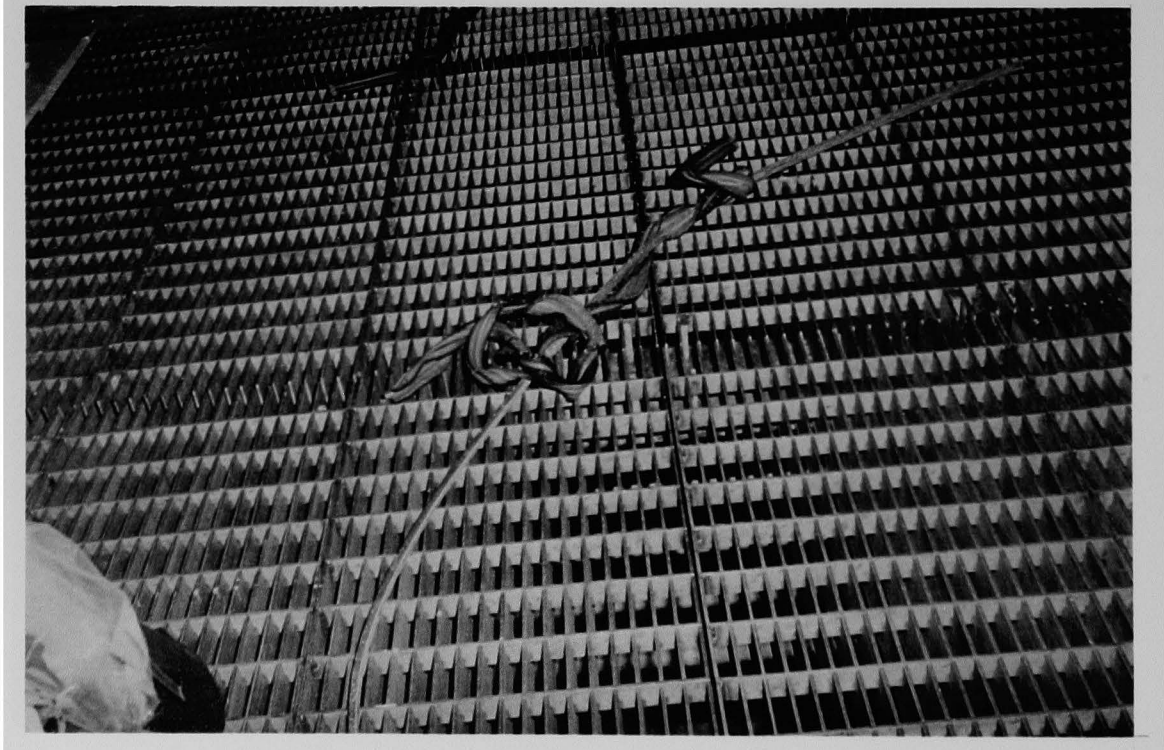

Figure 169 (4A). Polar crane power cable and insulation on grating over core flood tank B.



Figure 170 (2B). Extension pendant handing from the handling fixture atop the pump stand.

ELEVATION 347

QUADRANT 3



Figure 171 (2B). Area just north of the open stairway.



Figure 172 (2B). Incore instrumentation electrical connections (first view); steel structure on fuel handling bridge background right.

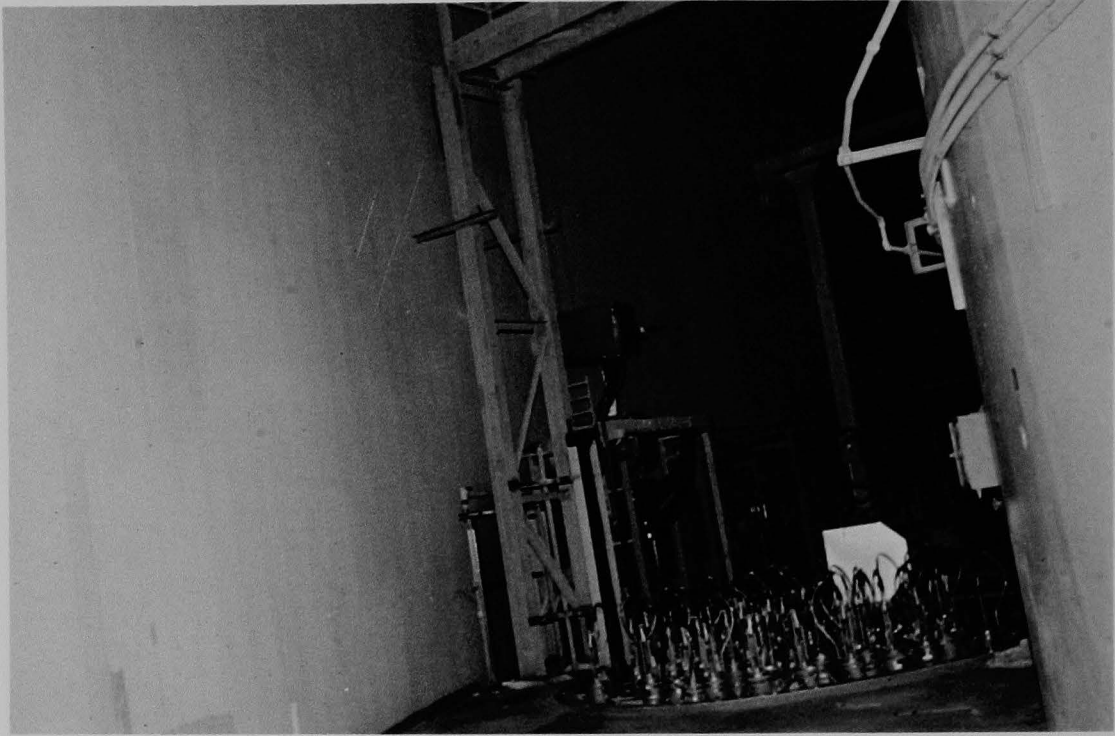

Figure 173 (2B). Incore instrumentation electrical connections (second view); steel structure on fuel handling bridge background right.

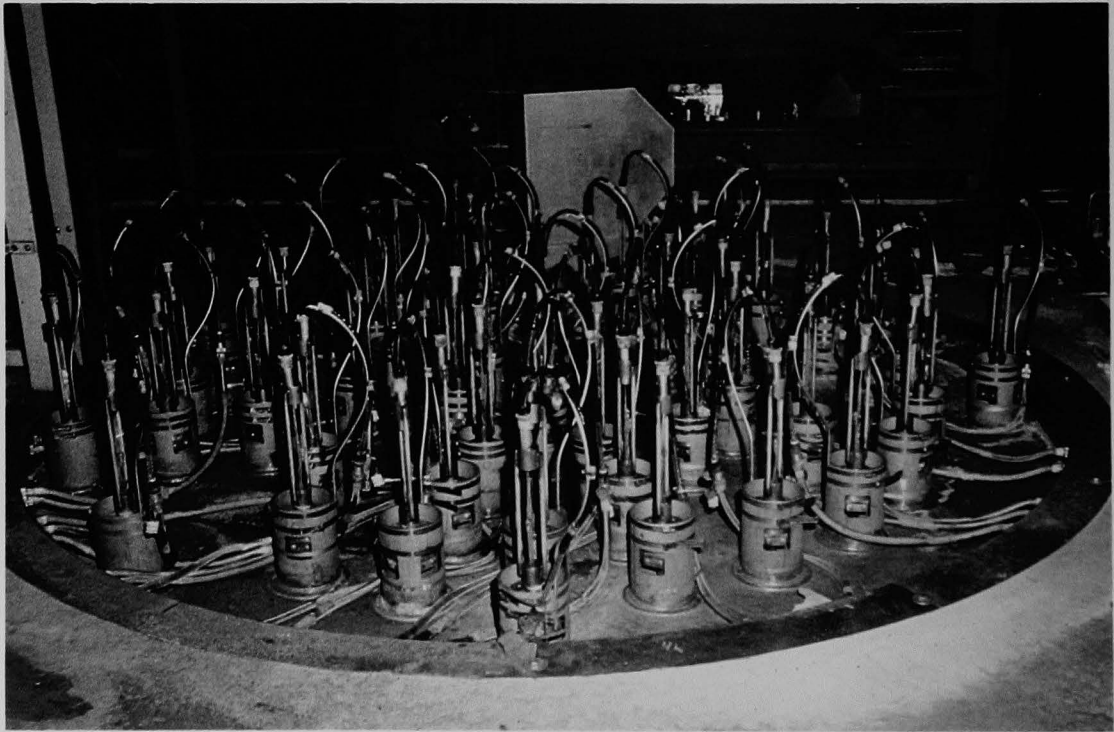

Figure 174 (4A). Incore instrumentation electrical connections; main fuel handling bridge background. (This photograph was taken to document boron crystal accumulation.)

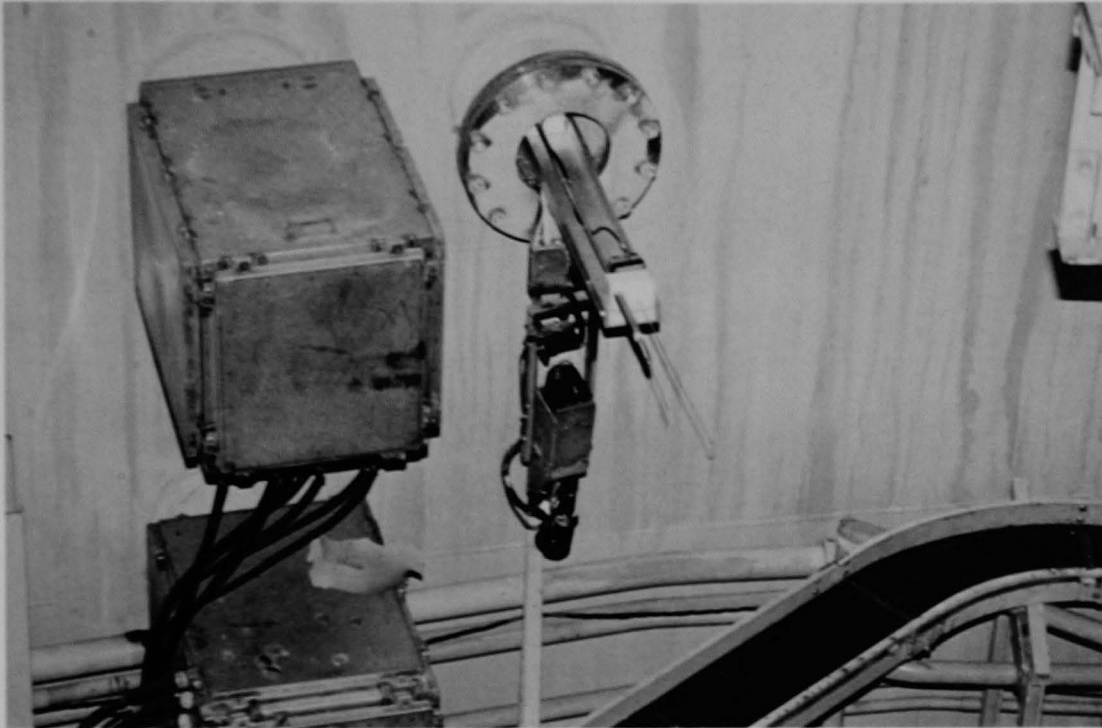

Figure 175 (4B). Penetration 626, with video camera and telemeter dosimetry antennas.



Figure 176 (4A). Incore instrumentation electrical connections, main fuel handling bridge background, closer view. (This photograph was taken to document boron crystal accumulation.)

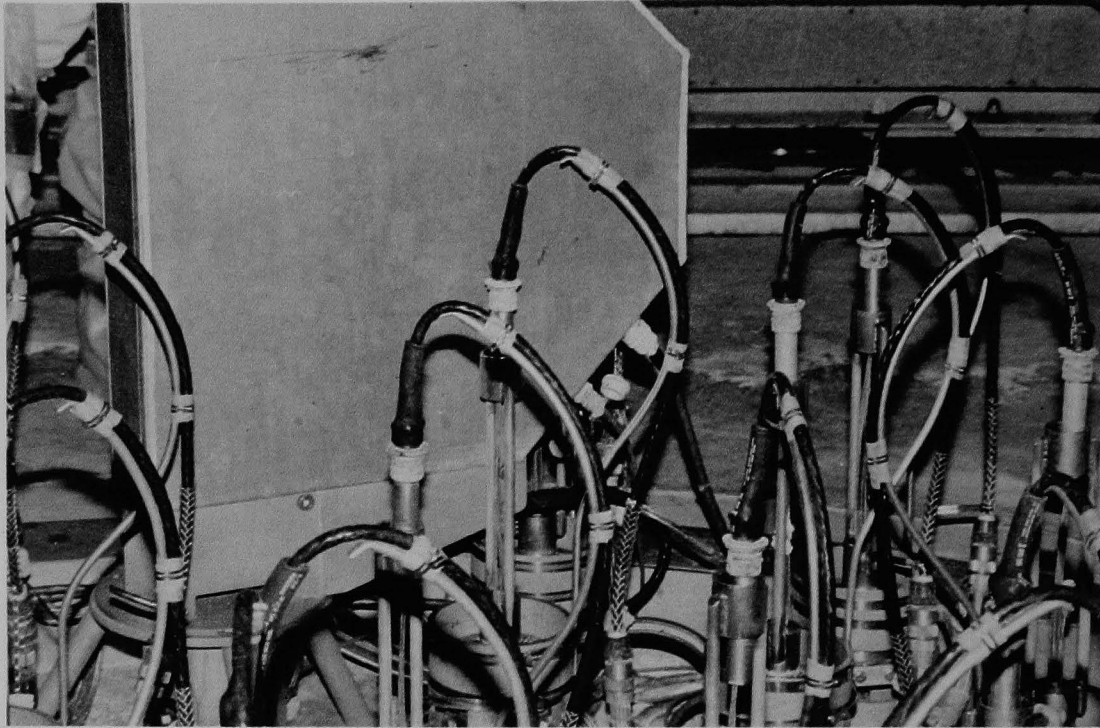

Figure 177 (4B). Incore instrumentation seal table (the metal cover houses the cable wheel for the movable incore detector. This photograph was taken to document boron crystal accumulation.)

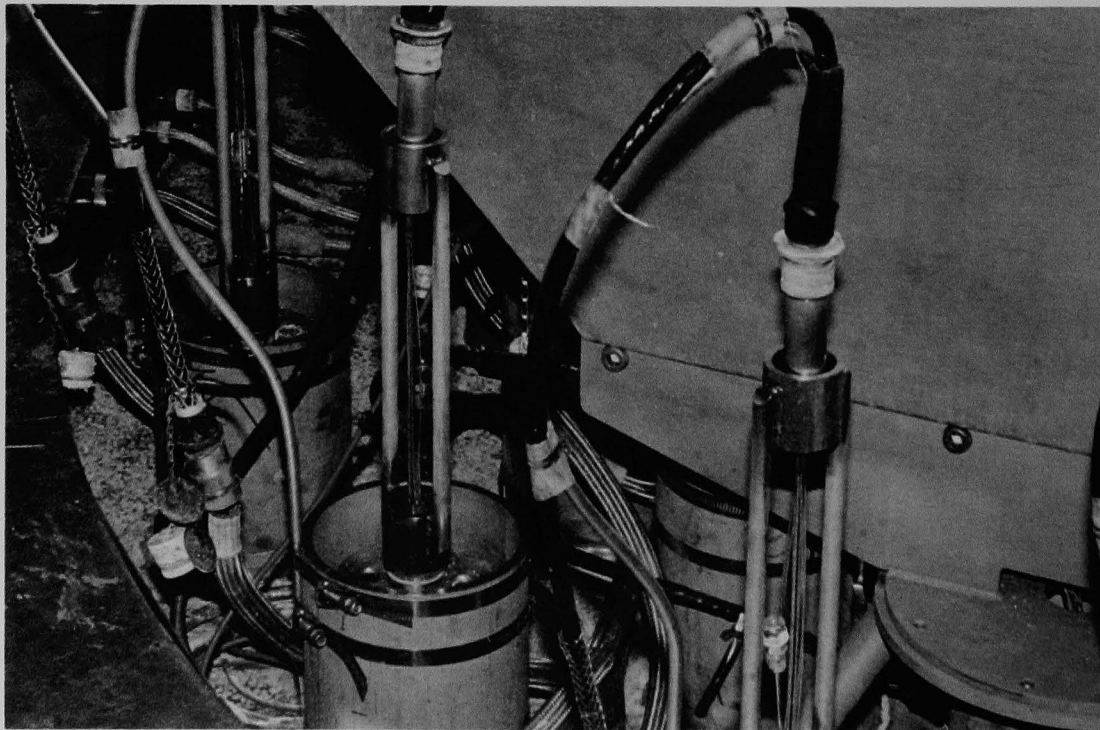

Figure 178 (4B). Incore instrumentation seal table, closer view and taken from behind metal box (cf. Figure 190).

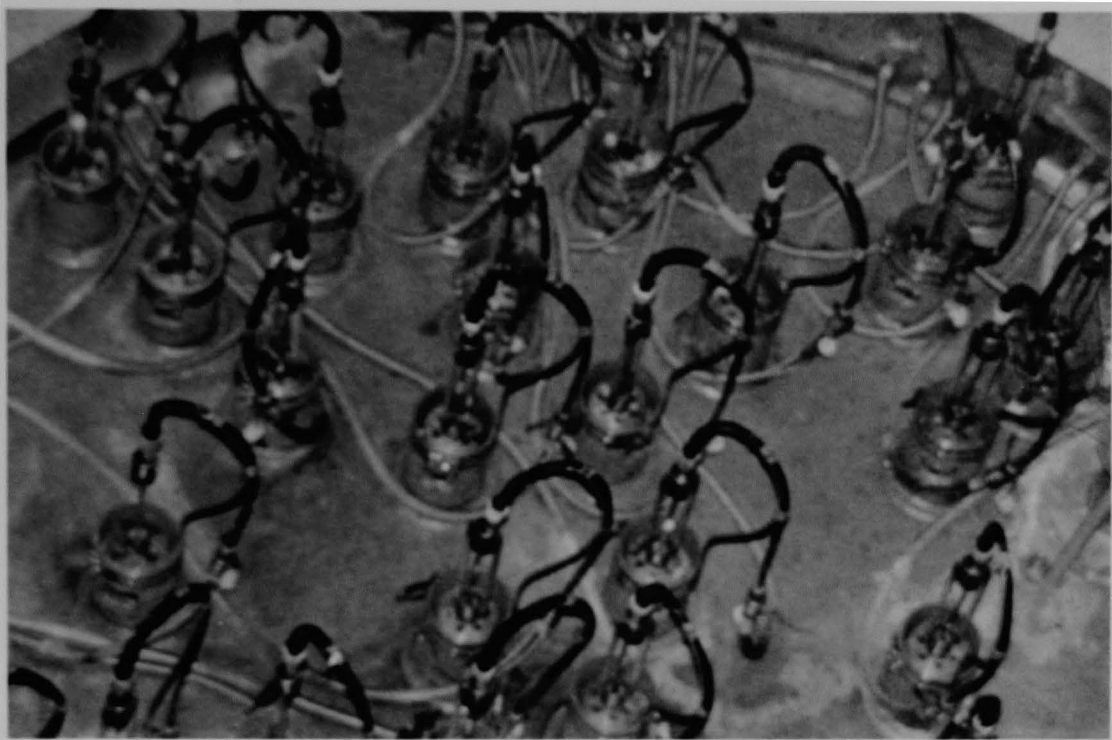

Figure 179 (4B). Incore seal table, view from above. (This photograph was taken to document boron crystal accumulation.)

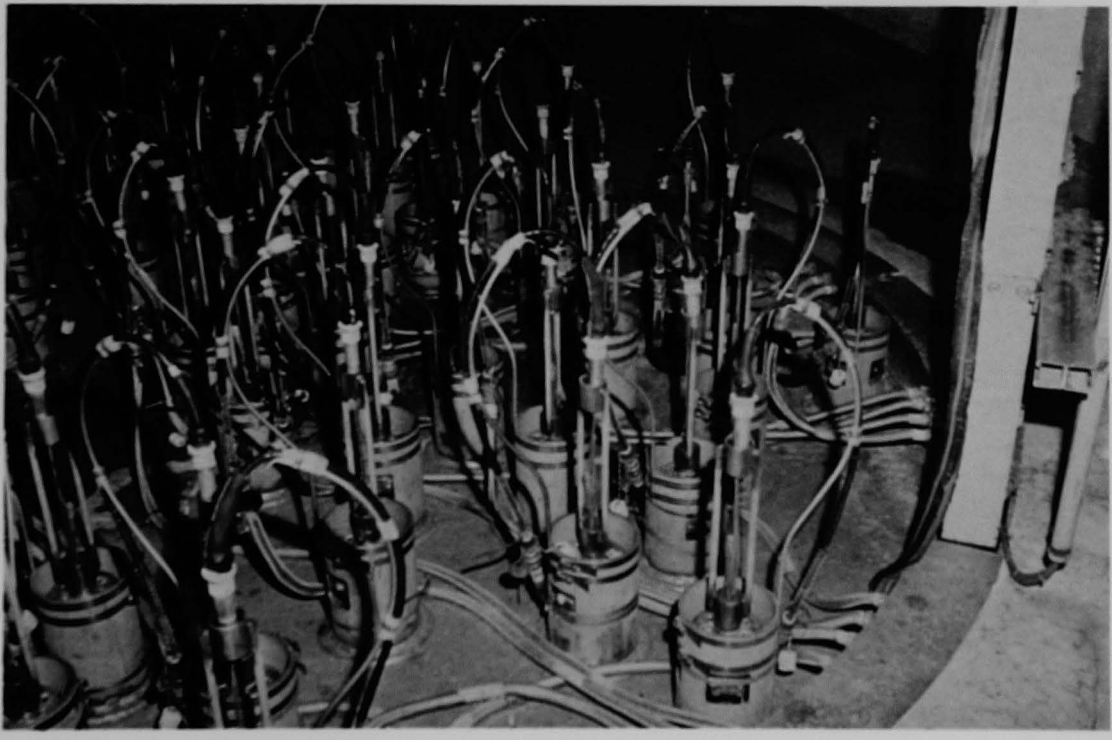

Figure 180 (4A). West side of the incore seal table. (This photograph was taken to document boron crystal accumulation.)



Figure 181 (5C). A northeast portion of the incore seal table (this photograph was taken to document boron crystal accumulation).



Figure 182 (4B). North end of the fuel pool; incore seal table background, main fuel handling bridge left.

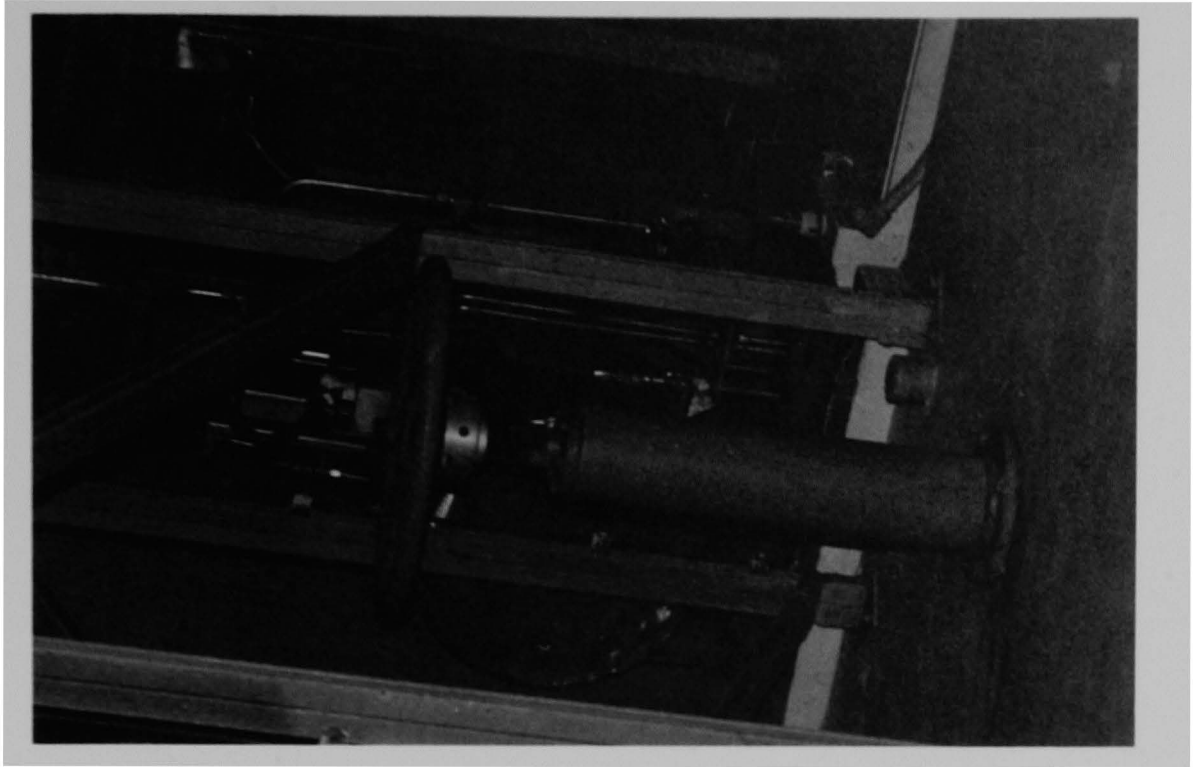

Figure 183 (4B). View of valve for supply water to the fuel pool.

ELEVATION 347

QUADRANT 4



Figure 184 (5C). East side of containment from atop the elevator. (Note that the building spray lines turn up at right.)



Figure 185 (4A). East side of D-ring B wall; air tank right center, HP technician recording survey left.

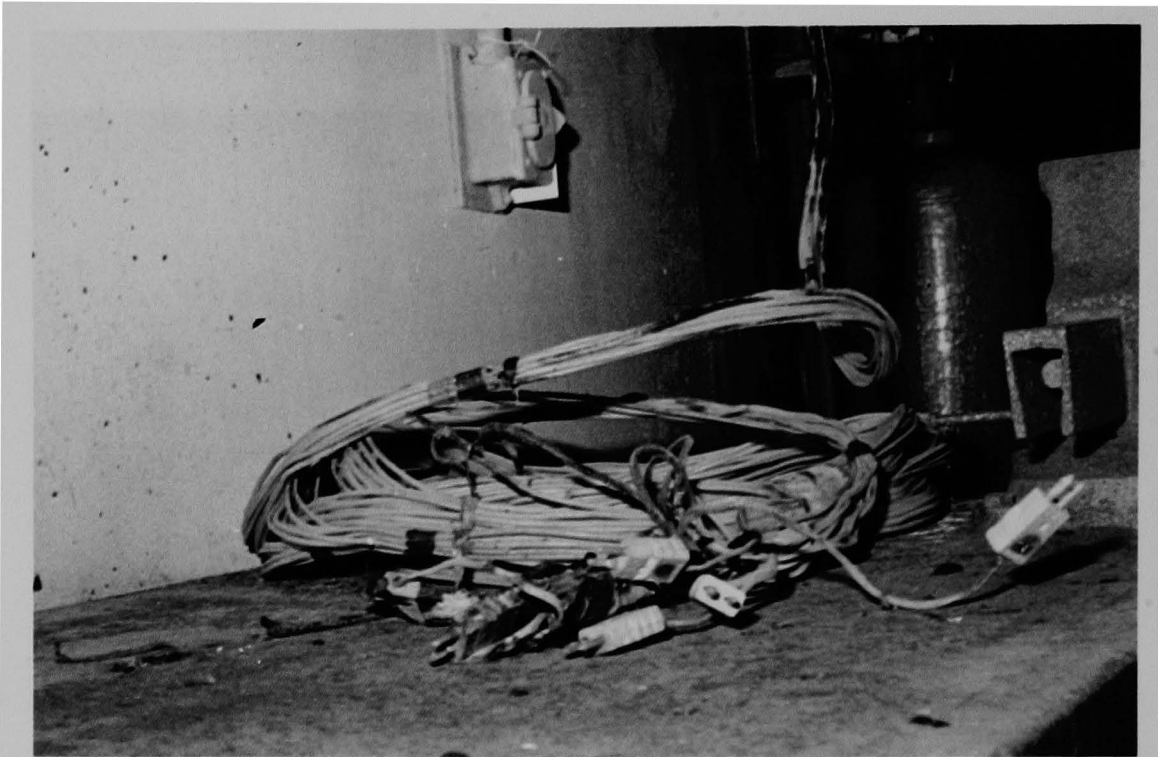

Figure 186 (4). Coil of electrical cord on work bench (see Figure 207); note blackened card and tape.

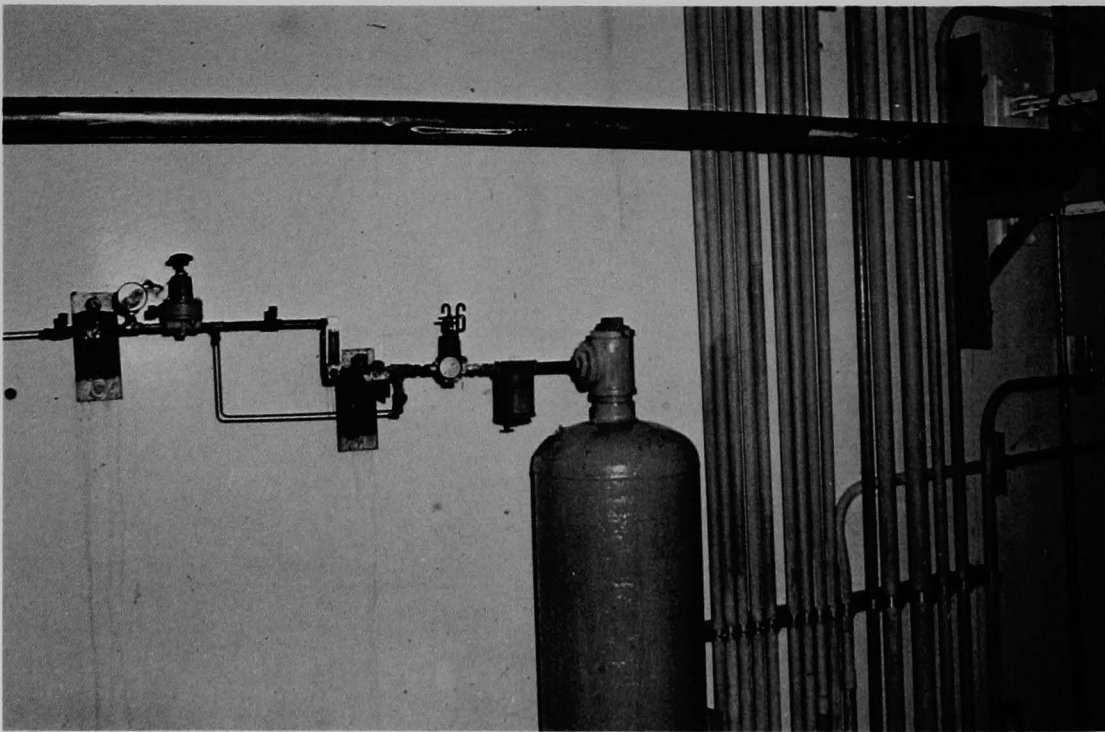

Figure 187 (4A). East side of D-ring B, showing air tank and gauges.

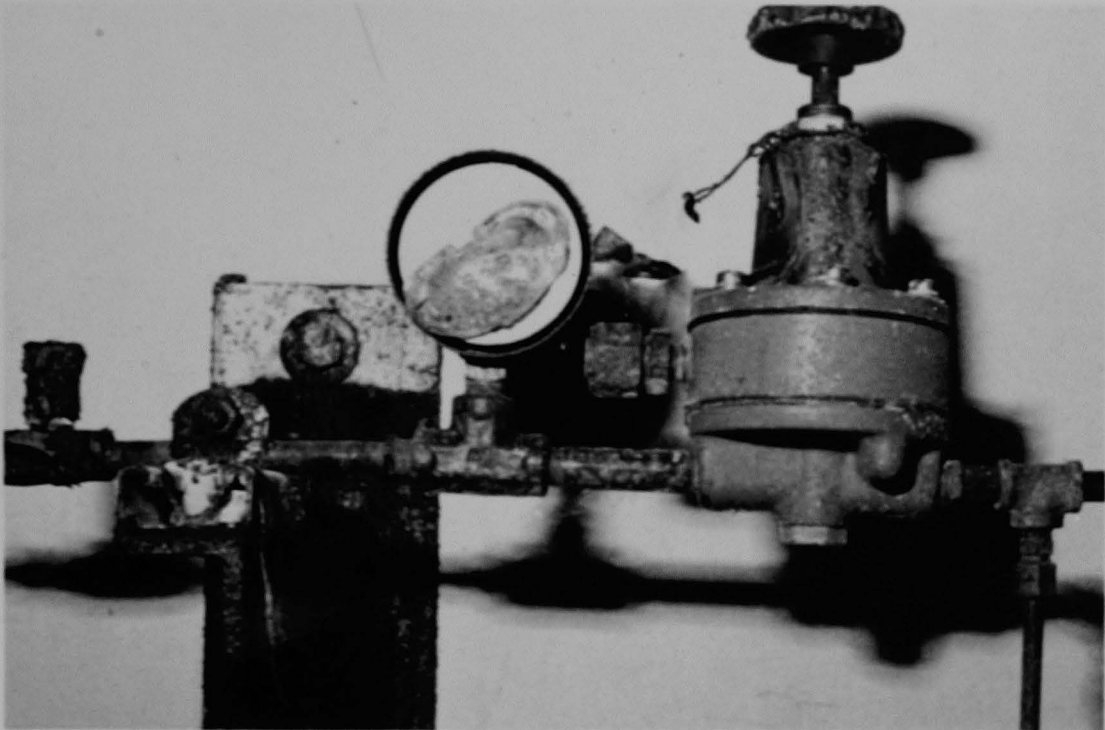

Figure 188 (4). Air pressure regulator mounted on the D-ring wall (see Figure 210) and a guage on which the lens has melted.



Figure 189 (4). Plastic wrapped equipment lying on floor near liner north of enclosed stairwell.



Figure 190 (5A). Floor penetration 266, along east side of D-ring wall.



Figure 191 (5C). Tool cabinet and boxes; purge ducting and gauges for steam generator side left, cable trays background.



Figure 192 (6A). Purge ducting and tool boxes (cf. Figure 211).

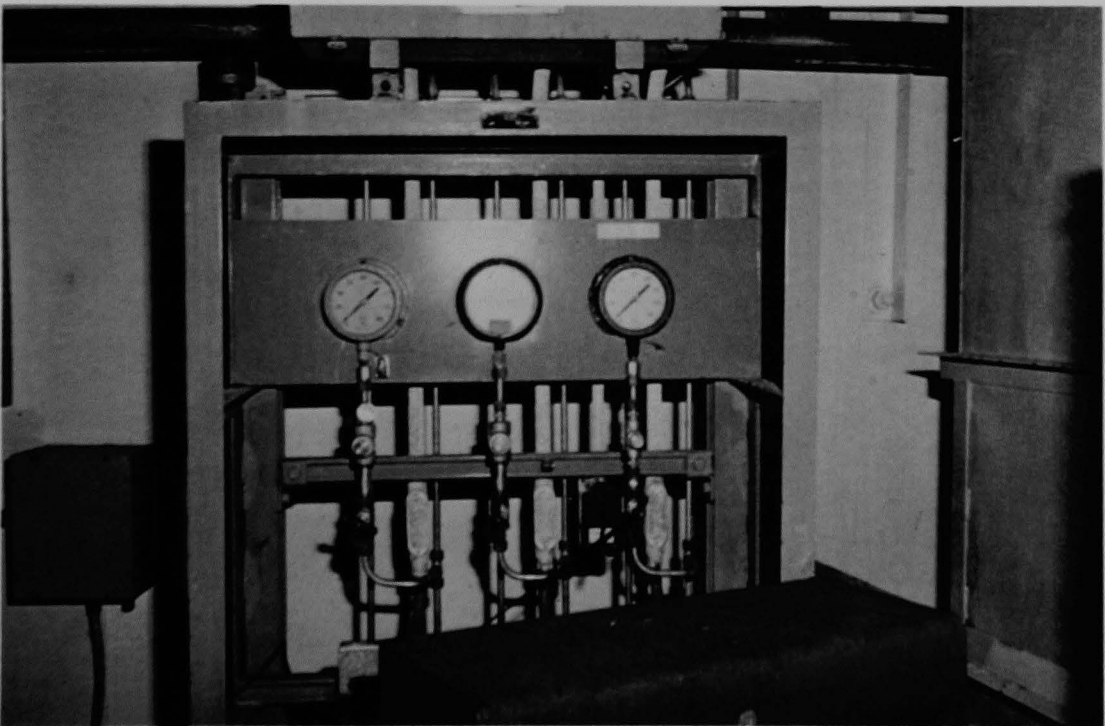

Figure 193 (4A). Gauges for steam generator secondary side; tool box foreground (see Figure 211).



Figure 194 (4A). Decking over core flood tank A; cable trays background.



Figure 195 (4B). View down the seismic gap near the hatch over core flood tank A.



Figure 196 (4). Charred radiation sign lying on the decking over core flood tank A.

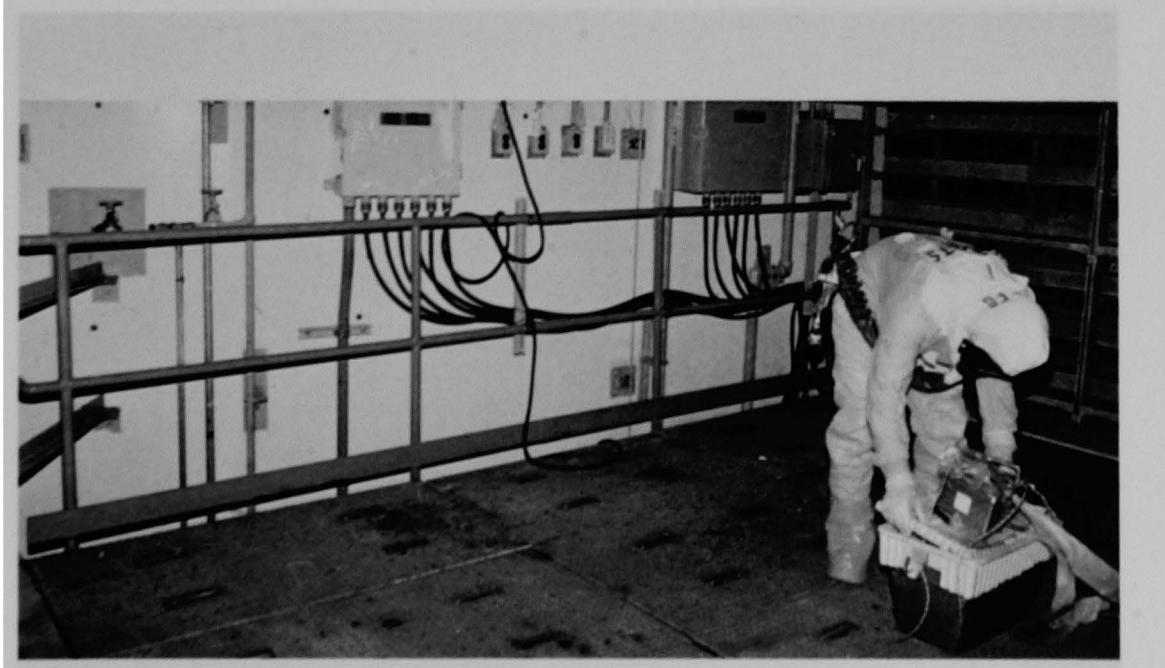

Figure 197 (5C). Technician preparing to perform decontamination tests.

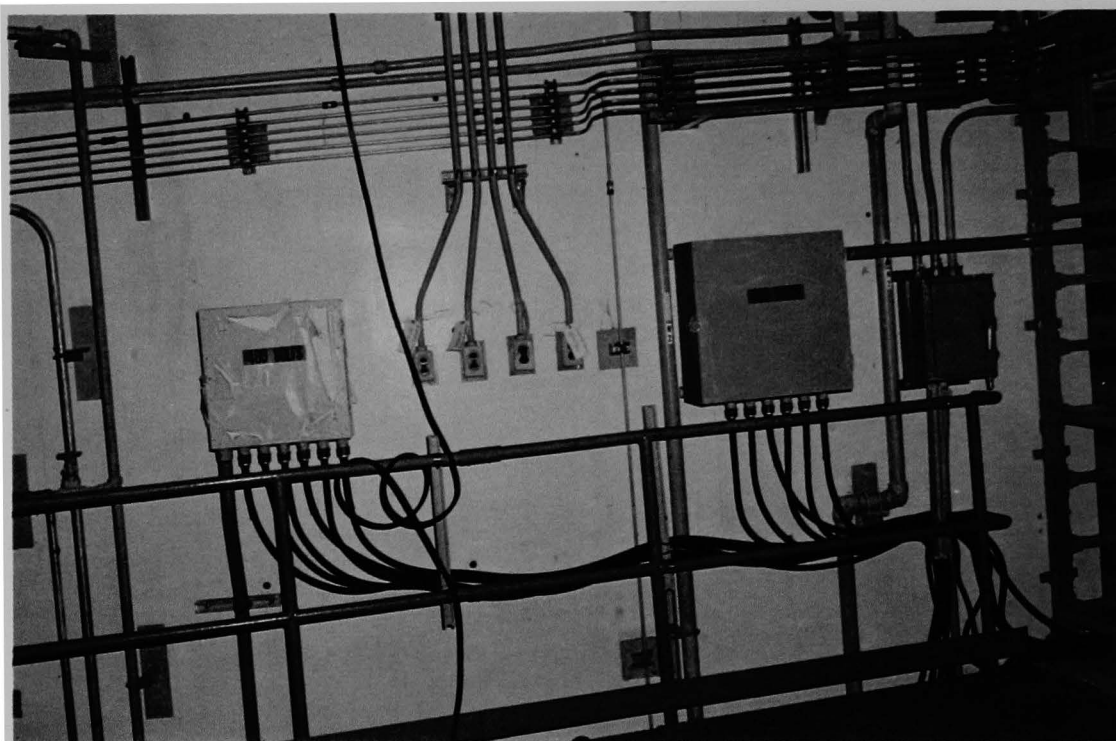

Figure 198 (4A). Energized electrical outlets.

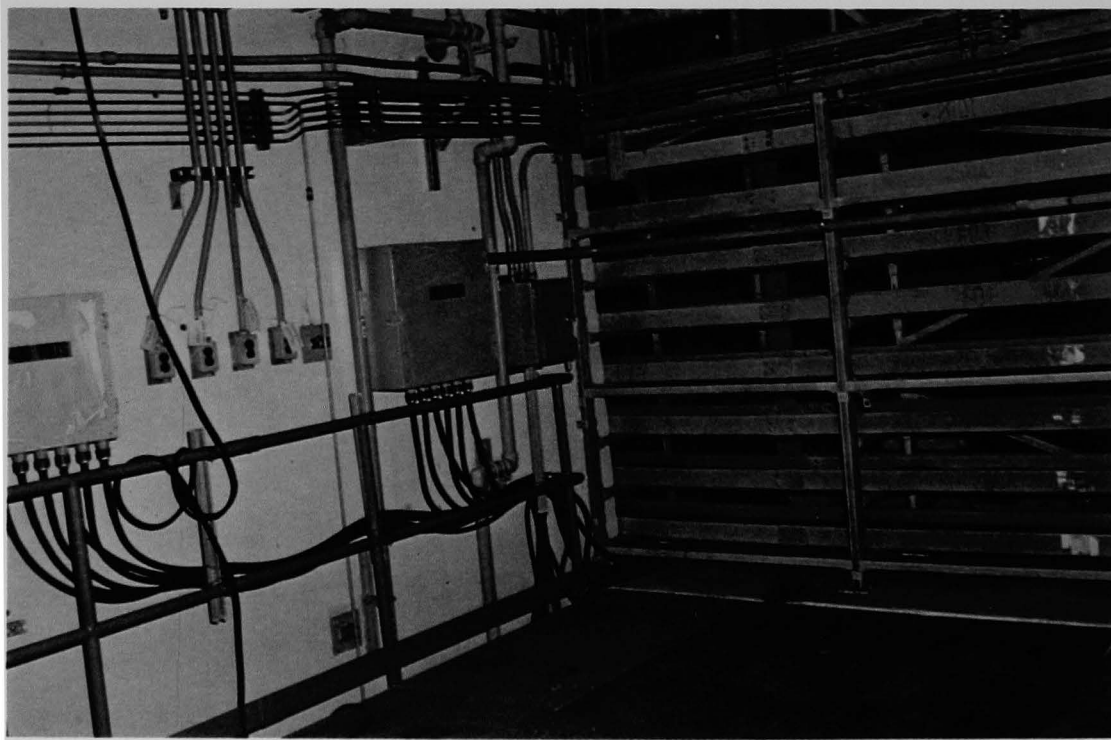

Figure 199 (4A). Energized electrical outlets and cable trays.



Figure 200 (6A). Charred manual lying on top of electrical box.

**D-RING A
AREA**



Figure 201 (5B). Top of D-ring A, and missile shields over the reactor vessel.

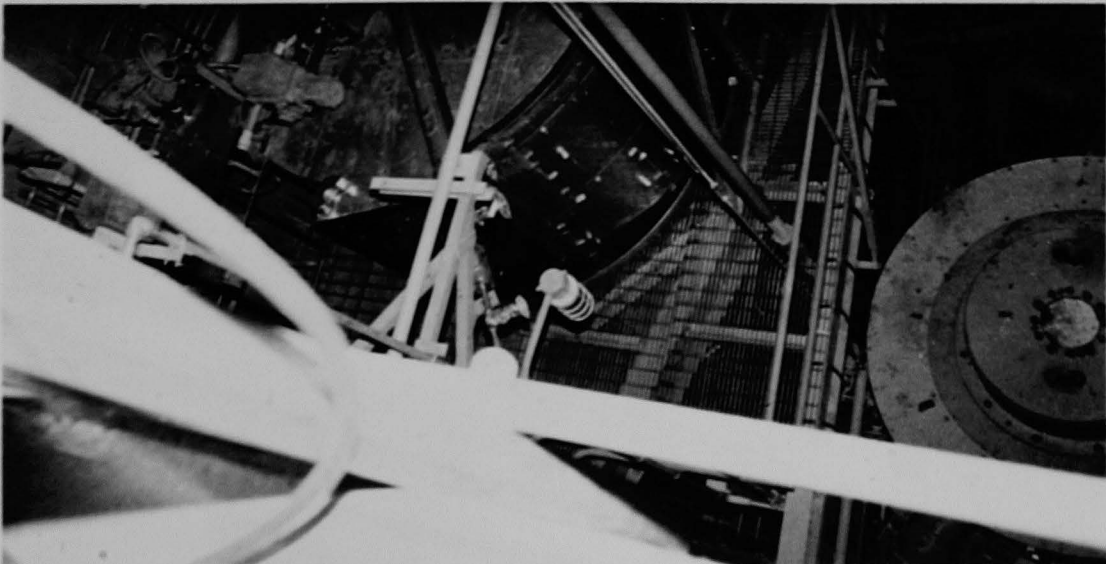

Figure 202 (5C). Pressurizer from top of D-ring A; reactor coolant pump right.

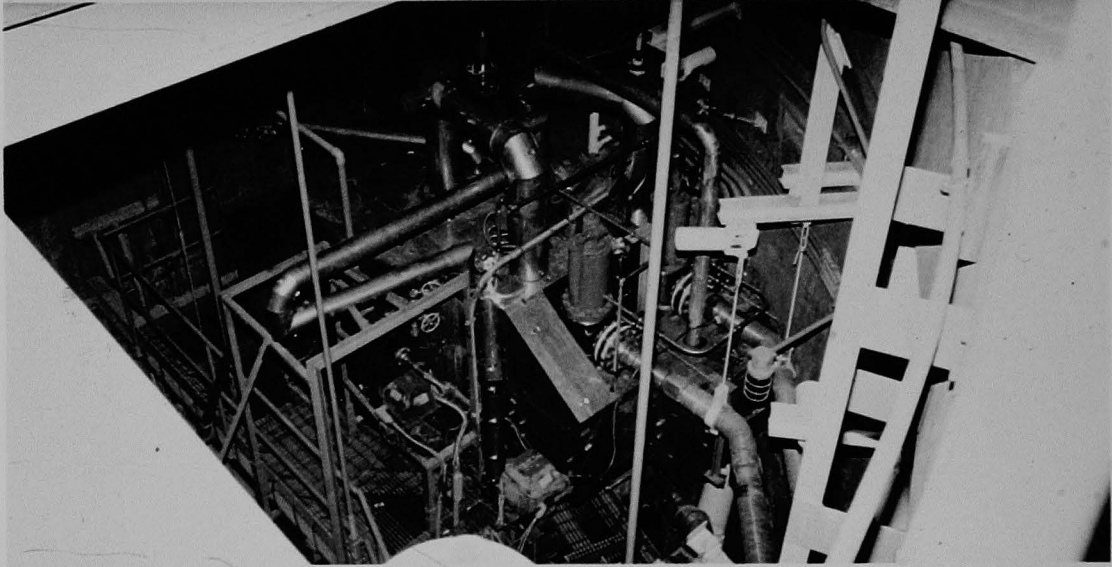

Figure 203 (5C). Pressurizer, first view from northwest.

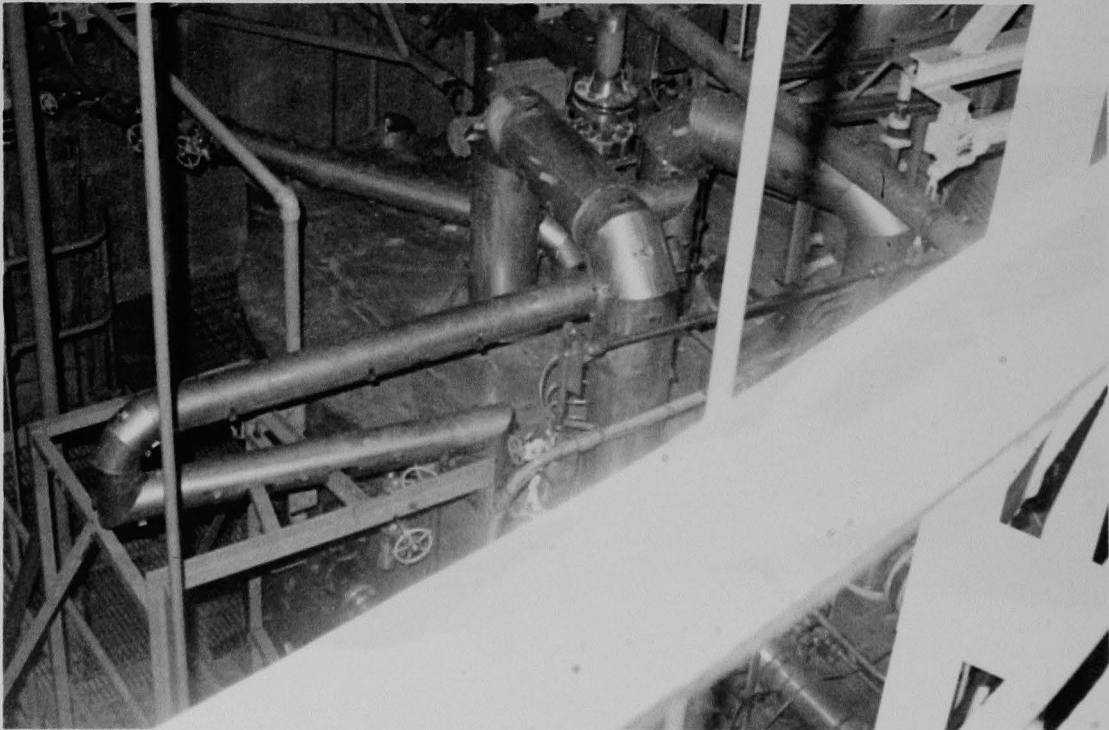

Figure 204 (4). Pressurizer, second view from northwest.

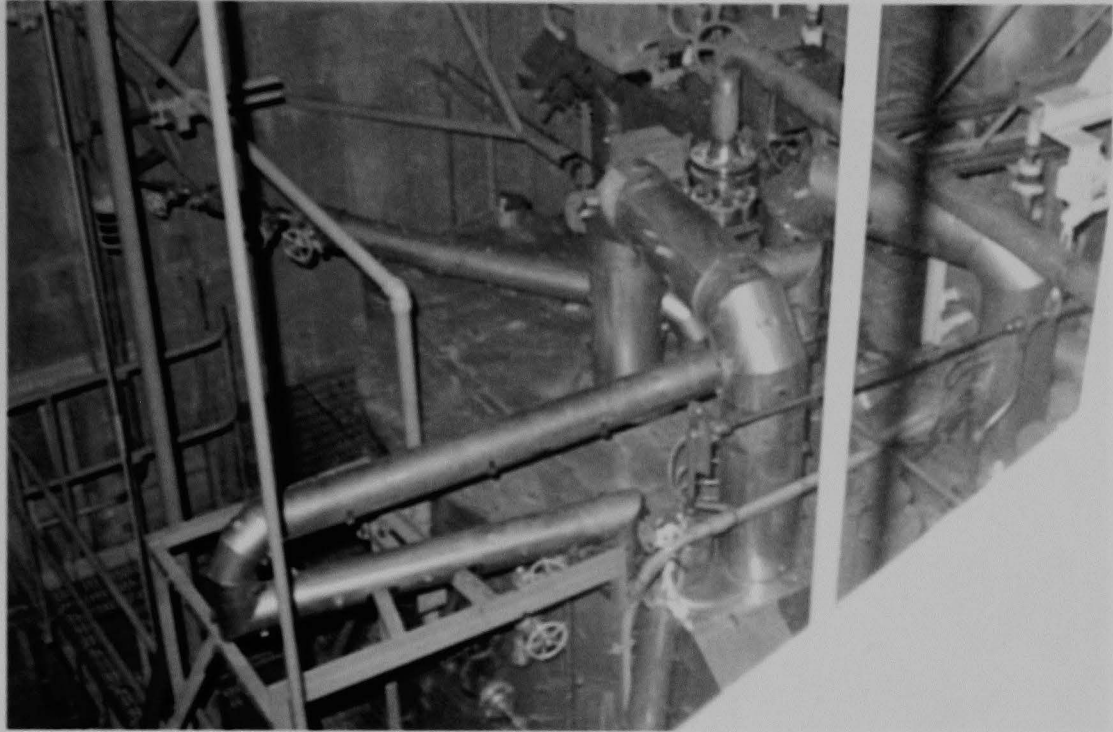

Figure 205 (4). Pressurizer, third view from northwest.

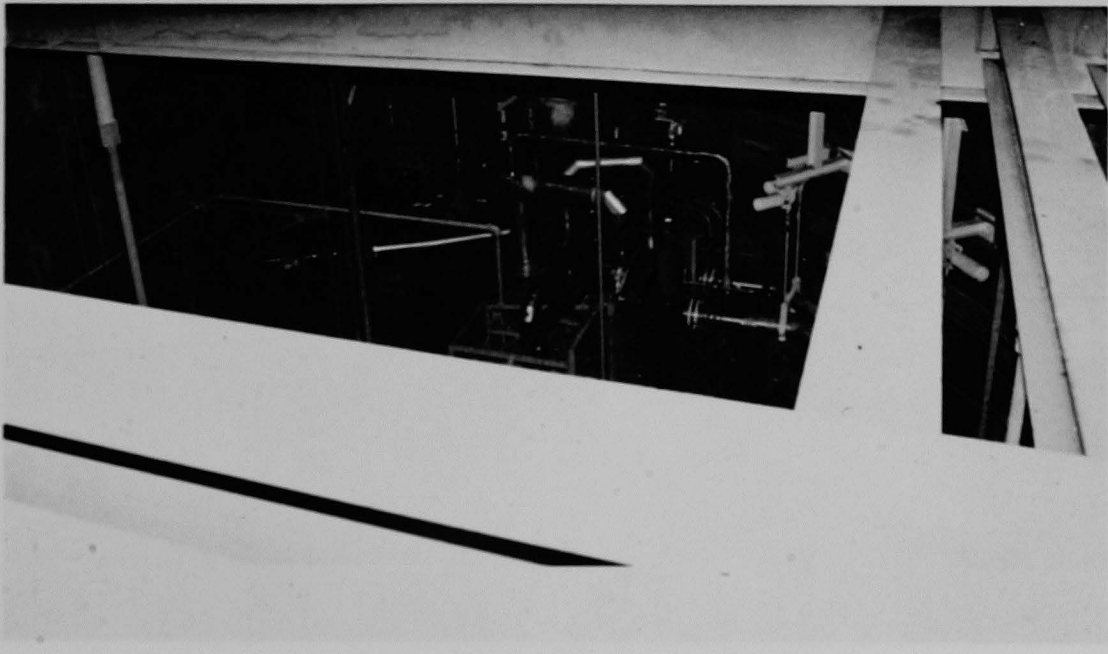

Figure 206 (5C). Pressurizer, fourth view from northwest.

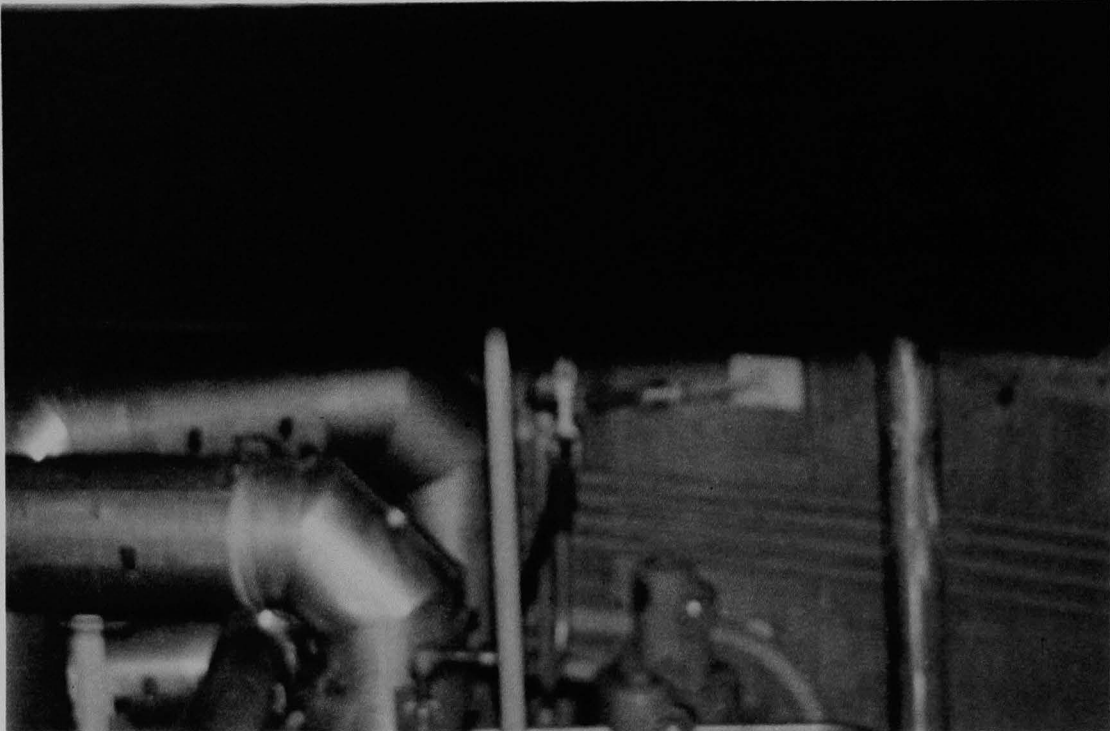

Figure 207 (4B). Pipes leading to the pressurizer (see Figure 204 center).

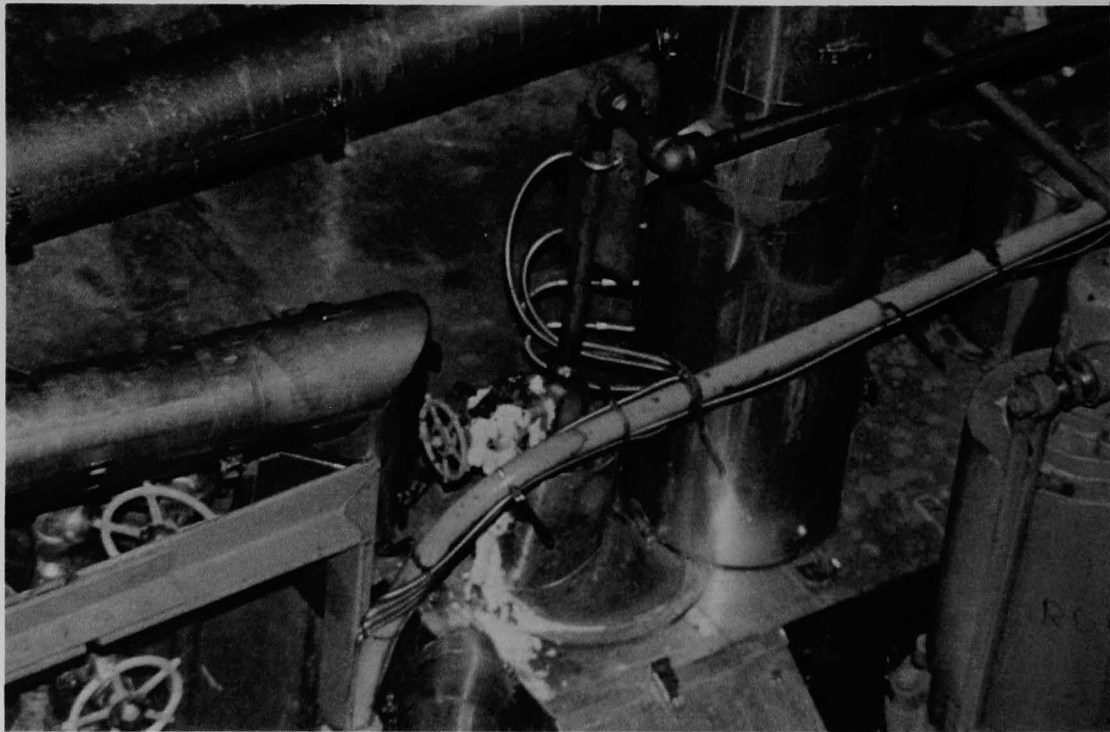

Figure 208 (4B). Valves and pipes above pressurizer (cf. Figure 178). The photograph was taken to document boron crystal accumulation.



Figure 209 (4B). Valves and pipes associated with pressurizer (see Figure 204 left center). The photograph was taken to document boron crystal accumulation.

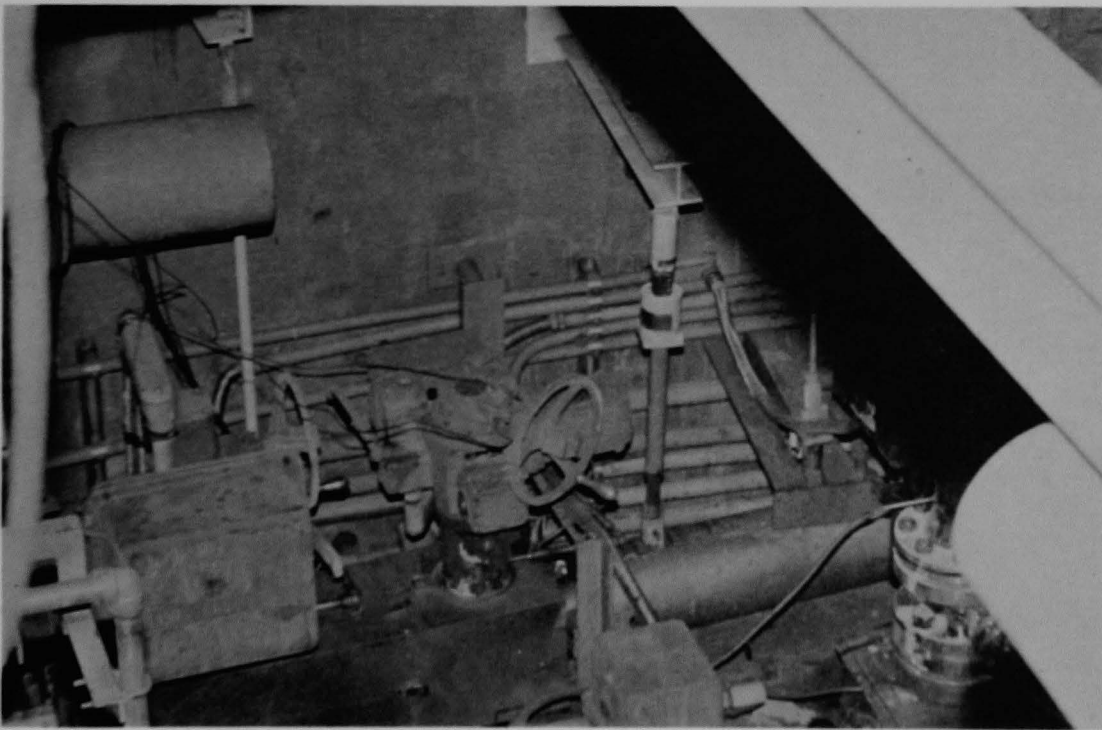

Figure 210 (4B). Pressure-operated release valve above the pressurizer. (The photograph was taken to document boron crystal accumulation).



Figure 211 (4B). Inside D-ring A near the pressurizer.

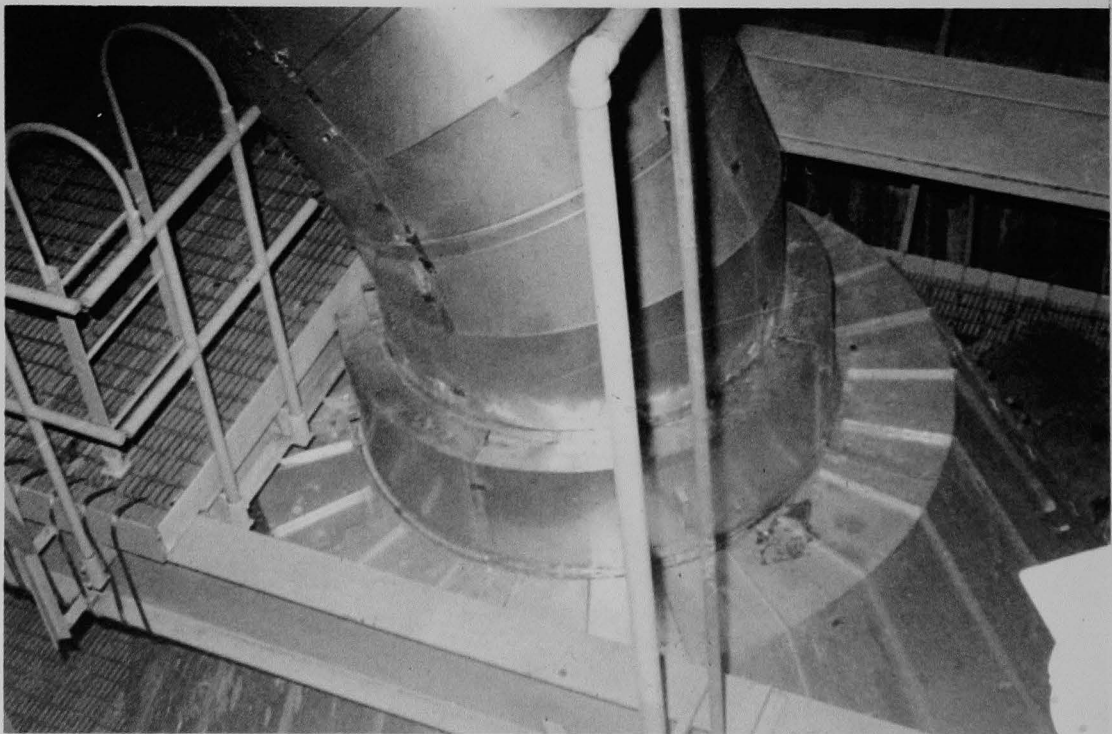

Figure 212 (4). Top of steam generator A from northwest.

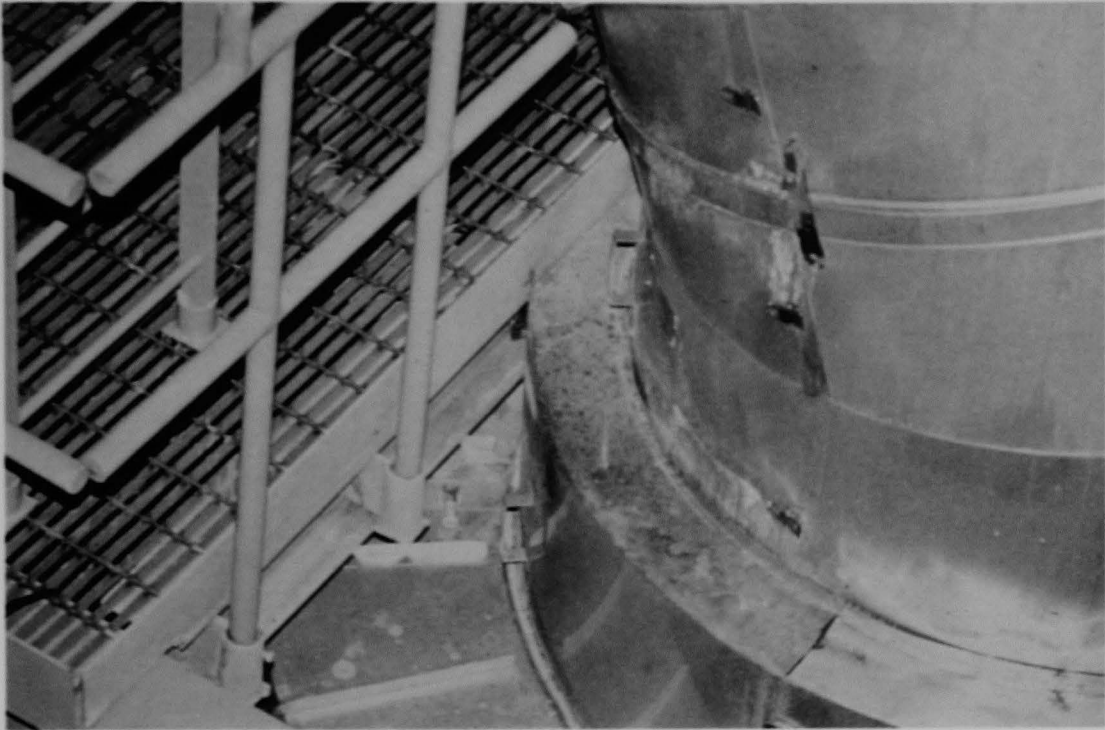

Figure 213 (4B). Close-up of the top of steam generator A.

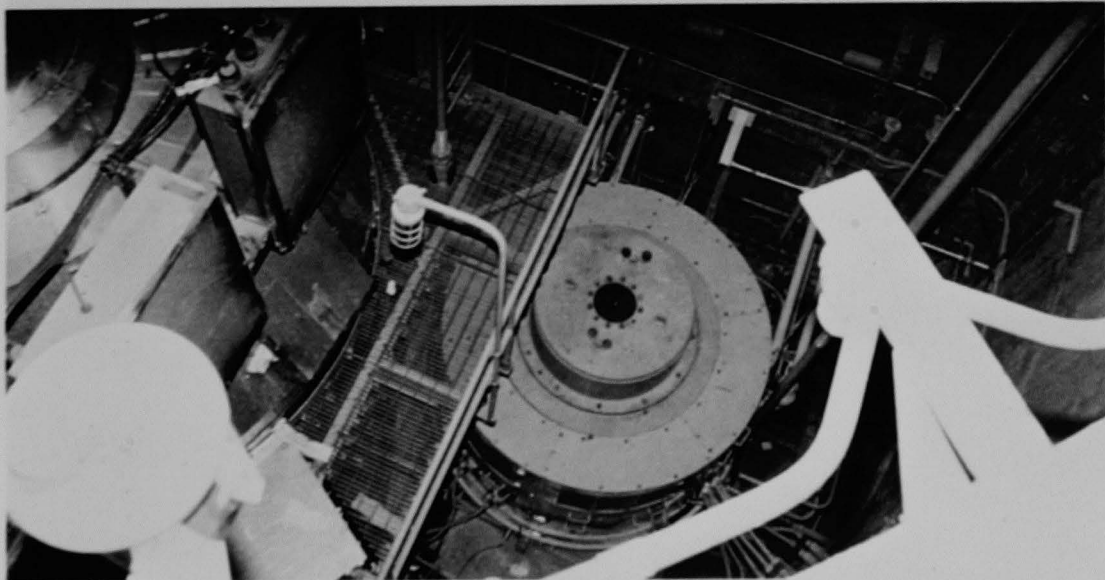

Figure 214 (5C). Steam generator and reactor coolant pump, view from atop D-ring.

CRANE ELEVATIONS



Figure 268 (4B). Access platform to the polar crane; containment spray lines left.



Figure 269 (5B). Close-up of the access platform to the polar crane.

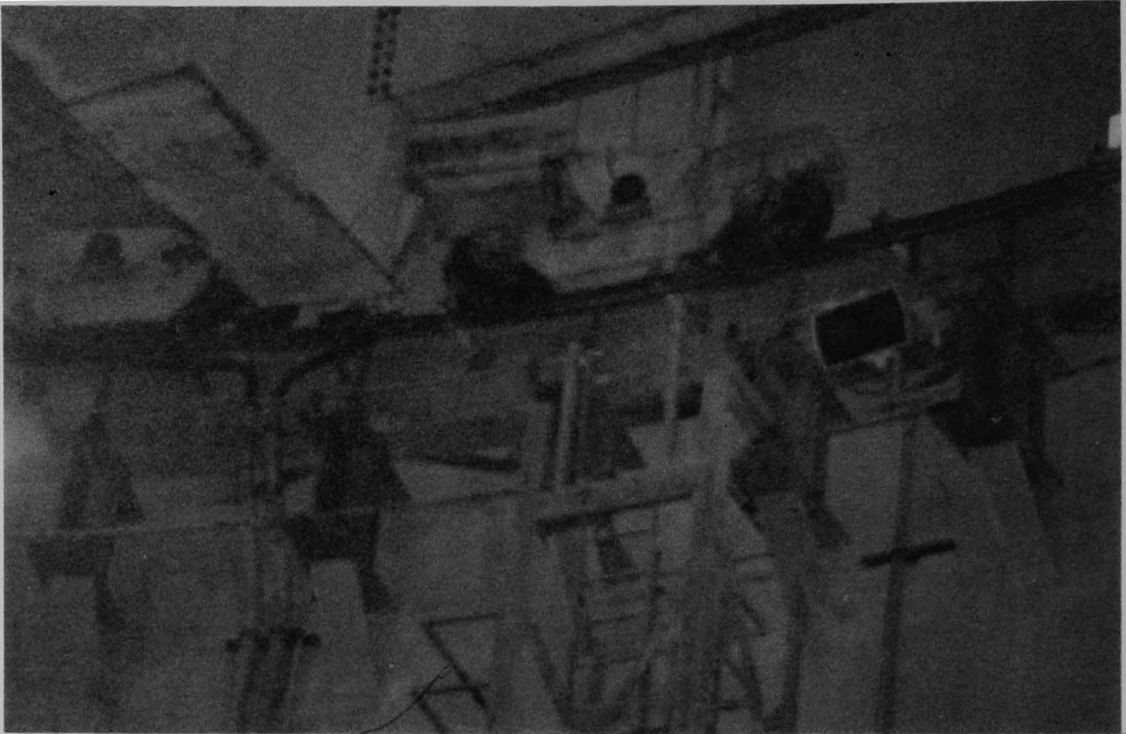

Figure 270 (4B). East side of polar crane near access platform.



Figure 271 (6A). Ventilation duct on the containment wall, southwest quadrant.

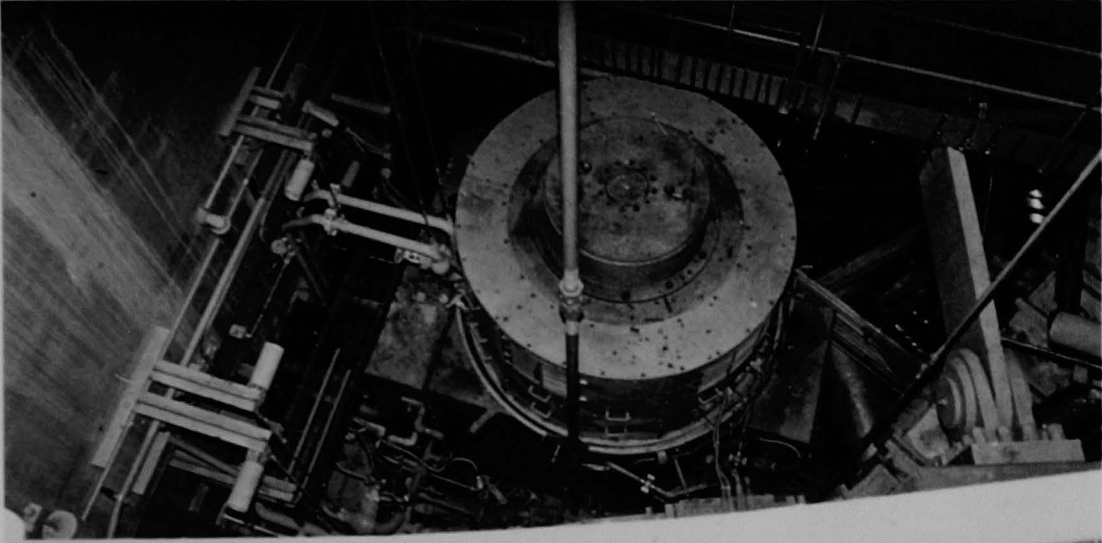

Figure 219 (5C). Reactor coolant pump inside D-ring B.

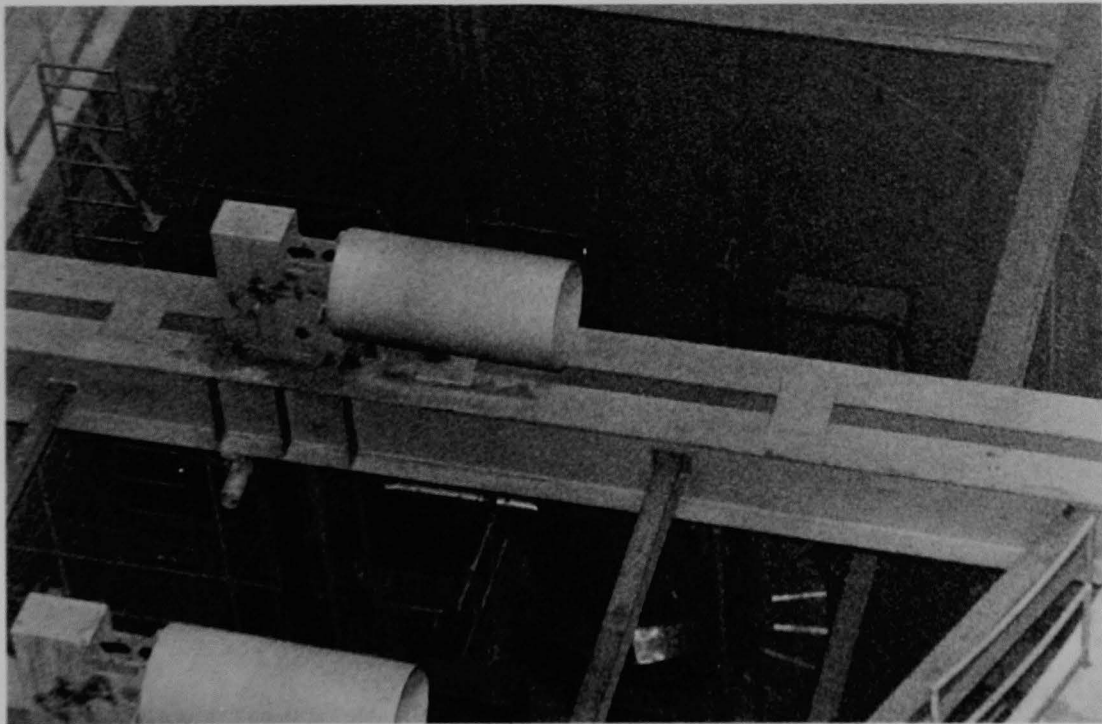

Figure 220 (5B). View down into D-ring B showing seismic support for equipment.

FUEL POOL AREA



Figure 221 (2B). Auxiliary fuel handling bridge.

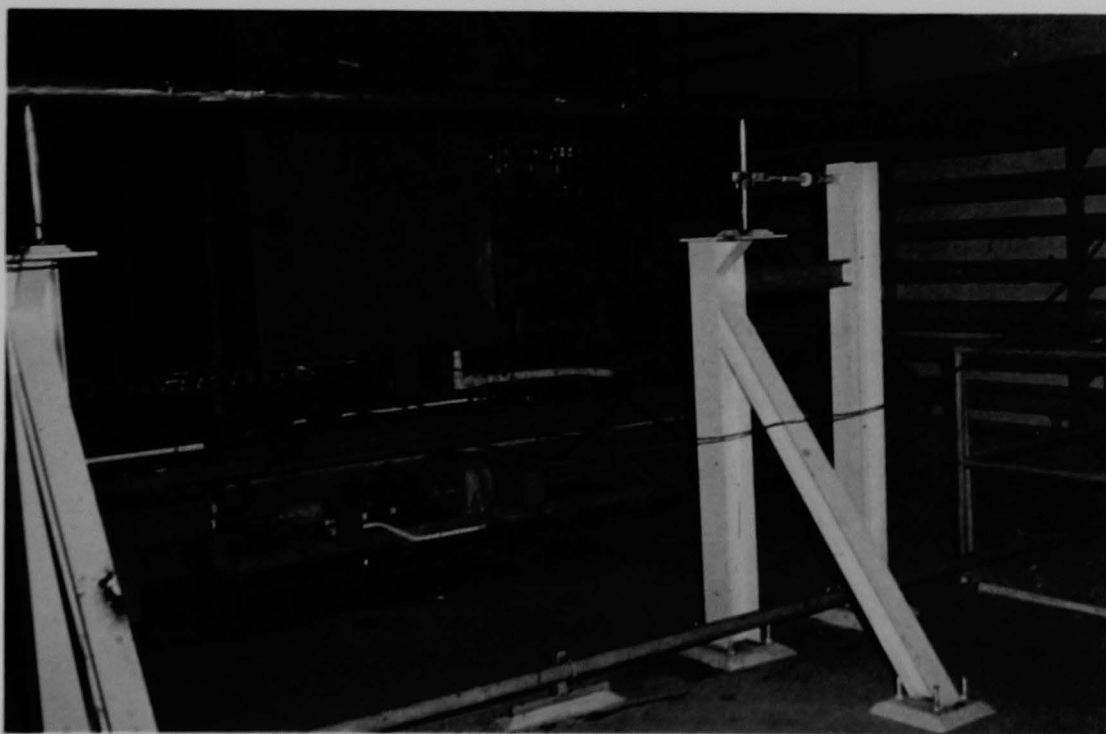

Figure 222 (4A). Power track and bridge motor of auxiliary fuel handling bridge.



Figure 223 (2A). Power track and bridge motor of auxiliary fuel handling bridge, view from southeast, with HP technicians.



Figure 224 (5B). Rusted coupling and motor on auxiliary fuel handling bridge (see Figure 222).



Figure 225 (5C). Reactor vessel and auxiliary fuel handling bridge from atop west D-ring; HP technician taking survey behind neutron shield tank.

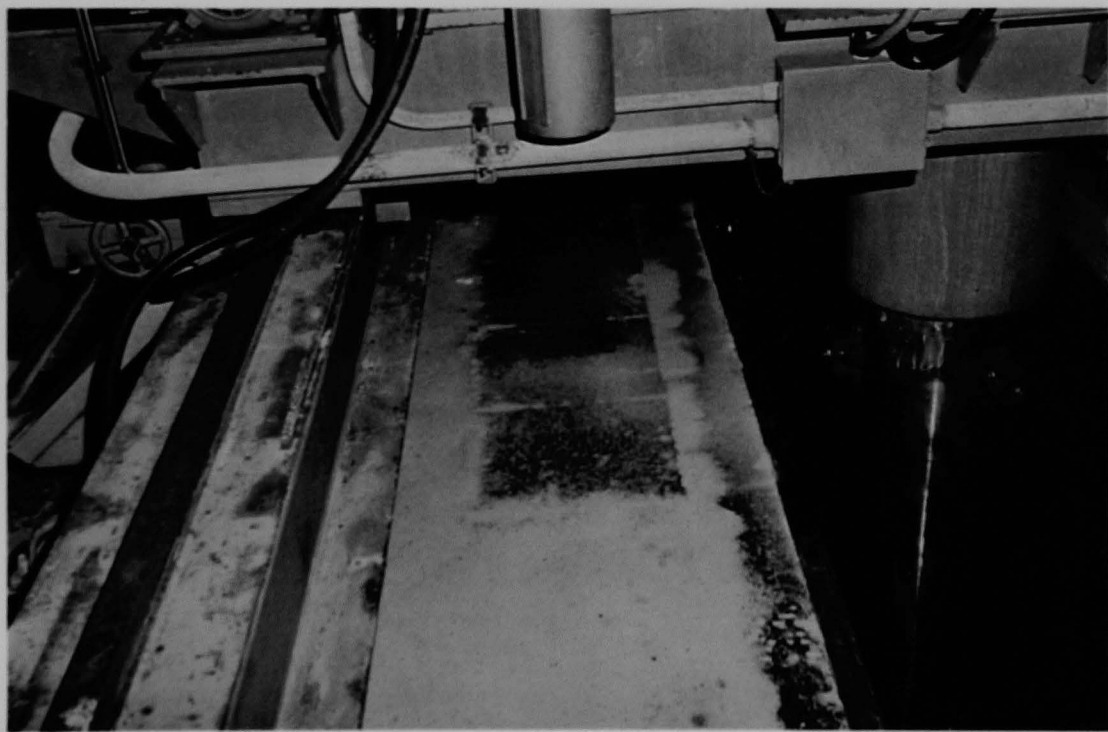

Figure 226 (4A). Lower east end of auxiliary fuel handling bridge.

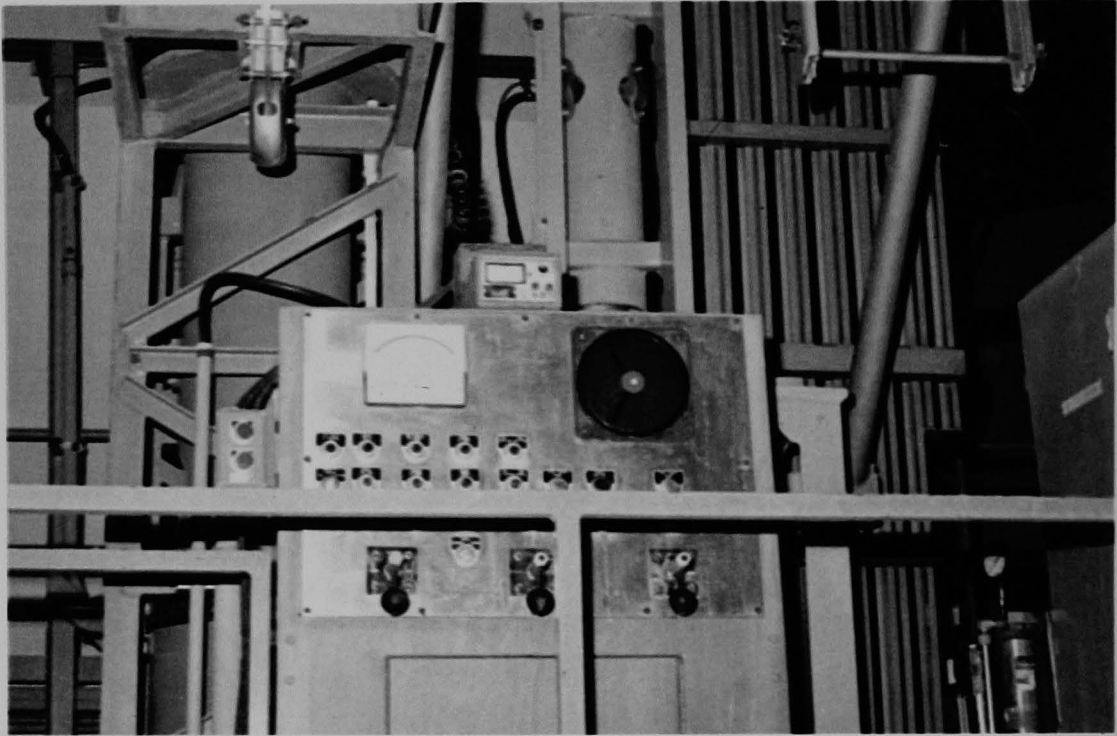

Figure 231 (4). Operator's panel on the auxiliary fuel handling bridge.

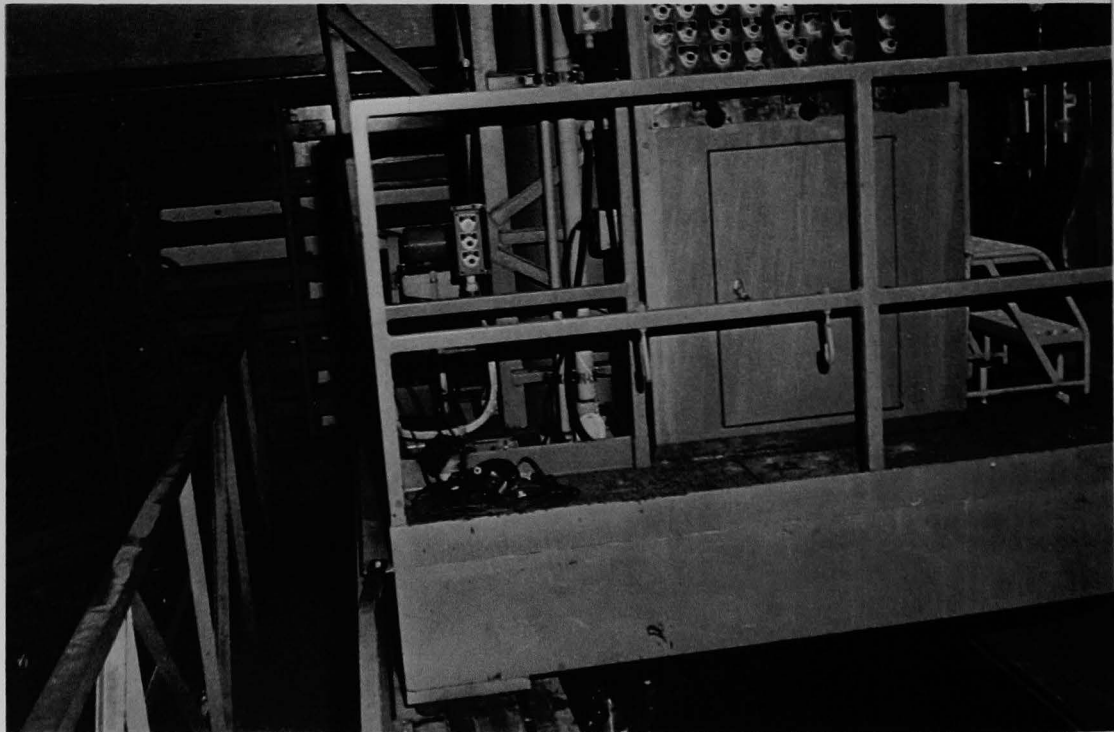

Figure 232 (4A). Auxiliary fuel handling bridge, view from northwest.



Figure 233 (5B). Charred operator's manual lying at the base of the auxiliary fuel handling bridge control panel.

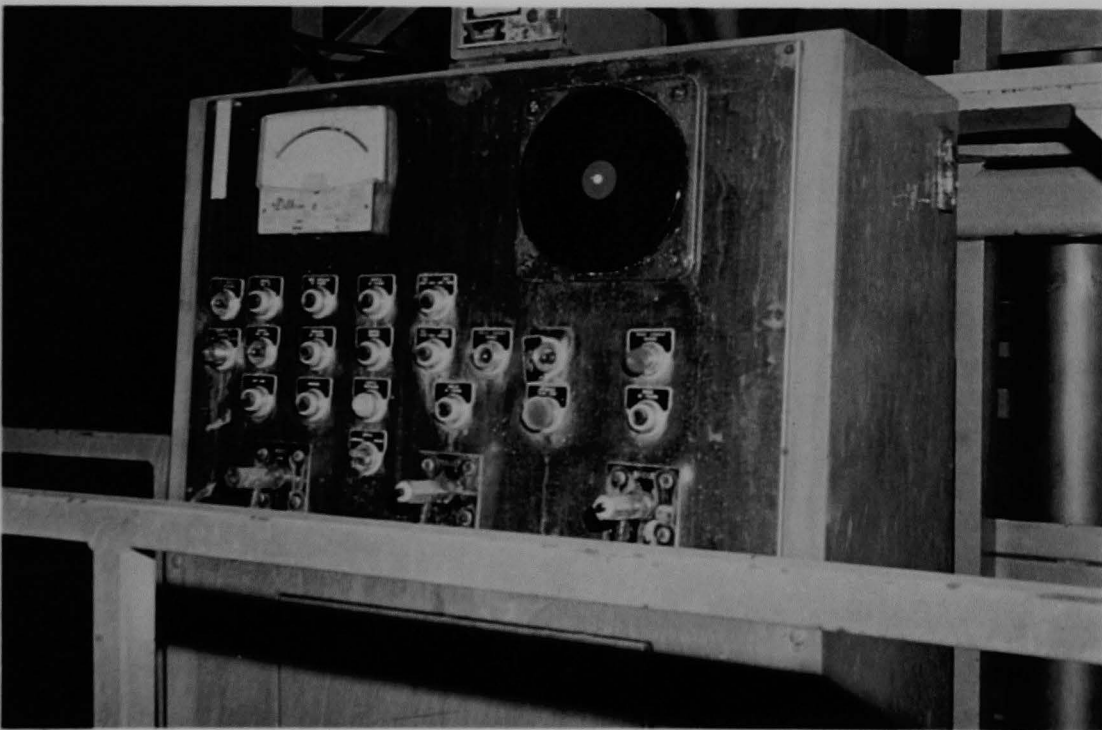

Figure 234 (6A). Operator's panel on the auxiliary fuel handling bridge, second or closer view.

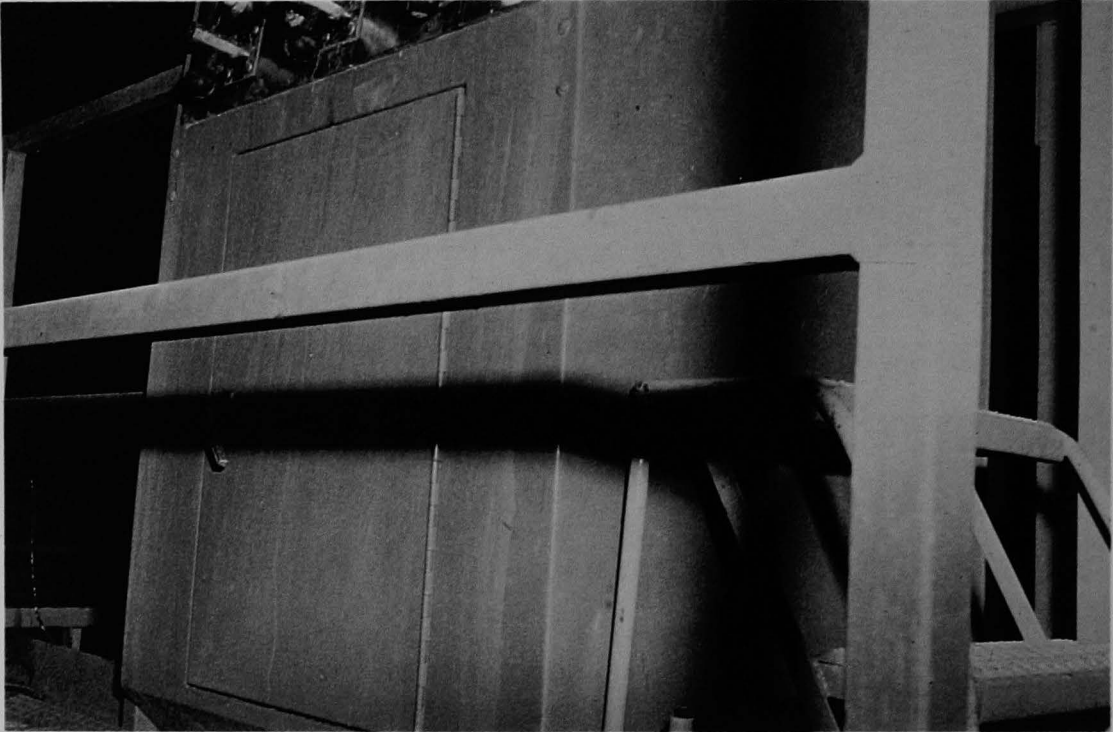

Figure 235 (6A). Lower portion of the control panel on the auxiliary fuel handling bridge.

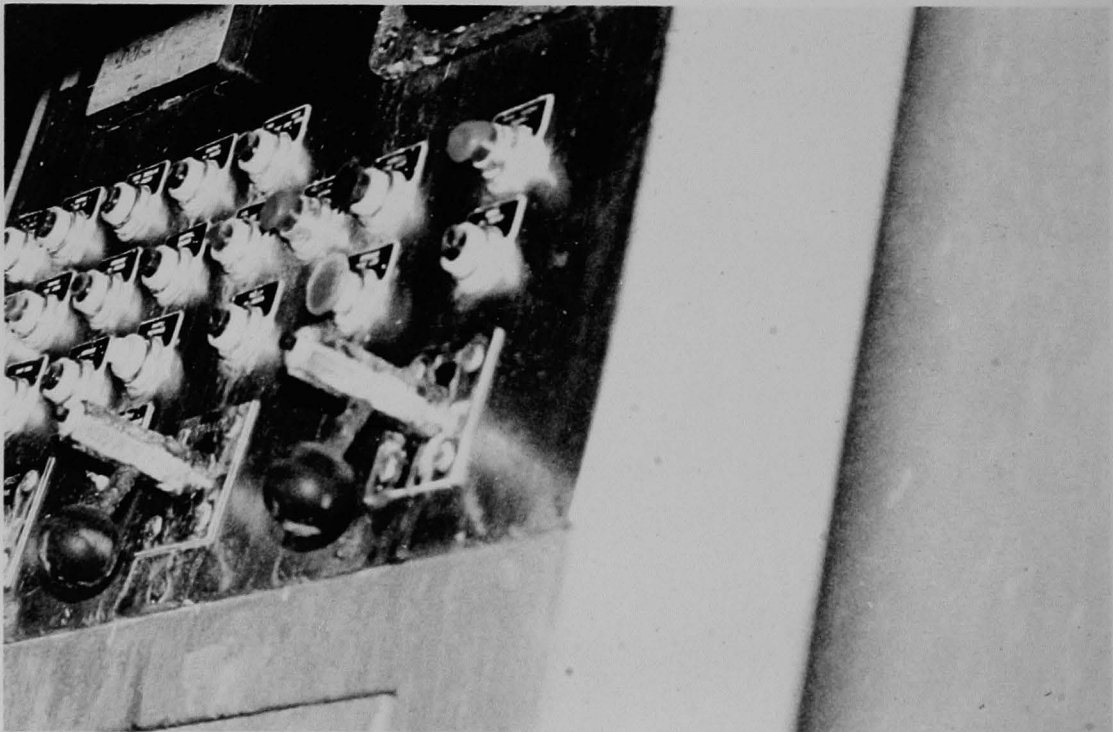

Figure 236 (5B). Close-up of the control panel on the auxiliary fuel handling bridge, first view.



Figure 237 (5B). Close-up of the control panel on the auxiliary fuel handling bridge, second view.

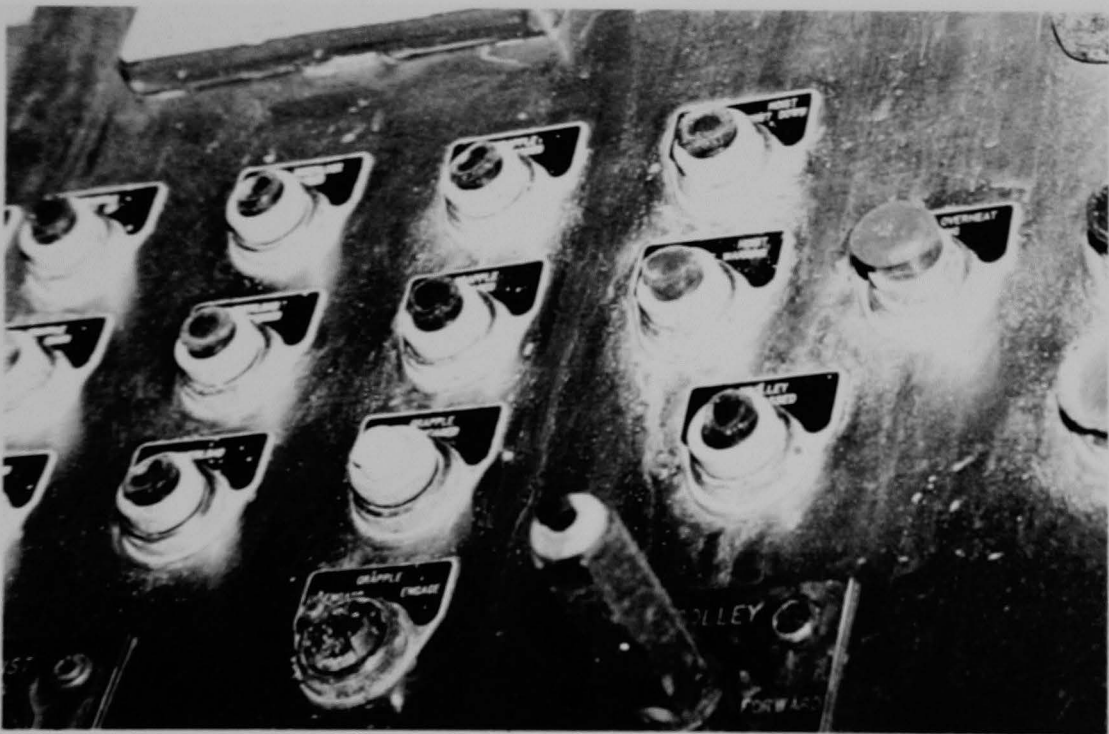

Figure 238 (5B). Close-up of the control panel on the auxiliary fuel handling bridge, third view.

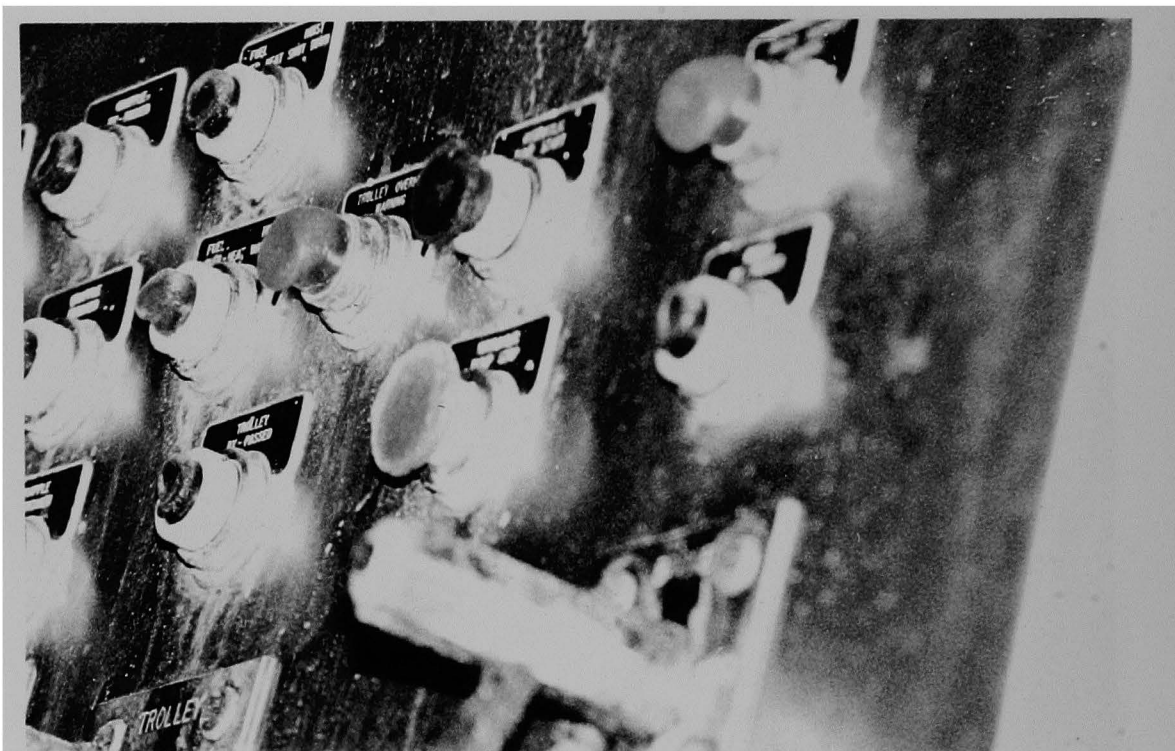

Figure 239 (5B). Close-up of the control panel on the auxiliary fuel handling bridge, fourth view.

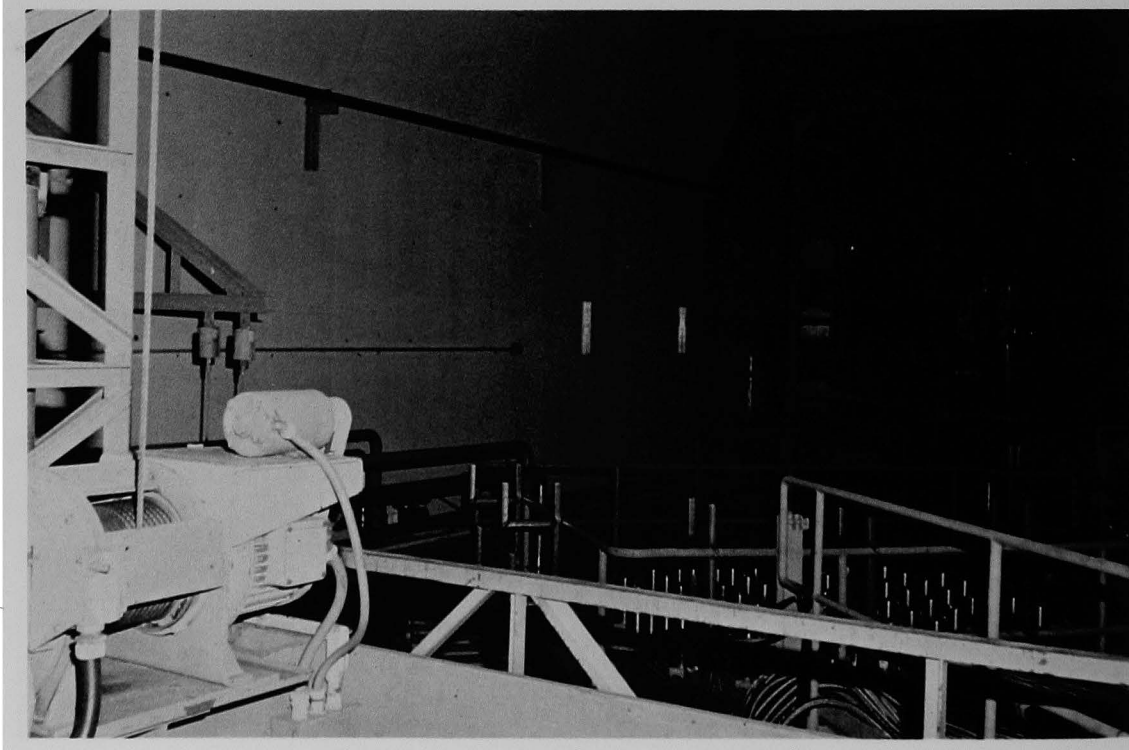

Figure 240 (2A). Top of the control rod drive mechanism (CRDM) platform above the reactor vessel; auxiliary fueling handling bridge foreground, main fuel handling bridge background right, first view.



Figure 241 (2A). Control rod drive mechanism platform and power cables; main fuel handling bridge background, second view.



Figure 242 (2A). CRDM platform and incoming power cables, third view.

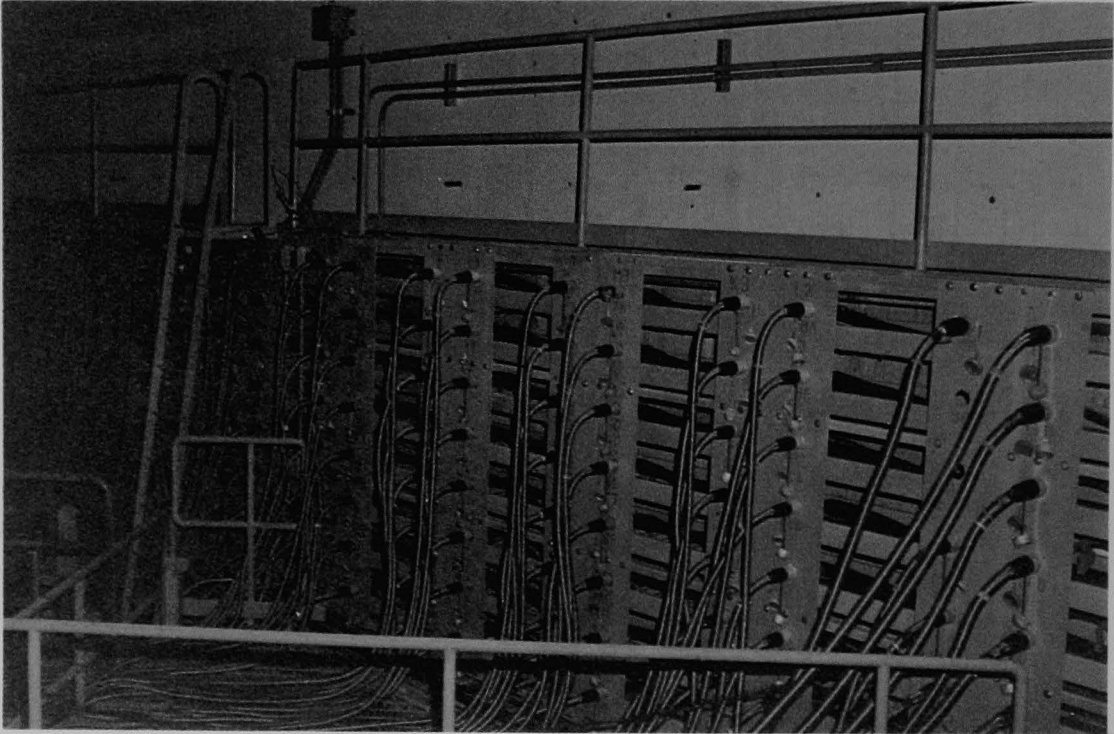

Figure 247 (6A). CRDM cable trays along D-ring B; walkway above, access ladder left.

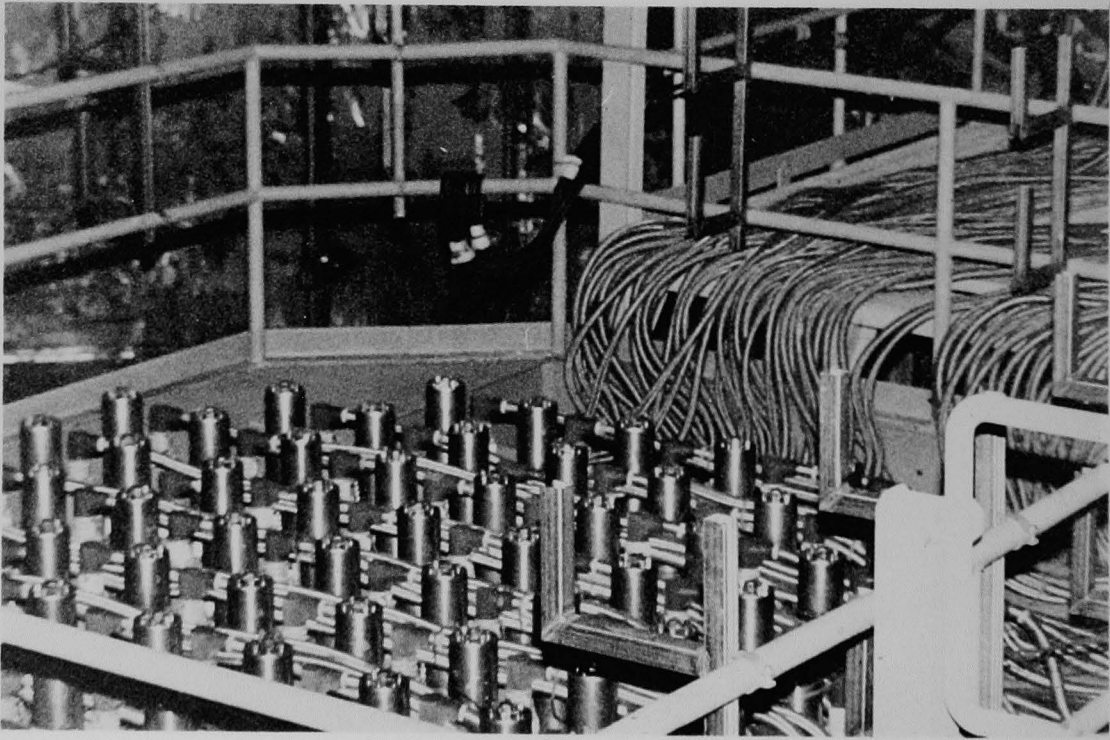

Figure 248 (5B). Close-up of the CRDM platform above the reactor vessel.

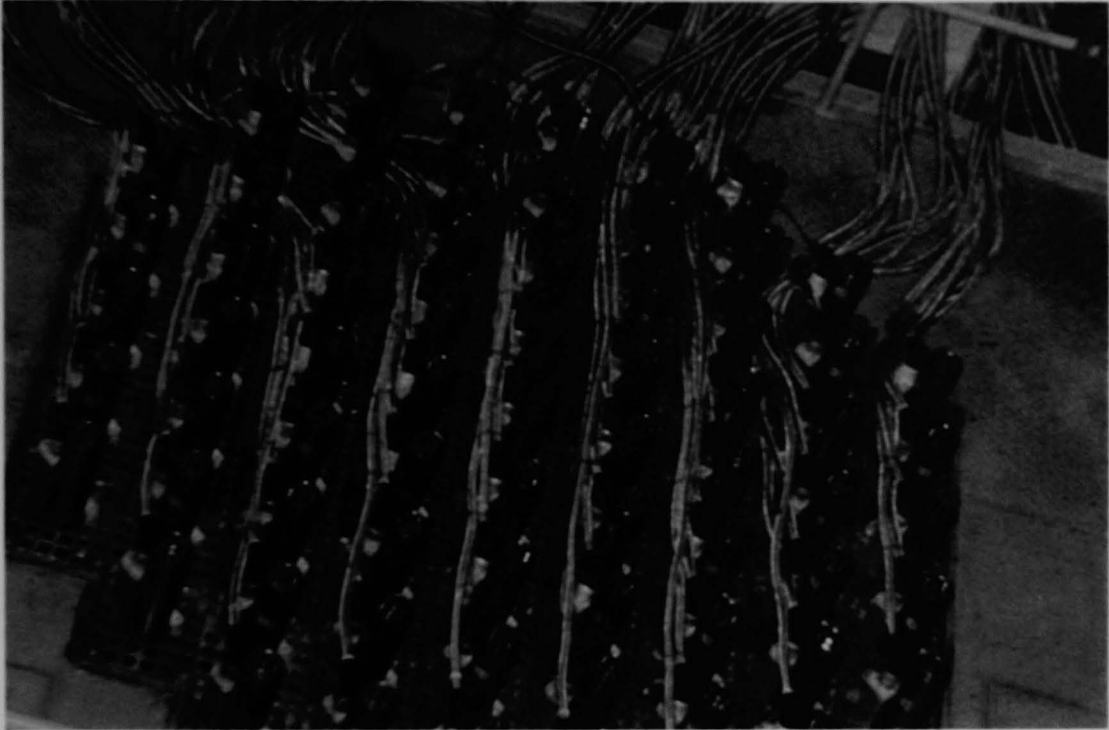

Figure 249 (4B). Close-up of the CRDM platform from overhead.



Figure 250 (6A). View south along CRDM cable trays; CRDM cables protruding in background.



Figure 251 (6A). Close view of CRDM cable trays; hand rail to auxiliary fuel handling bridge right.



Figure 252 (5C). North end of fuel pool; main fuel handling bridge left, up ender and internals storage stand left center in deep portion of the pool.

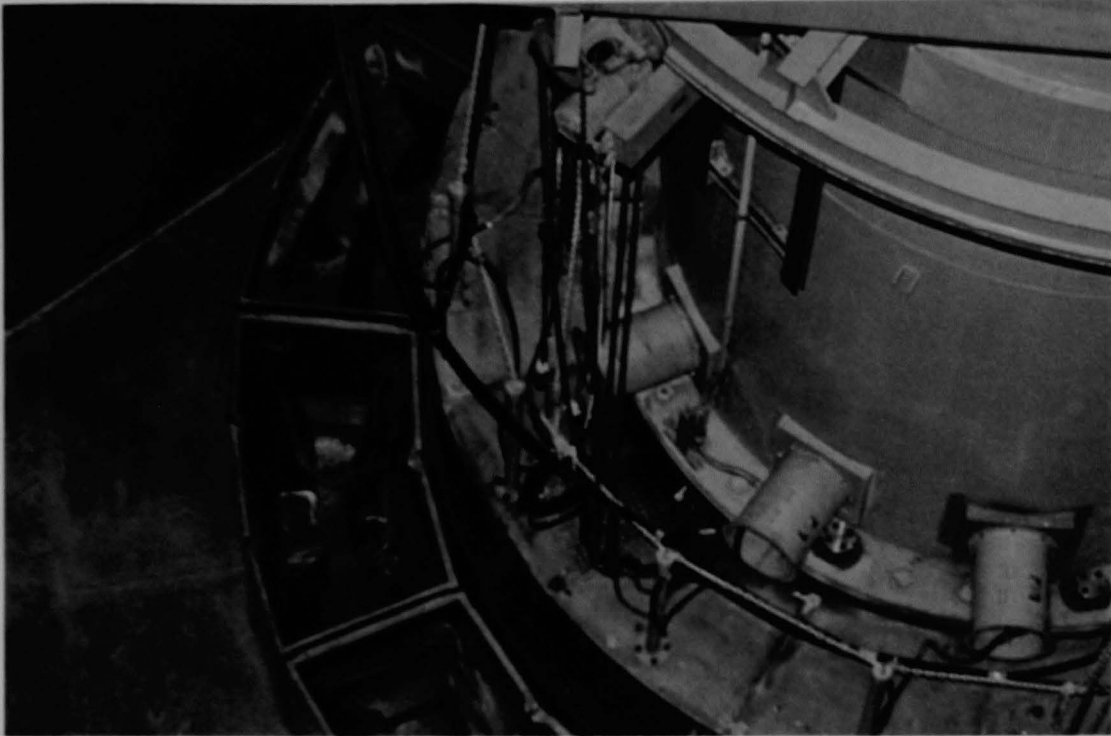

Figure 253 (4B). The reactor head from above (the neutron shield tanks appear to be dry).

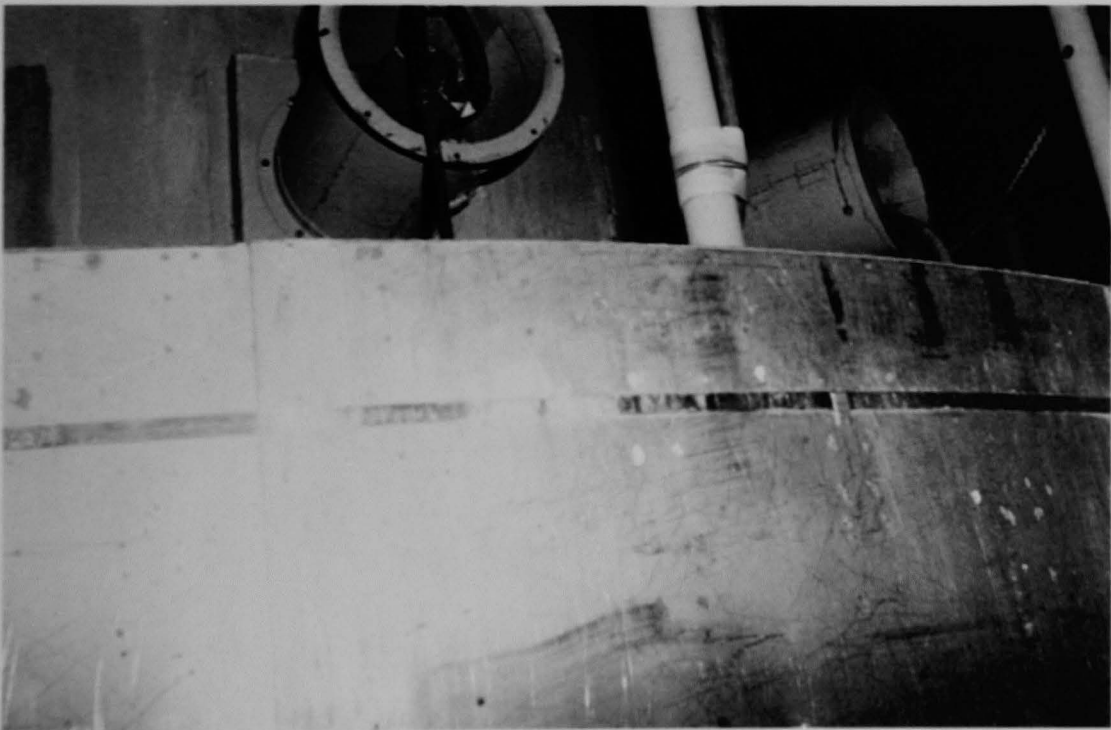

Figure 254 (5A). Fan housings on the reactor head.



Figure 255 (5A). Base of the reactor vessel with neutron shield tanks.



Figure 256 (5A). View inside of neutron shield tank (technician on shield tank to gain access to the north side of the reactor vessel).



Figure 257 (5A). View underneath a neutron shield tank.



Figure 258 (5A). Second view underneath a neutron shield tank.



Figure 259 (5A). Close-up view under a neutron shield tank.

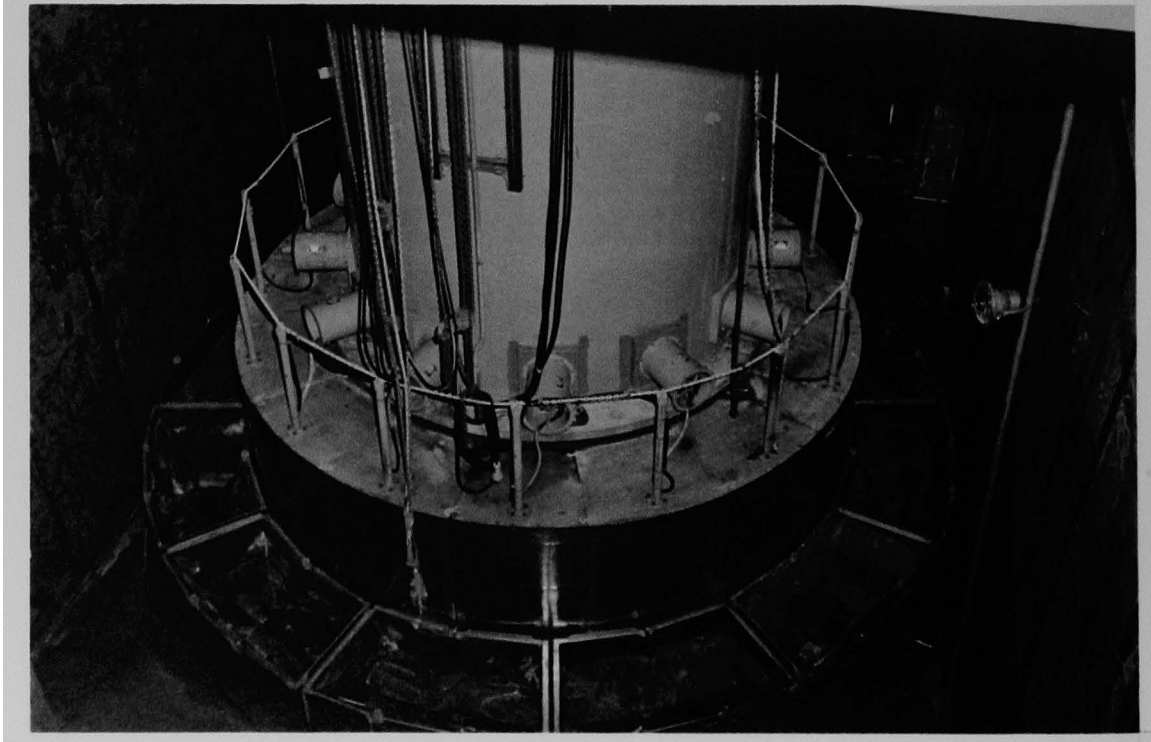

Figure 260 (2A). Reactor vessel head.



Figure 261 (5A). Close-up of a portion of a neutron shield tank (see Figure 260 foreground right center).



Figure 262 (2A). Reactor vessel head, fuel handling girder above

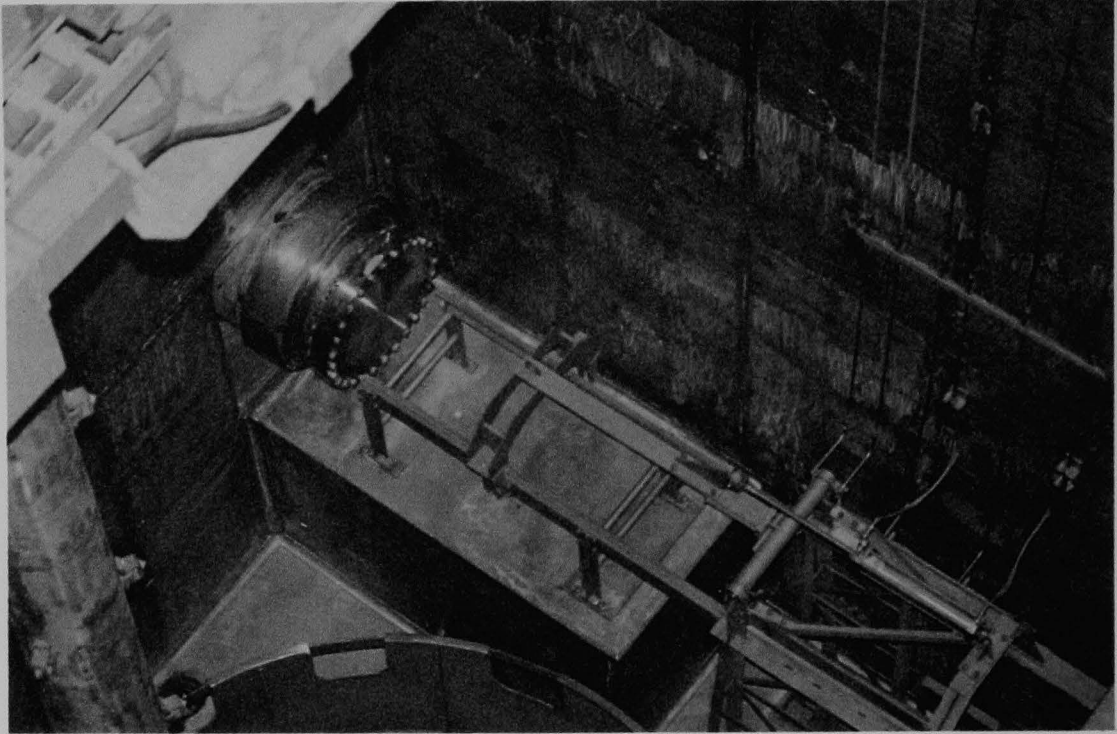

Figure 263 (4B). Deep (north) end of the fuel pool; main fuel handling bridge left, fuel transfer tube left center.

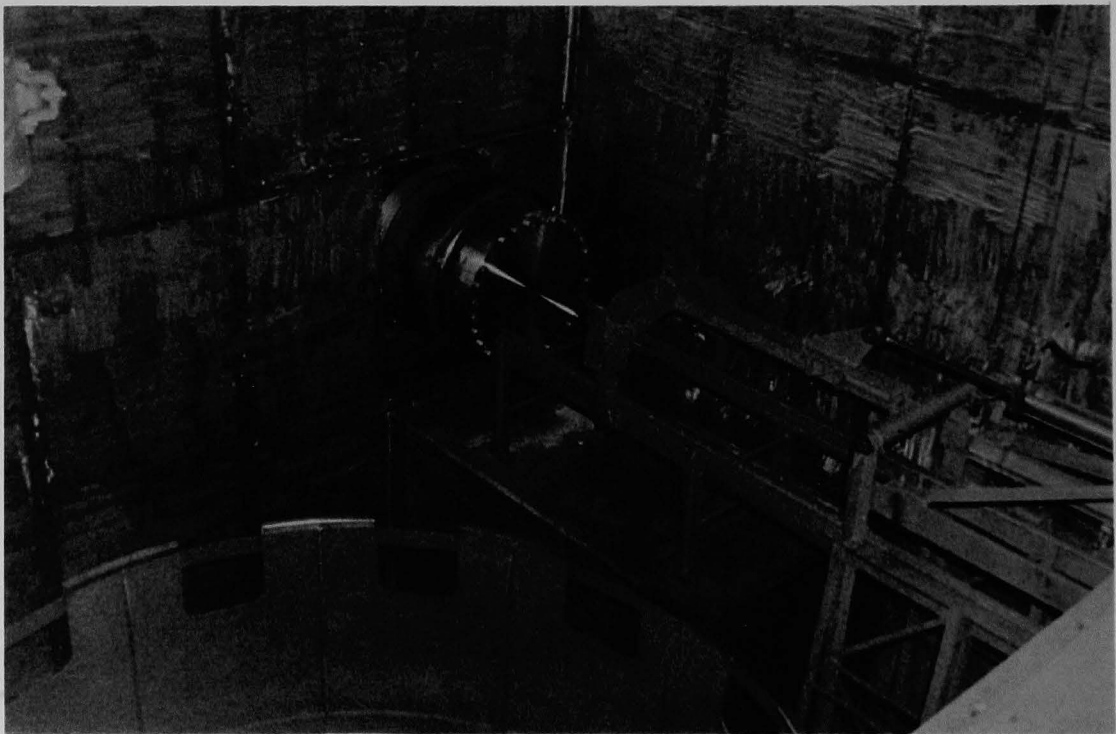

Figure 264 (5A). Deep (north) end of the fuel pool, second view.



Figure 265 (5C). View down southeast into the fuel pool (photograph taken to document boron crystal accumulation); reactor vessel, neutron shield tanks, and boots of HP technician background.

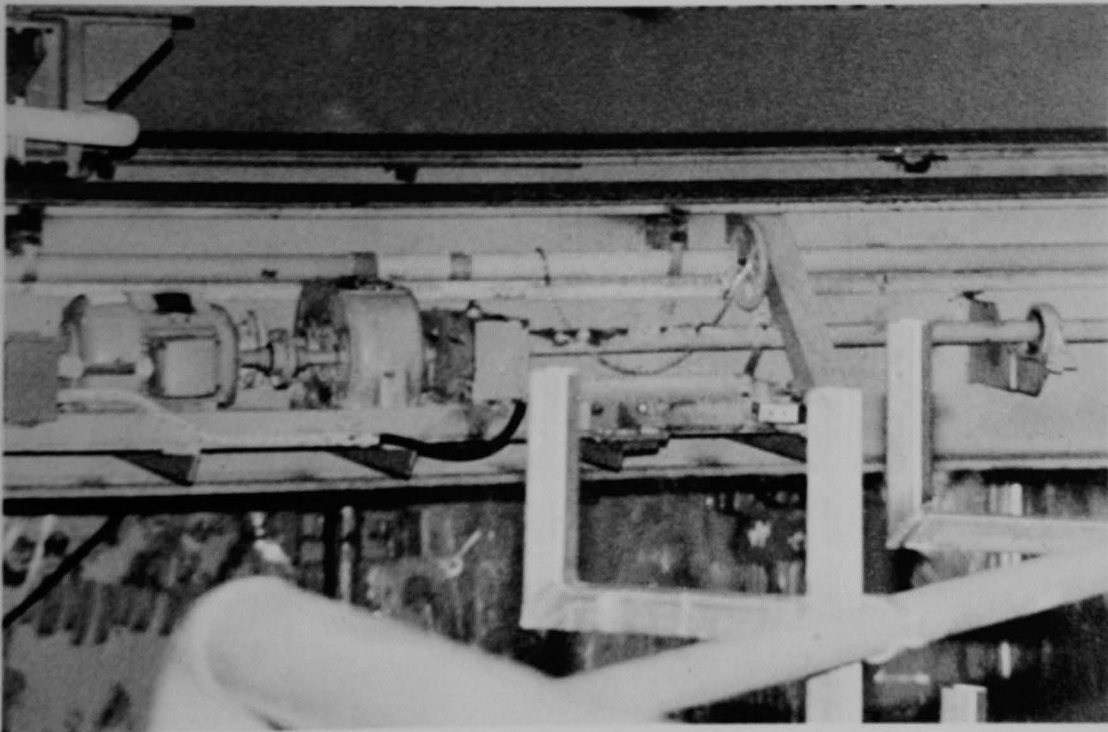

Figure 266 (5B). Motor, gear box, and drive shaft on south side of main fuel handling bridge.

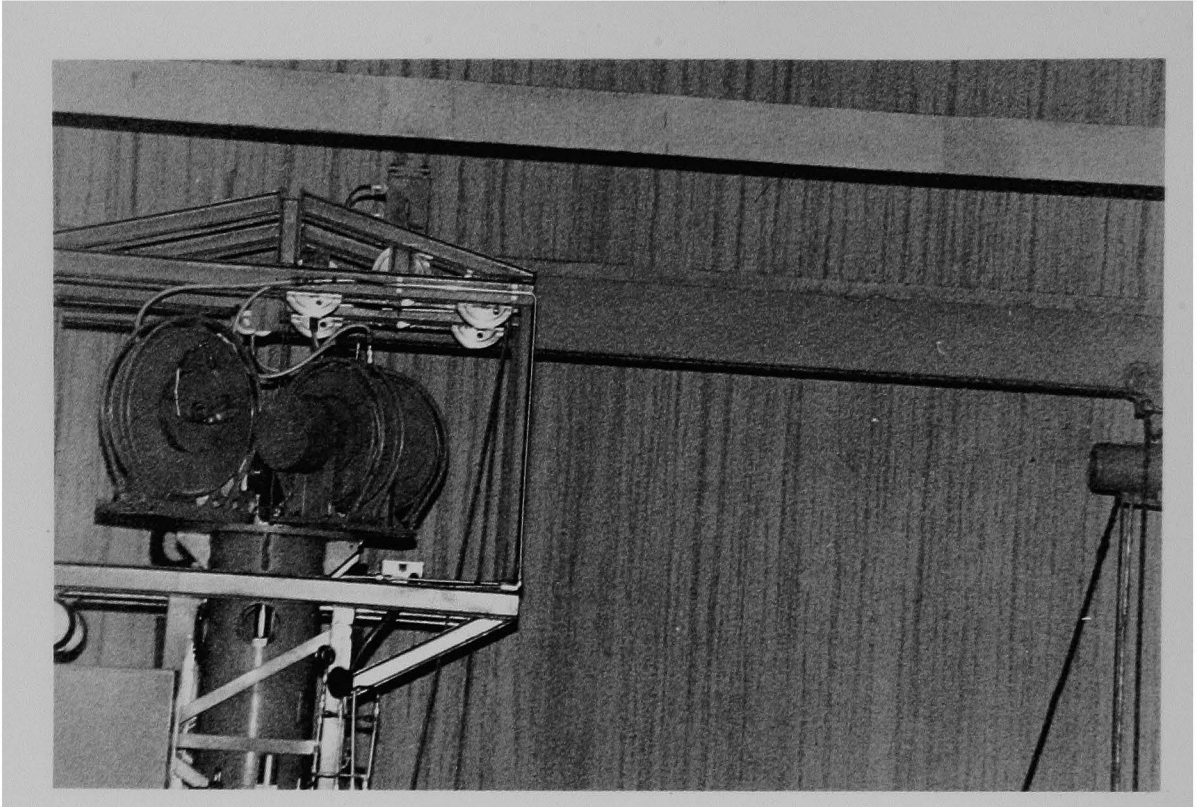

Figure 267 (5B). Upper portion of the main fuel handling bridge.

CRANE ELEVATIONS



Figure 268 (4B). Access platform to the polar crane; containment spray lines left.



Figure 269 (5B). Close-up of the access platform to the polar crane.

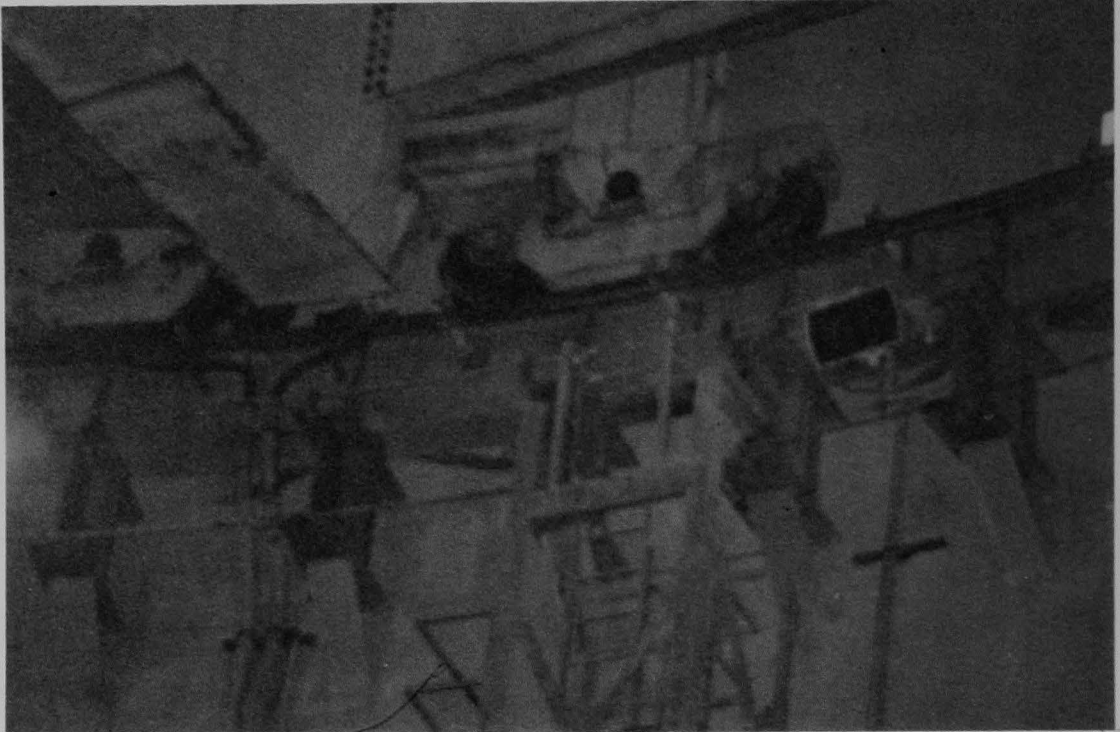

Figure 270 (4B). East side of polar crane near access platform.



Figure 271 (6A). Ventilation duct on the containment wall, southwest quadrant.

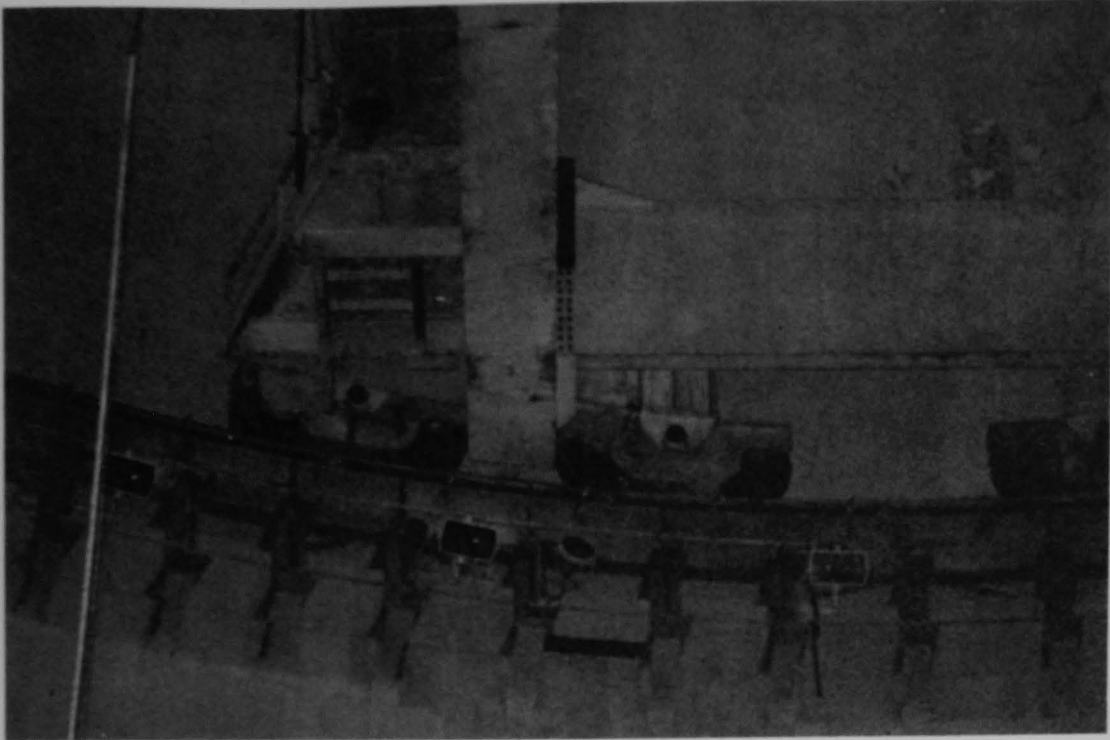

Figure 272 (4B). End of the polar crane opposite the operator's cab, northwest quadrant.

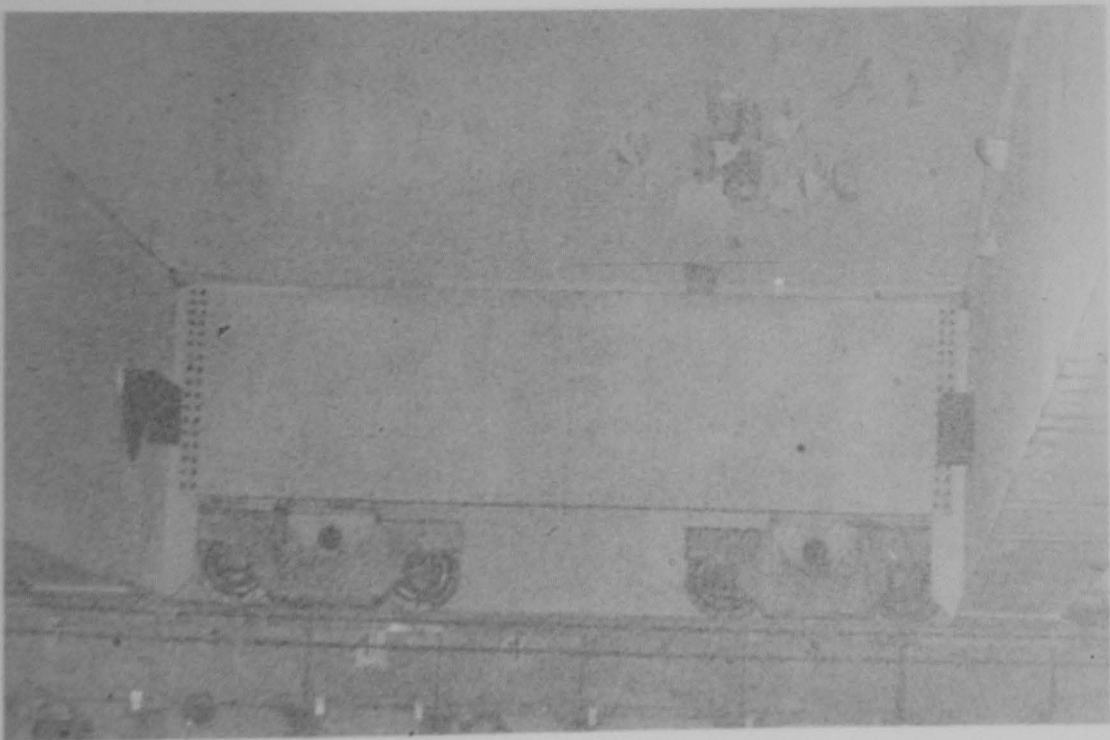

Figure 273 (5B). End of the polar crane opposite the operator's cab, northwest quadrant, second view.



Figure 274 (5B). Trolley and one of its wheels.

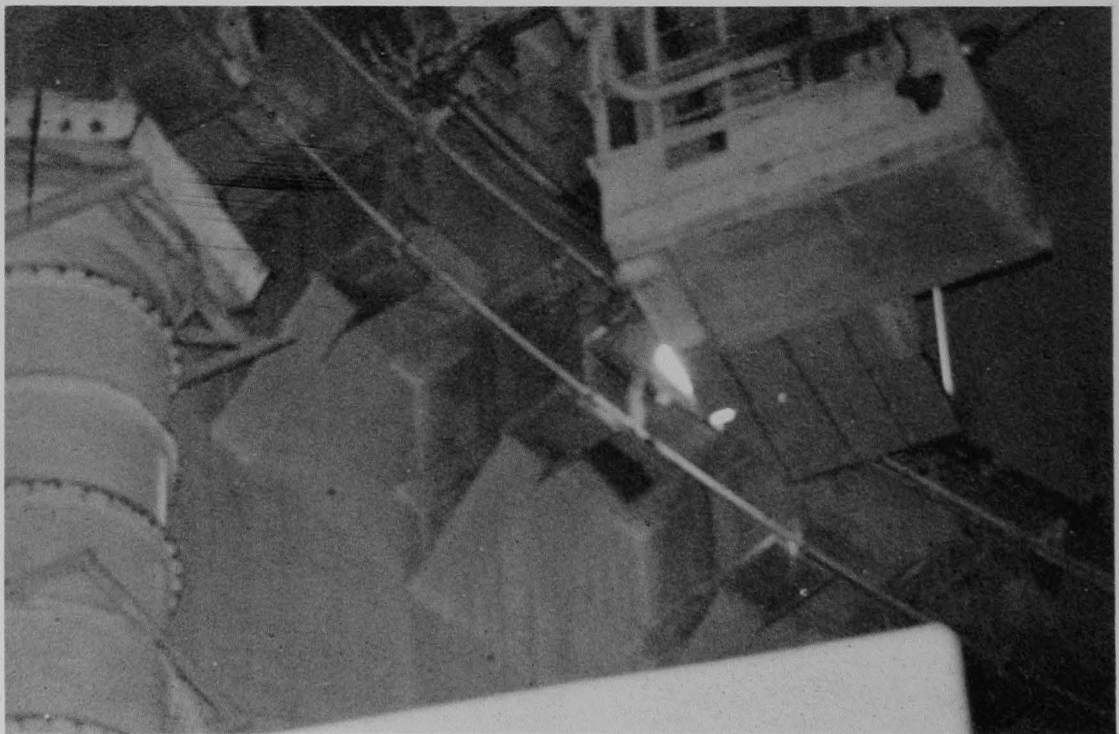

Figure 275 (5B). Polar crane cab and upper portion of ventilation duct left.



Figure 276 (5B). Top of ventilation duct near the enclosed stairwell.

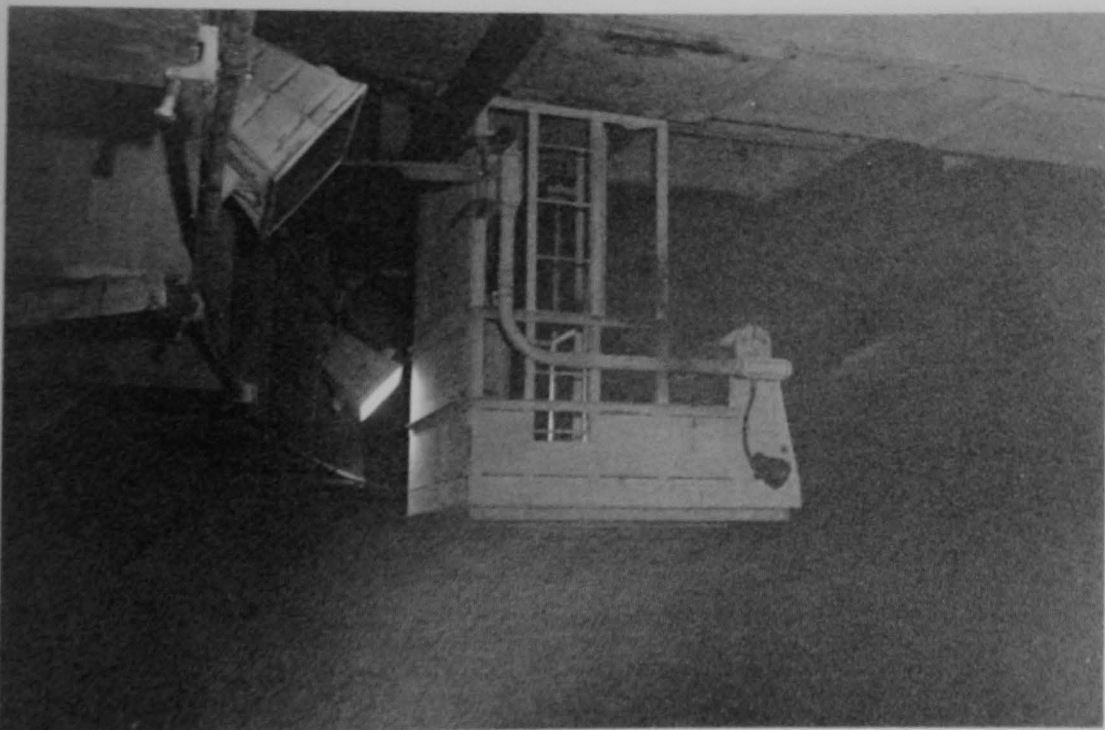

Figure 277 (5A). Polar crane cab (cf. Figure 275).

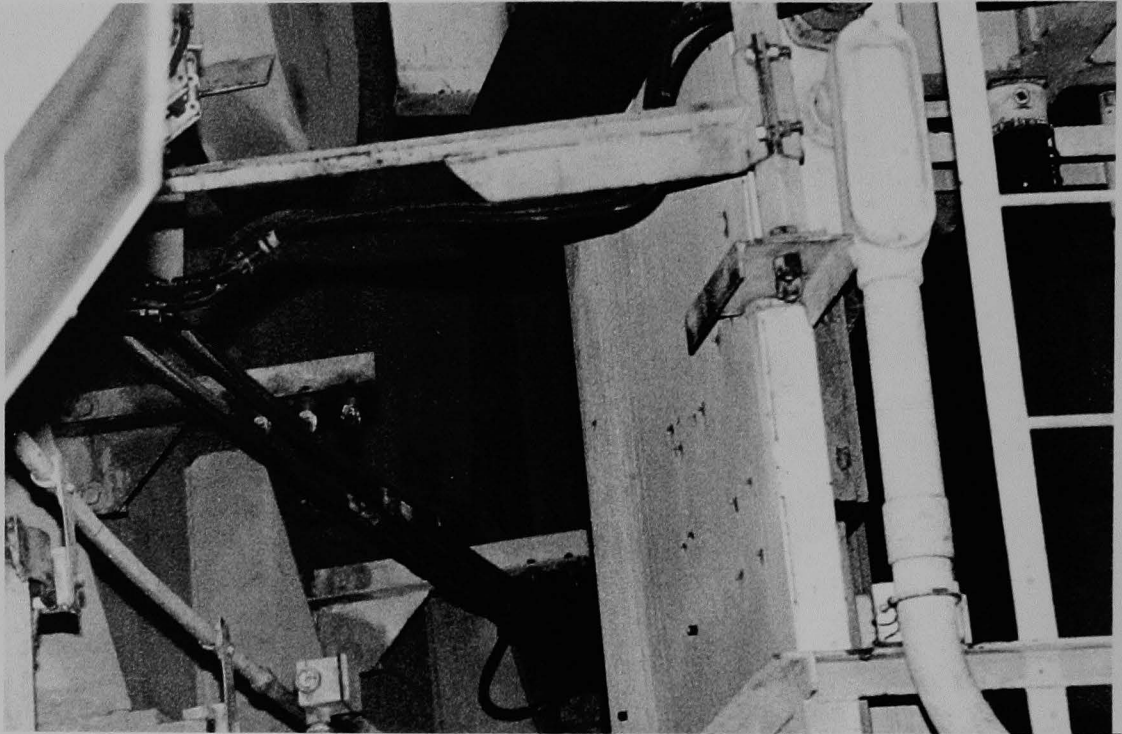

Figure 278 (5B). Polar crane power buss bars (note that one is missing, having dropped to operating deck).



Figure 279 (5B). Closer view of the power buss bars (cf. Figure 278).

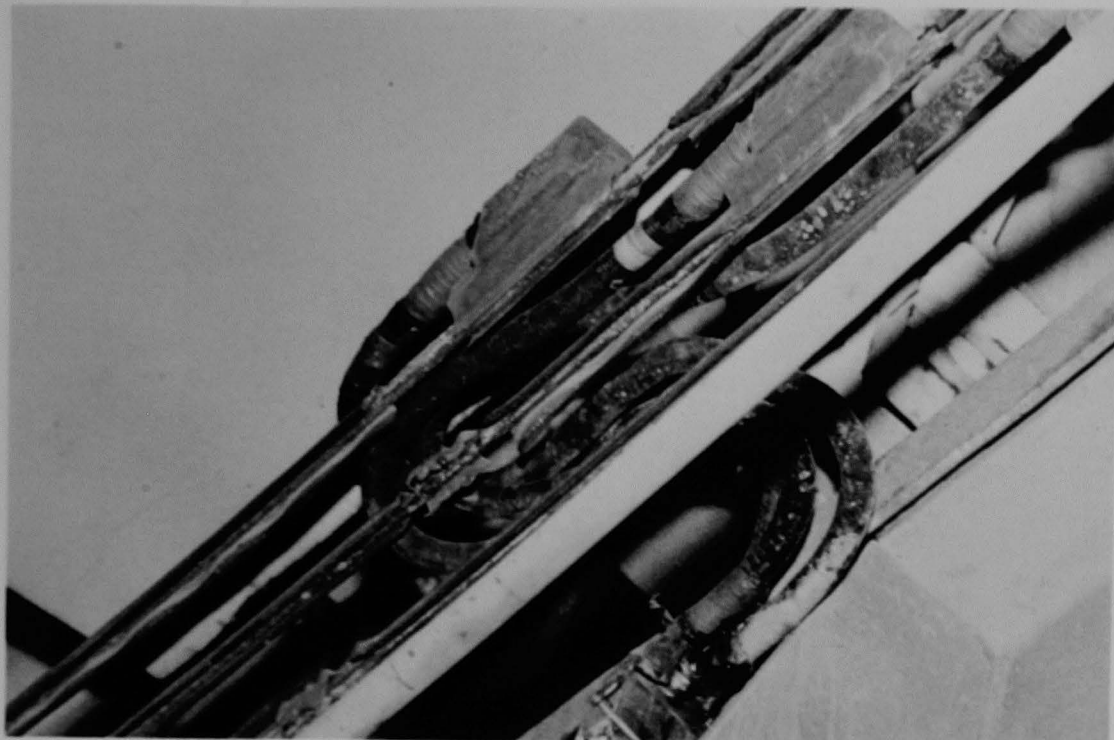

Figure 280 (5B). Close-up of power and controller buss bars for the polar crane.

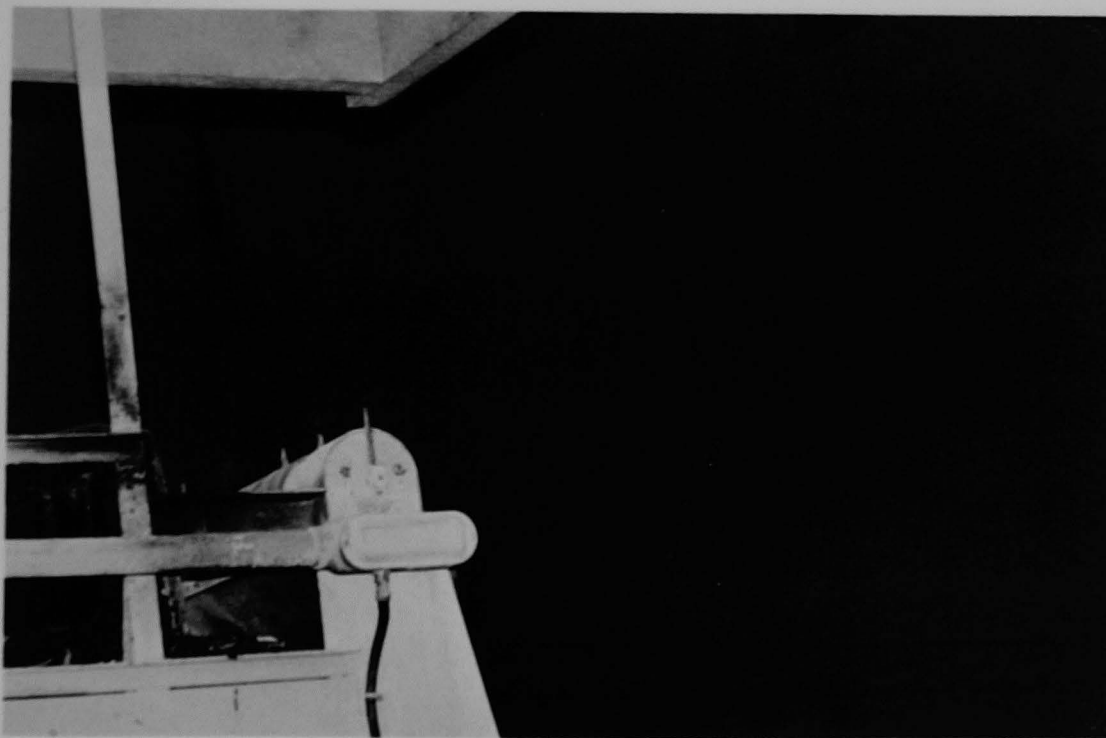

Figure 281 (5B). Control levers of the polar crane cab.



Figure 282 (5B). Control levers of the polar crane cab, second view.

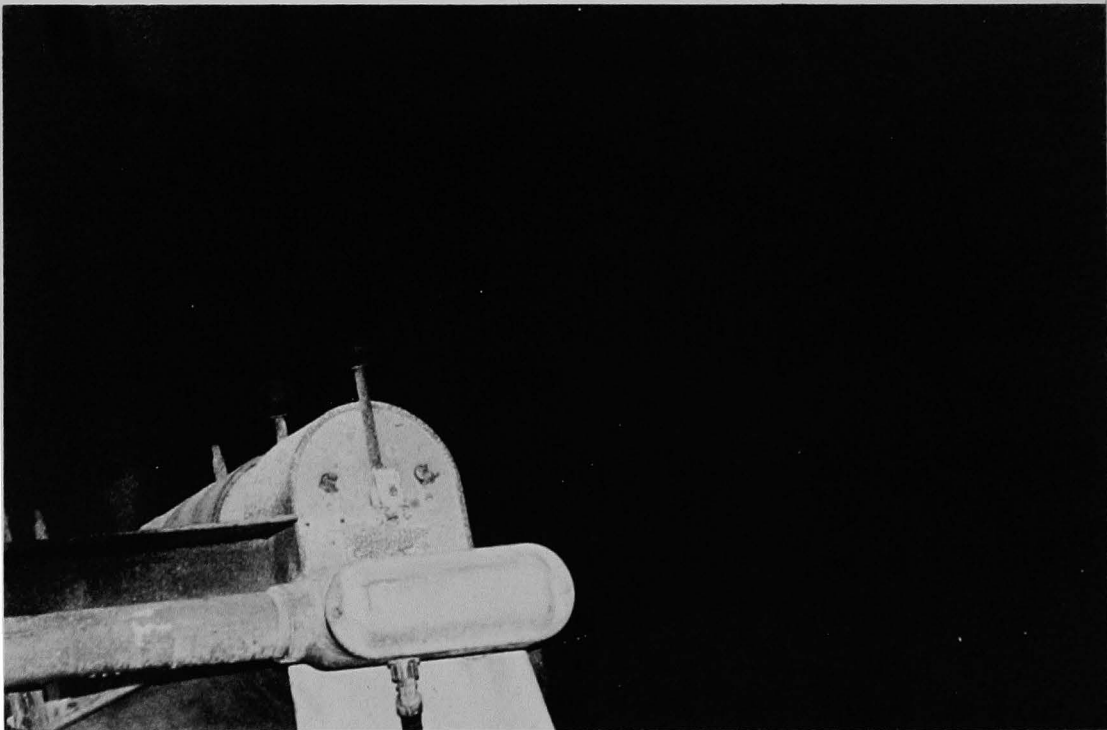

Figure 283 (5B). Close-up of levers of the polar crane cab.

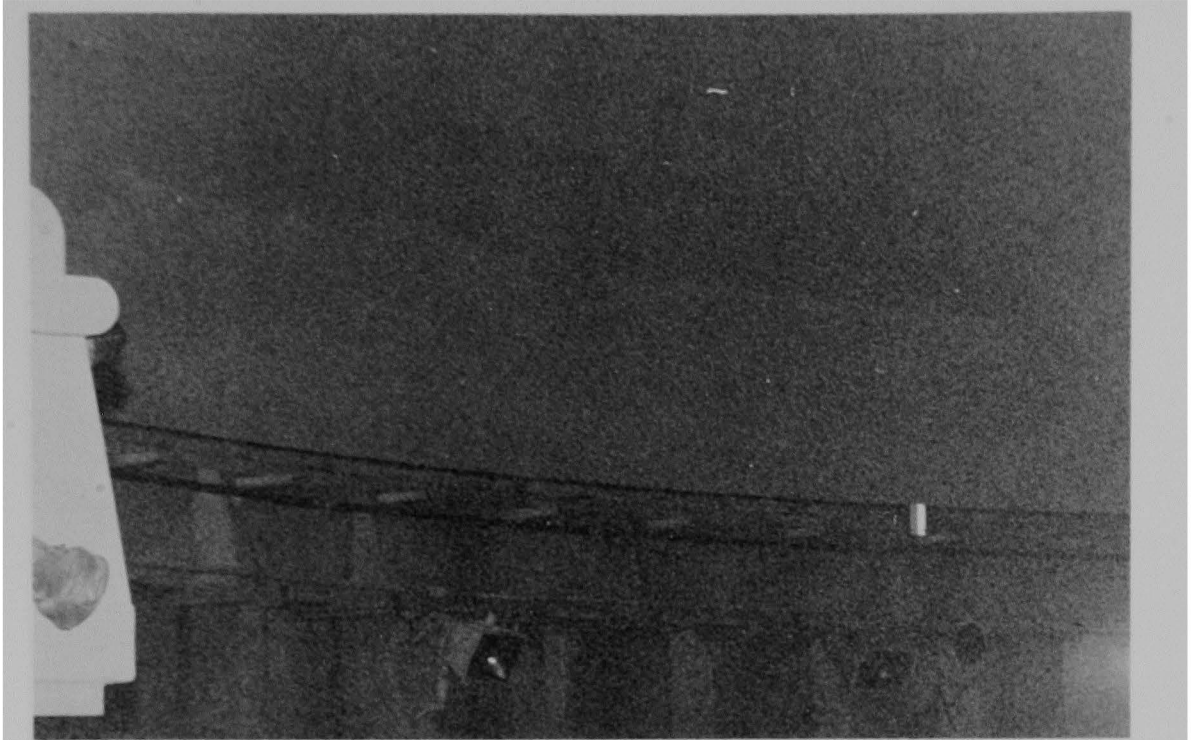

Figure 284 (5B). Lights around dome of the containment building; polar crane cab left.

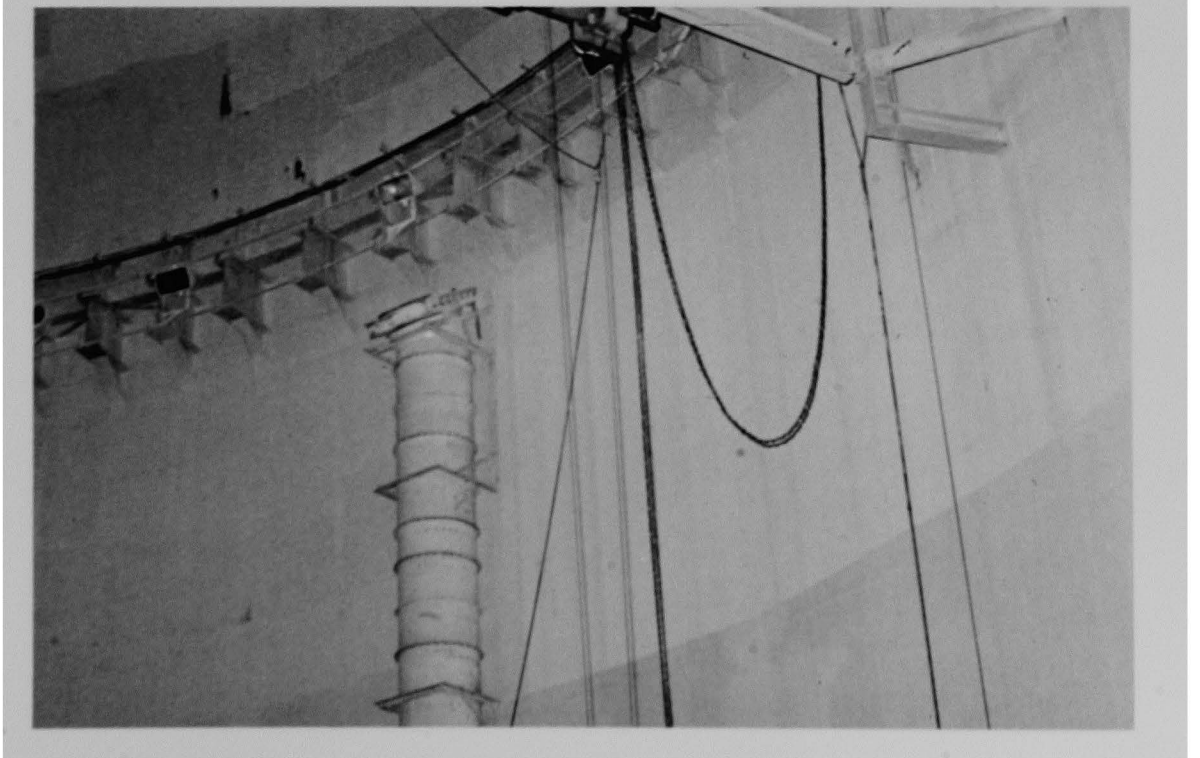

Figure 285 (4). Top of the ventilation duct; job crane right. (Note that not all lights circling the containment are on.)



Figure 286 (2B). Jib crane and support box, southwest quadrant.



Figure 287 (6A). Jib crane; D-ring A lower right.



Figure 288 (5B). Jib crane control pendant, and lifting hook.



Figure 289 (4B). Girder A of the polar crane.



Figure 290 (5A). Girder B of the polar crane, with hook and cables.

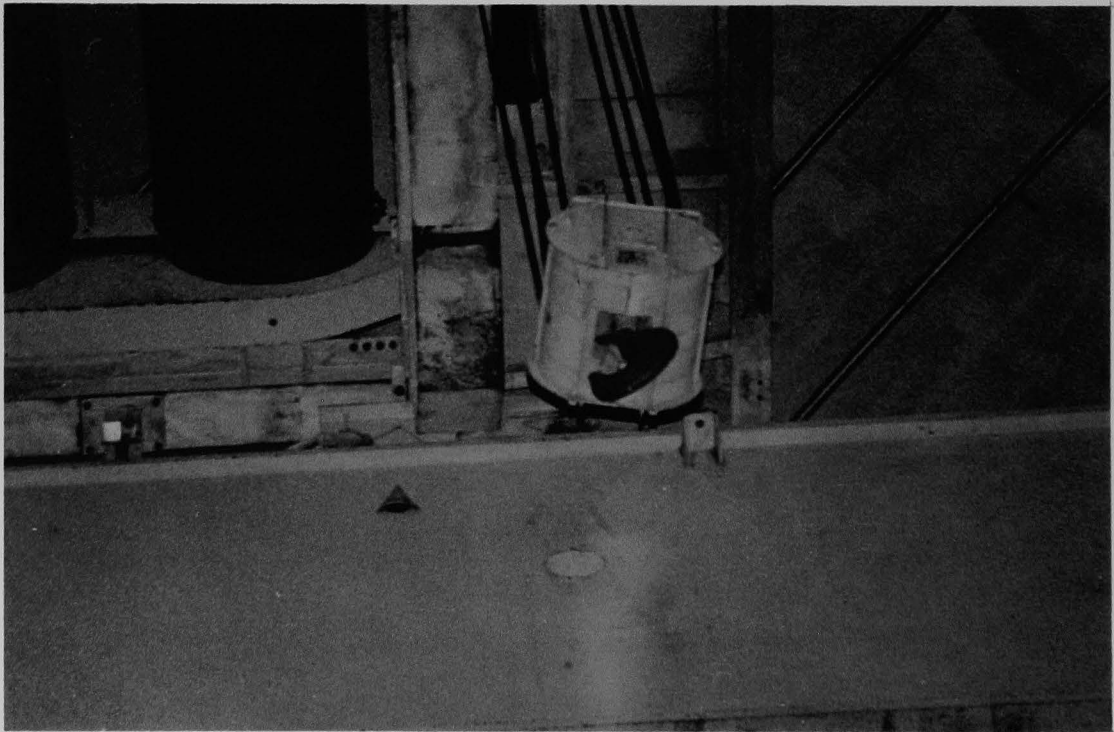

Figure 291 (4B). Auxiliary hook of the polar crane.



Figure 292 (4B). Main hook of the polar crane.



Figure 293 (5B). Main hook of the polar crane, second view.



Figure 294 (4B). Main hook of the polar crane, third view.

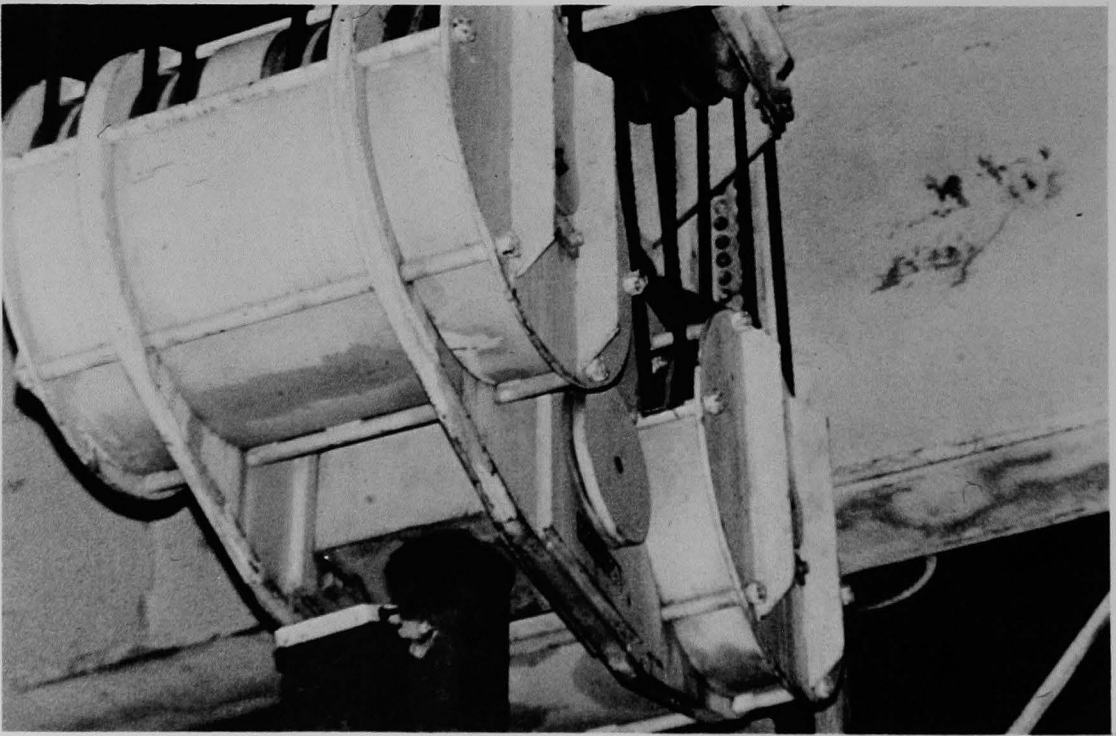

Figure 295 (5B). Main hook of the polar crane, fourth view.



Figure 296 (5B). Main hook of the polar crane, fifth view.

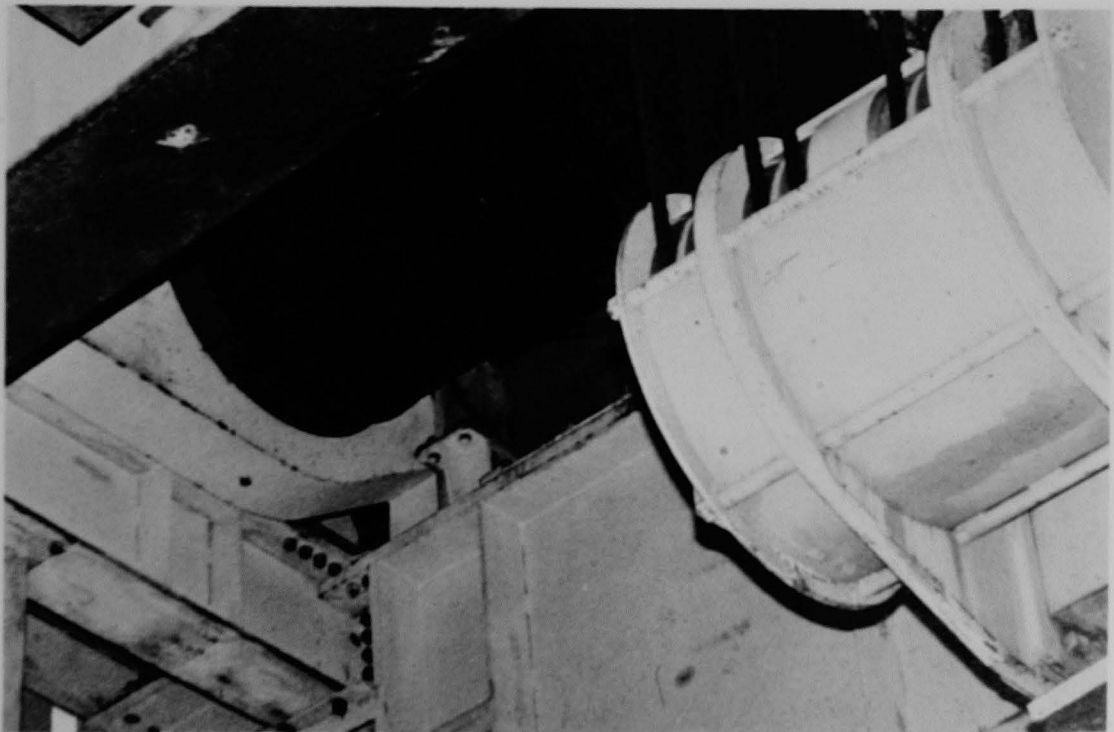

Figure 297 (5B). Cable drum and the main block of the trolley on the polar crane.



Figure 298 (5B). Cable drum and the main block of the trolley on the polar crane, second view.



Figure 299 (5B). Cable drum on right side of the trolley over girder B (cf. Figures 297 and 298).



Figure 300 (5B). Close-up of cables for the main hook.

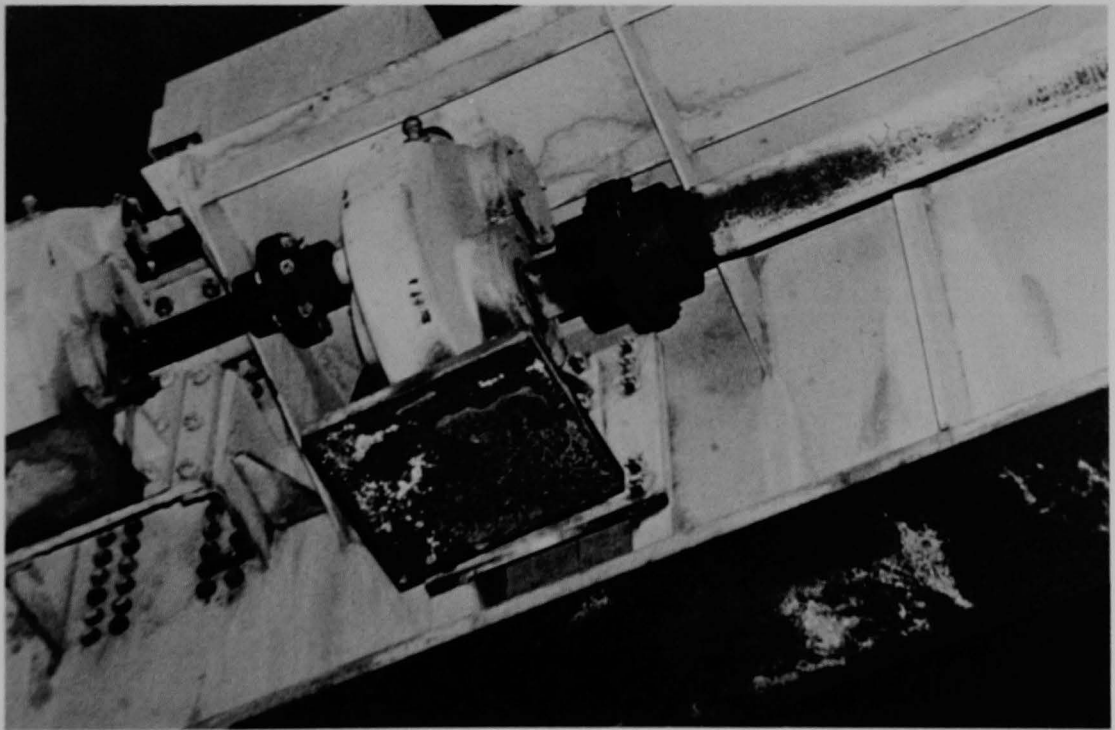

Figure 301 (5B). Gear housings and drive shafts on the trolley of the polar crane.



Figure 302 (4B). Containment dome north of the enclosed stairwell.

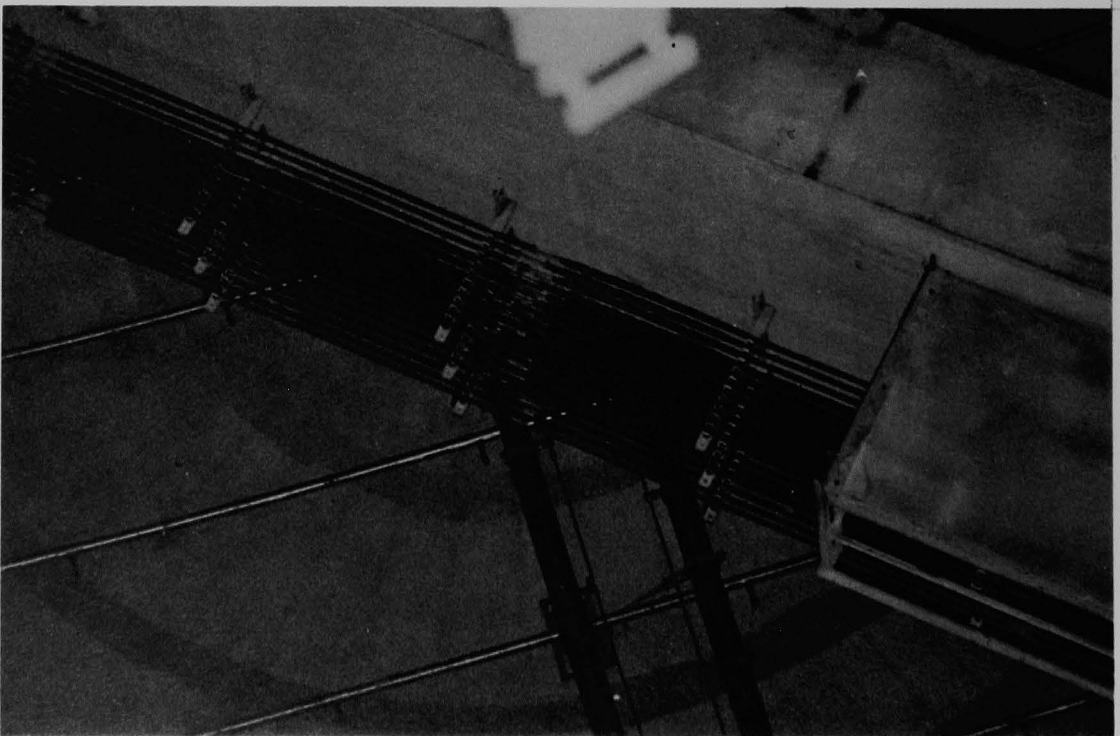

Figure 303 (4B). Trolley power and controller buss bars along side of girder B.



Figure 304 (4B). Trolley power and controller buss bars along side of girder B (out of focus), second view.

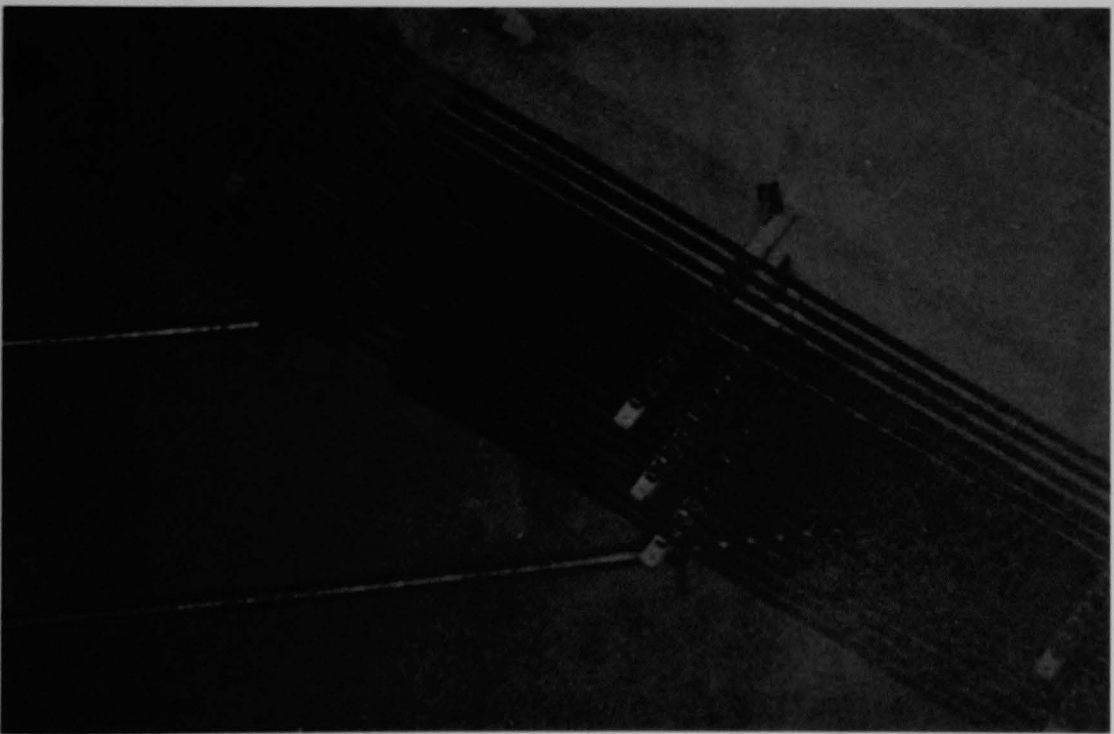

Figure 305 (4B). Trolley power and controller buss bars along side of girder B, third view.



Figure 306 (5B). Trolley power and controller buss bars, view from the midpoint of the polar crane access ladder.

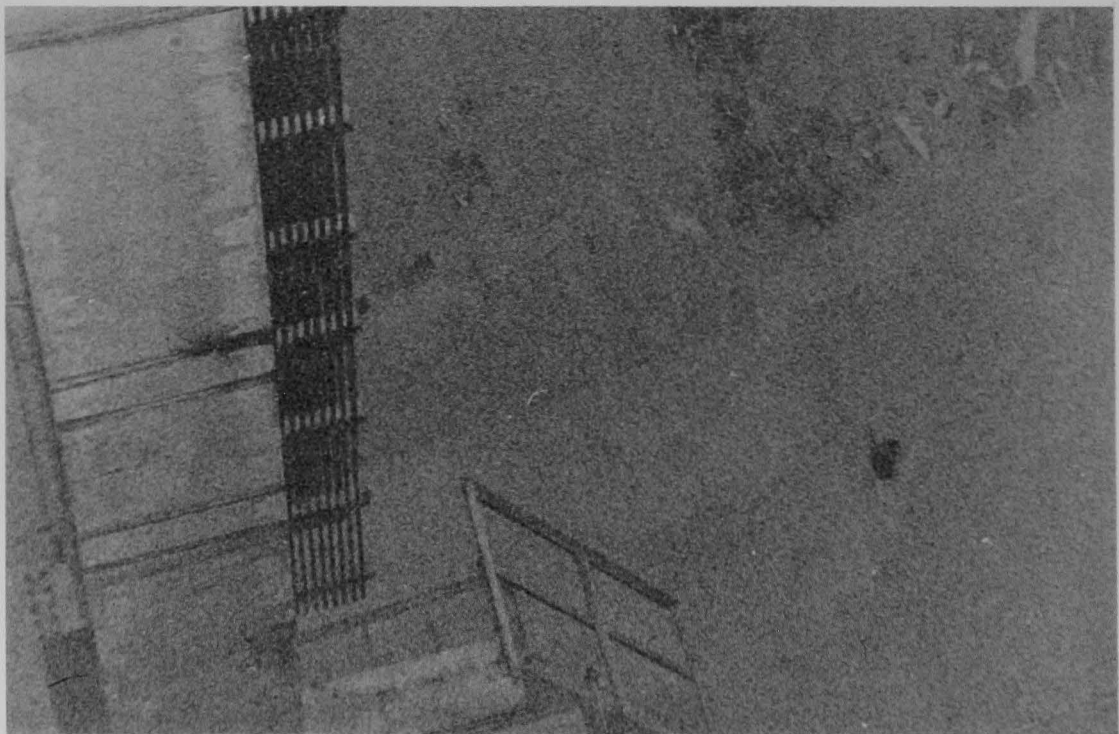

Figure 307 (5B). Northwest portion of girder B, showing trolley power and controller buss bars.

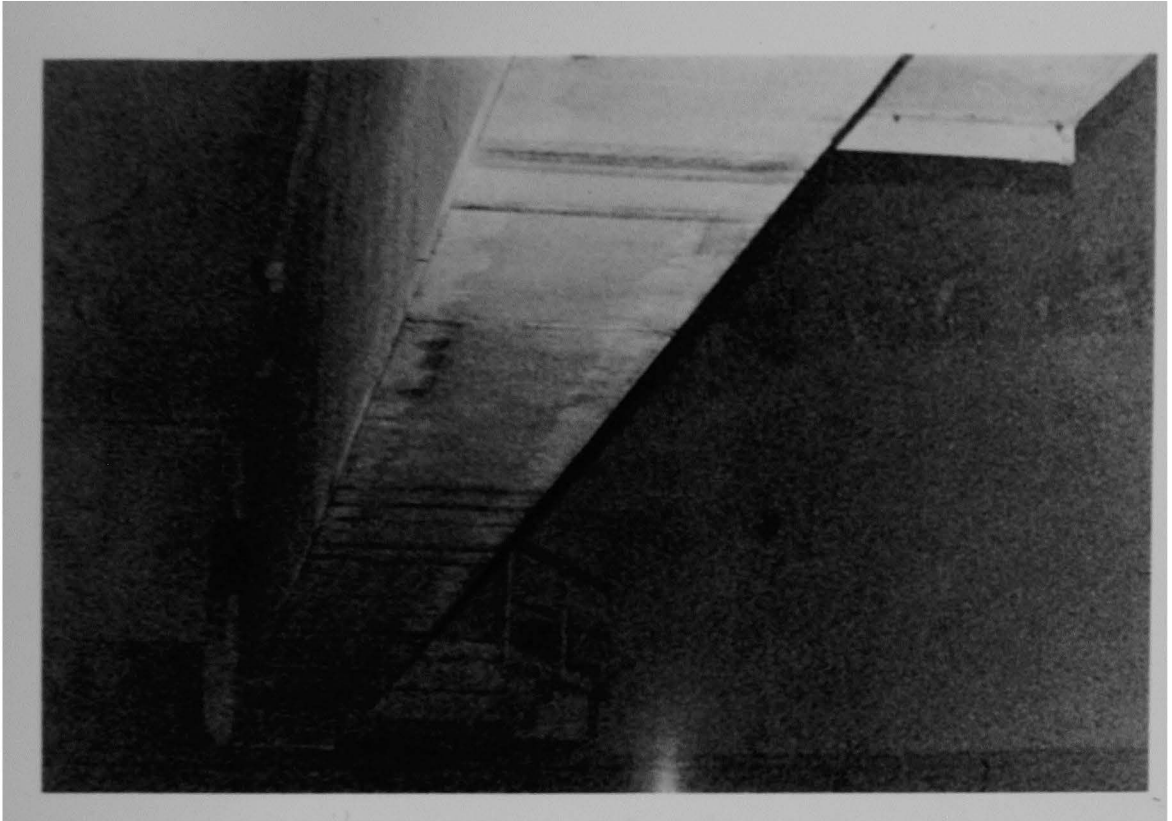

Figure 308 (5B). View northwest across containment down the length of girder B of the polar crane.

3 4444 00005381 9

f

